

MECHANICS BODY PAL Pro 39

Mechanics Bodies, Service Cranes & Compressors
built for the modern work truck.

LIFETIME EXCELLENCE



HIGHLIGHTS

Extending the PALFINGER range of mechanics bodies, PAL Pro 39 is our new light weight generation available in 9' and 11' standard configurations. In this development, we discovered new ways to reduce weight and become the lightest steel construction crane body in the industry. With new light-weight aluminum doors, PAL Pro 39 offers you more usable payload, combined with a stronger and lighter crane. Plus, more standard options are available to meet your service truck needs including headache rack, accessory mounting options, additional tail shelf options and more. PAL Pro 39 is manufactured with 12-gauge all A-60 galvanneal steel construction, a hybrid torsion box that eliminates frame and side pack deflection and the best rust protection in the industry.

NON-MARRING BOOM REST

Optional fixed or adjustable non-marring boom support E-coated black.



INTERIOR COMPARTMENT COATING FOR GREATER PROTECTION

A two-part, water based compound lines every interior compartment as standard to prevent rust from forming in the compartments, while providing superior protection against tools, chains and parts that can cause damage to the compartment interiors.

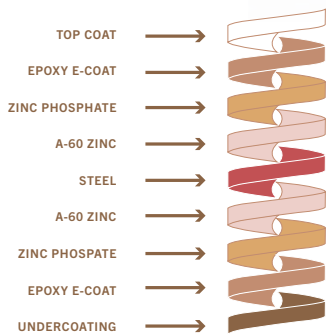

E-COAT CORROSION PROTECTION

PALFINGER'S 12 step electrophoretic deposition dip process cleans the body & applies primer to the metal surfaces, ensuring complete coverage & automotive grade corrosion protection.

ALUMINUM DOORS & TRAYS LIGHT-WEIGHT & CORROSION RESISTANT

PALFINGER'S unique automotive adhesive bonded two piece doors, hinges, and compartment divider trays are now all in aluminum. This means increased payload capacity.

RAISED COMPARTMENT REINFORCEMENTS STRUCTURAL INTEGRITY

Every raised compartment comes with our engineered structural gussets to prevent against body cracking in the door corners.



With the best equipment for the job, add a competitive edge to your business in a range of industries. Our mechanics trucks are a reliable partner in: Construction, Roadway, Railway, Agriculture, Oil & Gas, Mining, Utilities and Municipalities.

Add one of our light weight, long reach, and increased lifting capacity cranes, and our lightest in the industry rotary screw hydraulic compressors and you have the strongest, lightest 39,000 ft lbs capacity crane package.

APPLICABLE CRANE MODELS

- PSC 3216
- PSC 4016
- PSC 4025
- PSC 5025
- PSC 6025

APPLICABLE COMPRESSORS

- PRC 45V

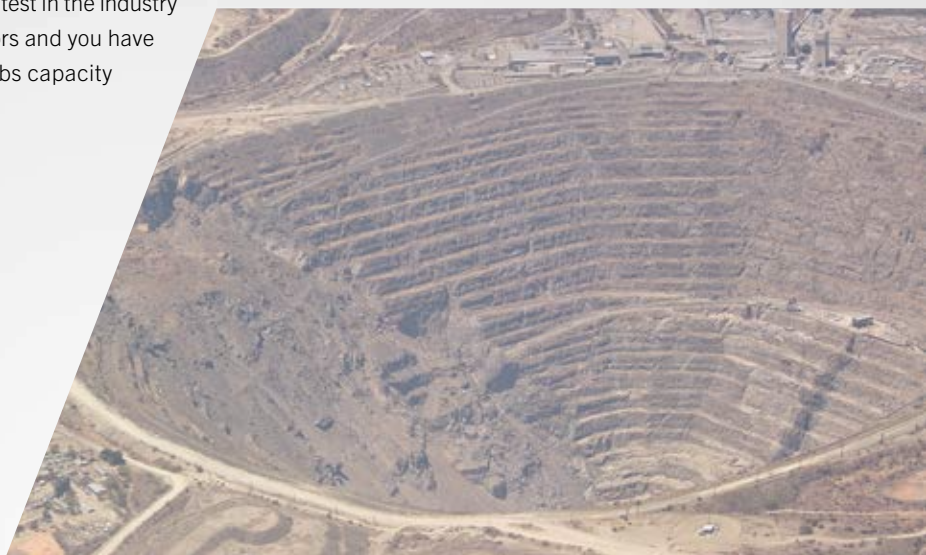



**HYBRID TORSION BOX
BUILT FOR CRANES**

Designed from the start for crane applications and utilizing 12ga A-60 galvanneal steel, the hybrid torsion box eliminates truck frame twist and side pack deflection.

**STRUCTURAL CROSS-MEMBERS
PAYLOAD SUPPORT**

Tubular 3" x 5" structural steel cross-members interlace the torsion box to support compartment loads.

**OUTRIGGER HOUSING
INTEGRATED LIFTING SUPPORT**

Integrated outrigger tube reduces stress on chassis frame by transferring the crane load directly to the ground.

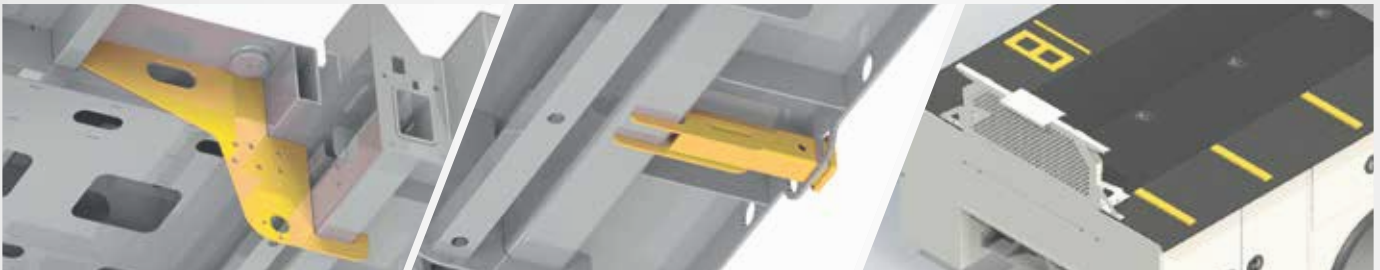

**REAR SHEAR PLATE BODY MOUNTS
SECURE AND SUPPORTIVE MOUNTING**

Steel plates prevent lateral body shift on chassis, providing additional support for crane loads.

**INTEGRATED HITCH RECEIVER
CLASS 5 RECEIVER**

2" I.D. receiver tube, attached directly to body substructure.

**THREADED WELDMENT OPTIONS
TO PROTECT YOUR BODY**

Boom Rest, Welder, Compressor, EnPak, Air-n-Arc and AirPak mounts are available from the factory to eliminate the need to drill holes in the body.

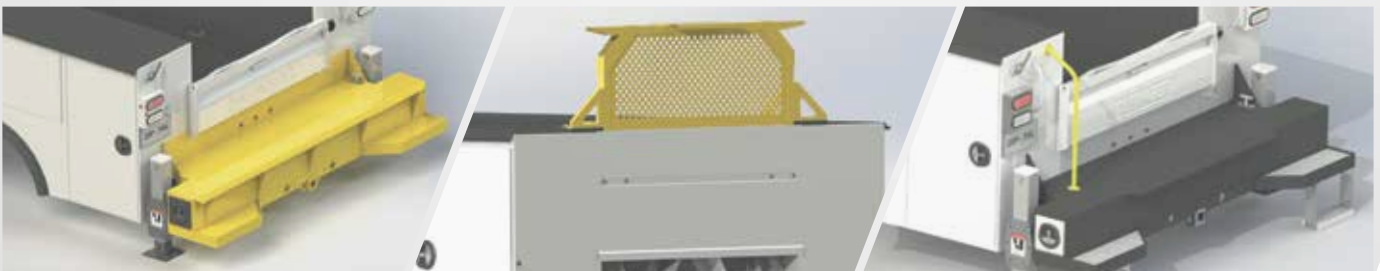

**WORK BENCH
BUILT FOR YOUR HARD WORK**

A true mechanics workbench, featuring 12" or 21" work bench bumpers, receiver hitch, 1/4" steel top plate and thru compartment for additional storage. Pictured 21" pipe trough.

**HEADACHE RACK
SAVES COSTLY REPAIRS**

This light bar bracket with a punched screen prevents cargo area contents from making contact with the rear window of the cab - saving you from costly rear window repairs & cleanup.

**BOLT ON HANDRAIL OPTION
FOR ADDED SAFETY**

Ergonomically designed handrail option, with a stable surface to grip, for your added security against tripping or slipping hazards.

TECHNICAL SPECIFICATIONS

39-9

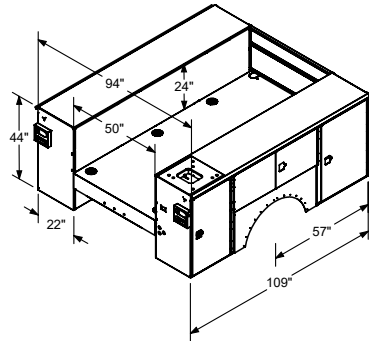

9' standard configuration
 44" tall compartment heights
 14" tall one handed tailgate
 Treadplate compartment top overlays

39-9CS

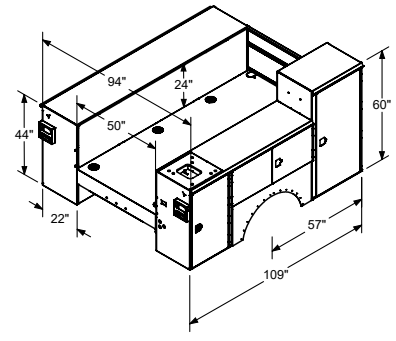

9' standard configuration
 44" tall compartment heights
 CS front compartment raised to 60"
 14" tall one handed tailgate
 Treadplate compartment top overlays
 Reinforced raised compartment

39-9SSCS

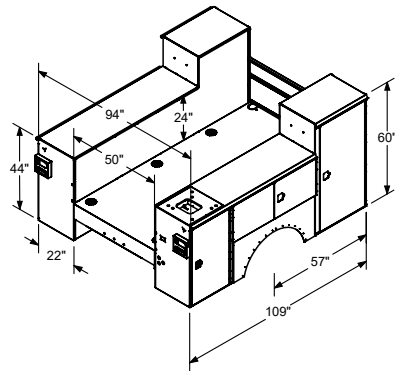

9' standard configuration
 44" tall compartment heights
 SS & CS front compartment raised to 60"
 14" tall one handed tailgate
 Treadplate compartment top overlays
 Reinforced raised compartments

39-11

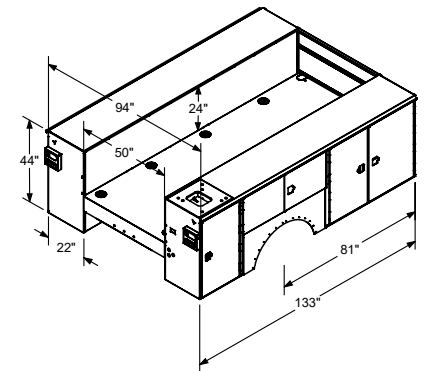

11' standard configuration
 44" tall compartment heights
 14" tall one handed tailgate
 Treadplate compartment top overlays

39-11CS

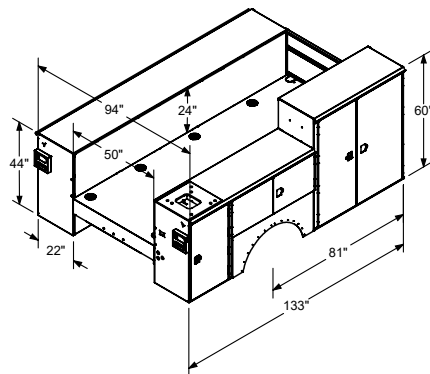

11' standard configuration
 44" tall compartment heights
 CS front compartment raised to 60"
 14" tall one handed tailgate
 Treadplate compartment top overlays
 Reinforced raised compartment

39-11SSCS

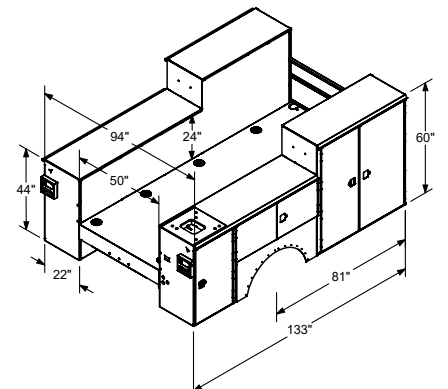

11' standard configuration
 44" tall compartment heights
 SS & CS front compartment raised to 60"
 14" tall one handed tailgate
 Treadplate compartment top overlays
 Reinforced raised compartments

SERVICE CRANE

PRODUCT RANGE

TECHNICAL SPECIFICATIONS

MODEL	CAPACITY	RATED LIFTING MOMENT	MAX LIFTING MOMENT	BOOM EXTENSIONS	POWER OUTREACH	WINCH SPEED	STANDARD WEIGHT	CHASSIS SPECIFICATION
PSC 3216 E	4,000 lbs. (1814 kg)	12,500 ft. lbs. (17 kNm (1.7 mt))	14,560 ft. lbs. (19.6 kNm (2.0 mt))	1 Hydraulic + 1 Manual (2 Hydraulic Option)	11.4 ft. (16 ft.) 3.5 m (4.9 m)	18.0 ft./min (5.5 m/min)	650 lbs. (295 kg)	Class 3
PSC 3216 H	4,000 lbs. (1814 kg)	12,500 ft. lbs. (17 kNm (1.7 mt))	14,560 ft. lbs. (19.6 kNm (2.0 mt))	1 Hydraulic + 1 Manual (2 Hydraulic Option)	11.4 ft. (16 ft.) 3.5 m (4.9 m)	28.0 ft./min (8.5 m/min)	630 lbs. (286 kg)	Class 3
PSC 4016 E	4,000 lbs. (1814 kg)	18,500 ft. lbs. (25.1 kNm (2.6 mt))	23,235 ft. lbs. (31.4 kNm (3.2 mt))	1 Hydraulic + 1 Manual (2 Hydraulic Option)	11.4 ft. (16 ft.) 3.5 m (4.9 m)	18.0 ft./min (5.5 m/min)	650 lbs. (295 kg)	Class 3
PSC 4016 H	4,000 lbs. (1814 kg)	18,500 ft. lbs. (25.1 kNm (2.6 mt))	23,235 ft. lbs. (31.4 kNm (3.2 mt))	1 Hydraulic + 1 Manual (2 Hydraulic Option)	11.4 ft. (16 ft.) 3.5 m (4.9 m)	40.0 ft./min (12.2 m/min)	630 lbs. (286 kg)	Class 3
PSC 4025 E	4,000 lbs. (1814 kg)	18,500 ft. lbs. (25.1 kNm (2.6 mt))	20,585 ft. lbs. (27.9 kNm (2.9 mt))	2 Hydraulic	25 ft. (7.6 m)	19.0 ft./min (5.8 m/min)	1010 lbs. (458 kg)	Class 3
PSC 4025 H	4,000 lbs. (1814 kg)	18,500 ft. lbs. (25.1 kNm (2.6 mt))	20,585 ft. lbs. (27.9 kNm (2.9 mt))	2 Hydraulic	25 ft. (7.6 m)	40.0 ft./min (12.2 m/min)	995 lbs. (451 kg)	Class 3
PSC 5025 E	5,000 lbs. (2286 kg)	32,500 ft. lbs. (44.2 kNm (4.5 mt))	34,580 ft. lbs. (49.3 kNm (5.0 mt))	2 Hydraulic	25 ft. (7.6 m)	19.0 ft./min (5.8 m/min)	1170 lbs. (530 kg)	Class 4
PSC 5025 H	5,000 lbs. (2286 kg)	32,500 ft. lbs. (44.2 kNm (4.5 mt))	34,580 ft. lbs. (49.3 kNm (5.0 mt))	2 Hydraulic	25 ft. (7.6 m)	34.0 ft./min (10.3 m/min)	1155 lbs. (525 kg)	Class 4
PSC 6025 E	6,000 lbs. (2750 kg)	38,500 ft. lbs. (52.2 kNm (5.3 mt))	43,730 ft. lbs. (58.0 kNm (5.9 mt))	2 Hydraulic	25 ft. (7.6 m)	23.0 ft./min (7.0 m/min)	1280 lbs. (580 kg)	Class 4
PSC 6025 H	6,000 lbs. (2750 kg)	38,500 ft. lbs. (52.2 kNm (5.3 mt))	43,730 ft. lbs. (58.0 kNm (5.9 mt))	2 Hydraulic	25 ft. (7.6 m)	52.0 ft./min (15.8 m/min)	1230 lbs. (560 kg)	Class 4
PSC 4329 H	8,000 lbs. (3650 kg)	43,000 ft. lbs. (58.3 kNm (5.9 mt))	49,180 ft. lbs. (66.5 kNm (6.8 mt))	2 Hydraulic	29.1 ft. (8.9 m)	60 ft./min (18.2 m/min)	2149 lbs. (975 kg)	Class 5
PSC 6229 H	10,800 lbs. (4900 kg)	62,000 ft. lbs. (84.1 kNm (8.6 mt))	68,900 ft. lbs. (93.2 kNm (9.5 mt))	2 Hydraulic	29.1 ft. (8.9 m)	60 ft./min (18.2 m/min)	2407 lbs. (1092 kg)	Class 6
PSC 7229 H	12,500 lbs. (5700 kg)	72,00 ft. lbs. (97.6 kNm (10 mt))	79,450 ft. lbs. (107.7 kNm (11 mt))	2 Hydraulic	29.1 ft. (8.9 m)	60 ft./min (18.2 m/min)	2731 lbs. (1239 kg)	Class 6
PSC 8629 H	14,000 lbs. (6400 kg)	86,000 ft. lbs. (116.6 kNm (11.9 mt))	94,676 ft. lbs. (128.4 kNm (13 mt))	2 Hydraulic	29.1 ft. (8.9 m)	60 ft./min (18.2 m/min)	2833 lbs. (1285 kg)	Class 7



OS - PALPRO39+E / E 02 / 18

Cranes shown in the leaflet are partially optional equipped and do not always correspond to the standard version. All PSC models are subject to change as PALFINGER updates, improves, and technologically advances their cranes and the industry.

Omaha Standard Palfinger
3501 S. 11th Street | Council Bluffs, IA
51501-0876 | USA
T + 1 800 279 2201

PALFINGER.COM