

RAILGATE SERIES
STANDARD MODELS WITH DOCK-FRIENDLY PLATFORMS



DOCK-FRIENDLY RAILGATE MODELS

Dock-friendly models feature folding RF platforms able to achieve non-obstructing positions for forklift or dock loading. Also included are a closure-assist torsion bar and maintenance-free bushings, making them some of the best liftgates ever seen in a loading bay.

◀ 89-20 RF 45-12



1



2



3

PLATFORM DESCRIPTIONS

- RF 45-6** Two-piece Extruded Aluminum w/ 45" loading depth (15" flipper) + 6" taper **(30" base height)**
- RF 45-12** Two-piece Extruded Aluminum w/ 45" loading depth (10" flipper) + 12" taper **(35" base height)**
- RF 50-6** Two-piece Extruded Aluminum w/ 50" loading depth (15" flipper) + 6" taper **(35" base height)**

Dock-friendly platforms fold and can be lowered in the vertical position to allow for easy dock or forklift loading.

DOCK-FRIENDLY, STEEL-FRAME MODELS FOR 96" WIDE BODIES

ONE-YEAR STANDARD WARRANTY

	Model Number	Load Area	Taper	Travel	Gate Weight
1600 lb. Capacity	<u>Folding Aluminum Platforms</u>				
	89-16 RF 45-6	89 x 45	6	32 - 54	674
	89-16 RF 45-12	89 x 45	12	32 - 54	688
	89-16 RF 50-6	89 x 50	6	32 - 54	695
2000 lb. Capacity	<u>Folding Aluminum Platforms</u>				
	89-20 RF 45-6	89 x 45	6	32 - 54	674
	89-20 RF 45-12	89 x 45	12	32 - 54	688
	89-20 RF 50-6	89 x 50	6	32 - 54	695

DOCK-FRIENDLY, ALUMINUM-FRAME MODELS FOR 96" WIDE BODIES¹

	Model Number	Load Area	Taper	Travel	Gate Weight
1600 lb. Capacity	<u>Folding Aluminum Platforms</u>				
	A89-16 RF 45-6	89 x 45	6	32 - 54	550
	A89-16 RF 45-12	89 x 45	12	32 - 54	564
	A89-16 RF 50-6	89 x 50	6	32 - 54	571
2000 lb. Capacity	<u>Folding Aluminum Platforms</u>				
	A89-20 RF 45-6	89 x 45	6	32 - 54	550
	A89-20 RF 45-12	89 x 45	12	32 - 54	564
	A89-20 RF 50-6	89 x 50	6	32 - 54	571

ADDITIONAL BODY SIZE

Body Size	Model	Load Width
90"	85	85
102"	95	95





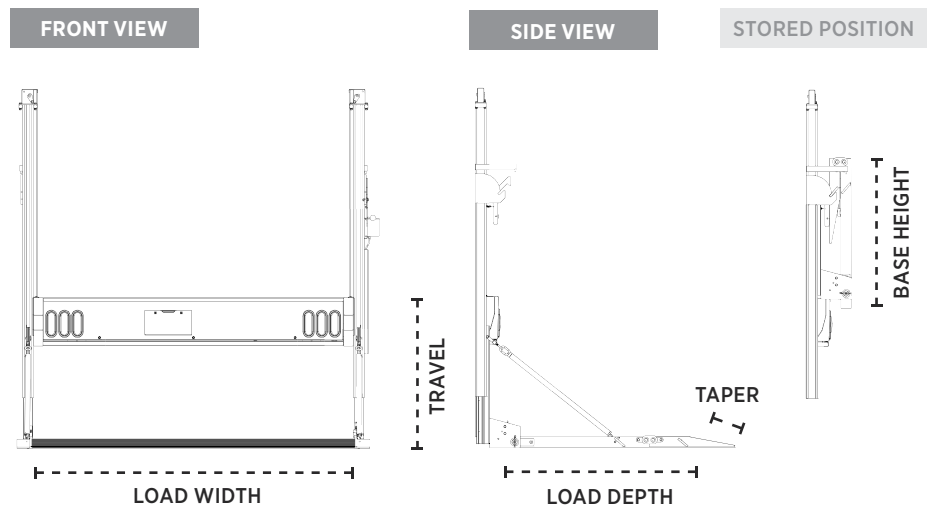

- Aluminum frame railgates require mounting flanges which affect installation dimensions, visit www.tommygate.com for additional information.
- For detailed dimensions, visit www.tommygate.com





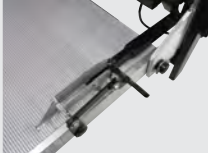

DOCK-FRIENDLY RAILGATE DIMENSIONS²



FEATURES & OPTIONS

STANDARD RAILGATE MODELS

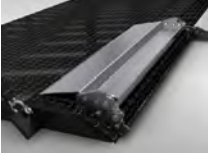
STANDARD FEATURES		DOCK-FRIENDLY MODELS	FIXED PLATFORM MODELS
	Recessed Light Kit	●	●
	Safety-trip Bar	●	●
	Self-close System	-	●
	Aluminum Sliders	●	●
	Power Cable with Full-length Ground	●	●
	Circuit Breaker	●	●
	Fixed and Timed Toggle Control	●	●

AVAILABLE OPTIONS		DOCK-FRIENDLY MODELS	FIXED PLATFORM MODELS
	Recessed LED Light Kit	●	●
	Above-bed Travel	●	●
	Dual Controls (w/ pendant)	●	●
	Taper-integrated Cart Stops	●	●
	Split Retention Ramps	-	●
	Rubber Platform Bumpers	●	●

- Standard
- Optional
- Not Available

Every pump and motor that goes into any Tommy Gate hydraulic lift must pass an assembly floor test in addition to quality control inspections by the vendor.

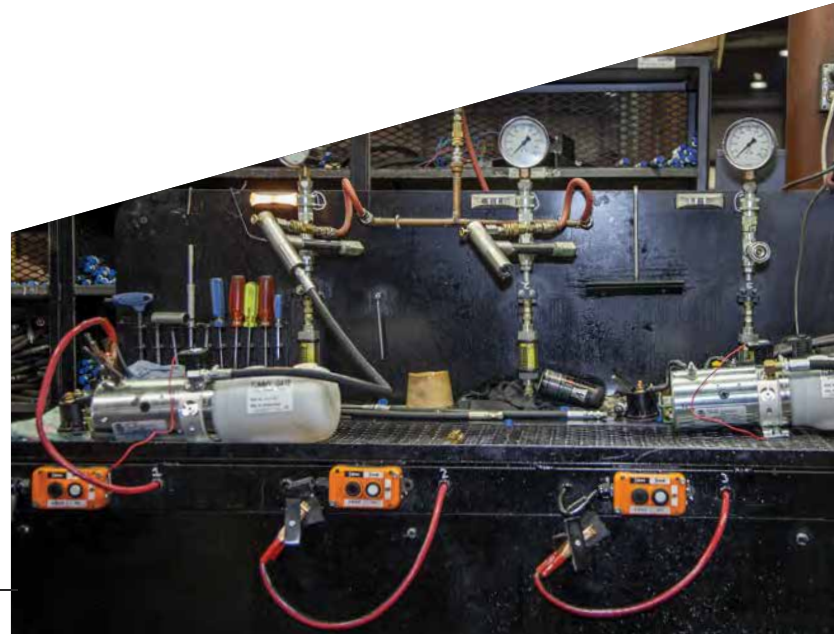

PLATFORMS

STANDARD RAILGATE MODELS

PLATFORM MATERIALS

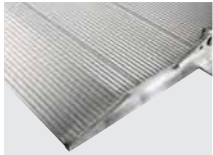
		DOCK-FRIENDLY MODELS	FIXED PLATFORM MODELS
	Steel Treadplate	-	●
	Extruded Aluminum	●	●

SPLIT CART STOPS

All railgate models with Extruded Aluminum platforms are available with taper-integrated, foot-activated, dual cart stops.



SPLIT RETENTION RAMPS

Steel-platforms (standard models 89 & 85 only) are available with add-on retention ramps.



ALUMINUM PLATFORM DEPTHS

Extruded aluminum platforms (on fixed platform models) are available in any depth, 35"-70", in 5" increments. Platforms are comprised of interlocking extrusions of 6061-T6 aircraft-quality aluminum.



GAS-BOTTLE RACK PLATFORM

GBR - 30" Loading Depth

