

# TopLifter

Tailgates By **THIEMAN**

*Raising Performance to New Levels*

## Model TT-15

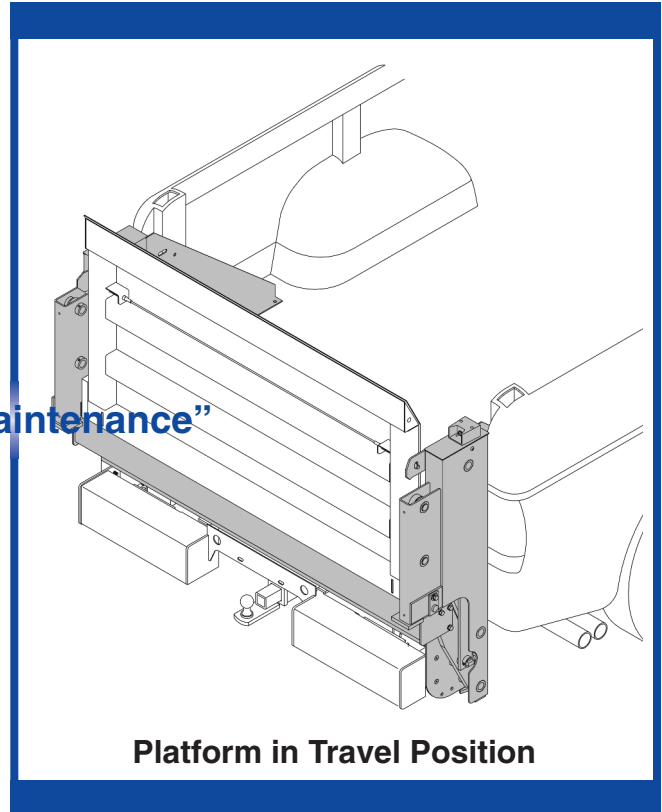
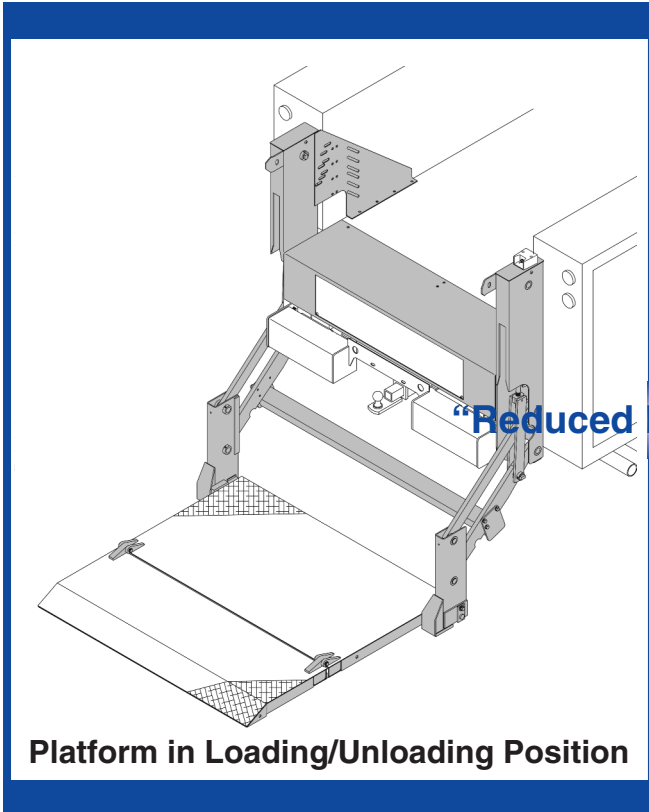

### FEATURING:

- Reduced Maintenance
- New Streamline Design
- Meets TMC Electrical Guidelines
- Direct Dual Cylinder Lift, No Chains or Cables, Wide Opening to Truck Bed
- Heavy-Duty Steel Diamond Plate Platform
- Fully Enclosed Power Unit & Cylinders
- Fast & Easy Installation
- Two Piece Bumper (for use with frame attached receivers)

The THIEMAN TT Series is completely assembled into one compact unit - ready to run. Simply bolt and/or weld it to the truck and connect the battery cable. Installation is fast and easy. And years from now, it will be just as simple to remount the TT-15 model on a new truck. The lifting mechanism is completely enclosed for a neat appearance and protection from the elements. A two piece bumper, for use with frame attached receivers, is standard on the TT15. The THIEMAN TT's overall design makes it the toughest liftgate available in its class.



# Features, Benefits and Specifications

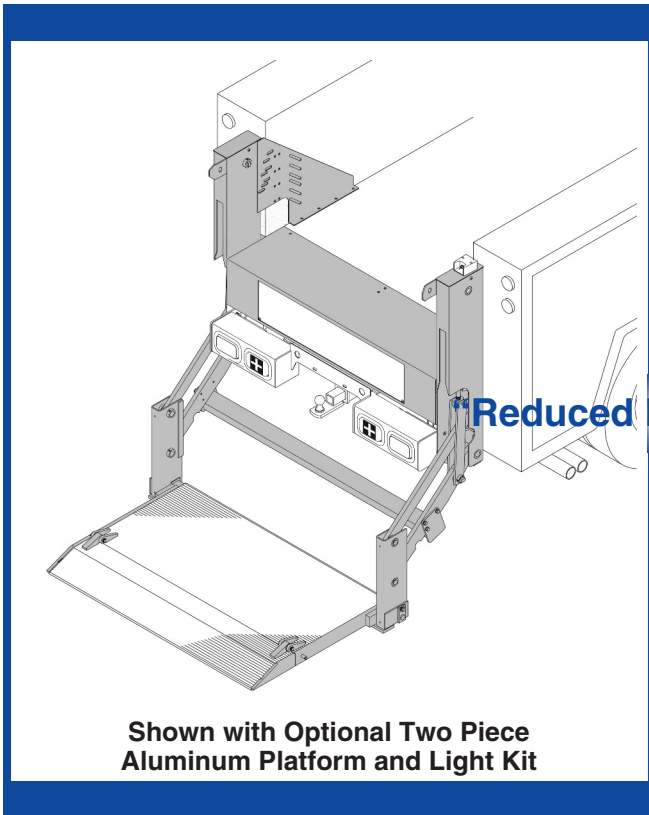

Shown with Optional Two Piece Aluminum Platform and Light Kit

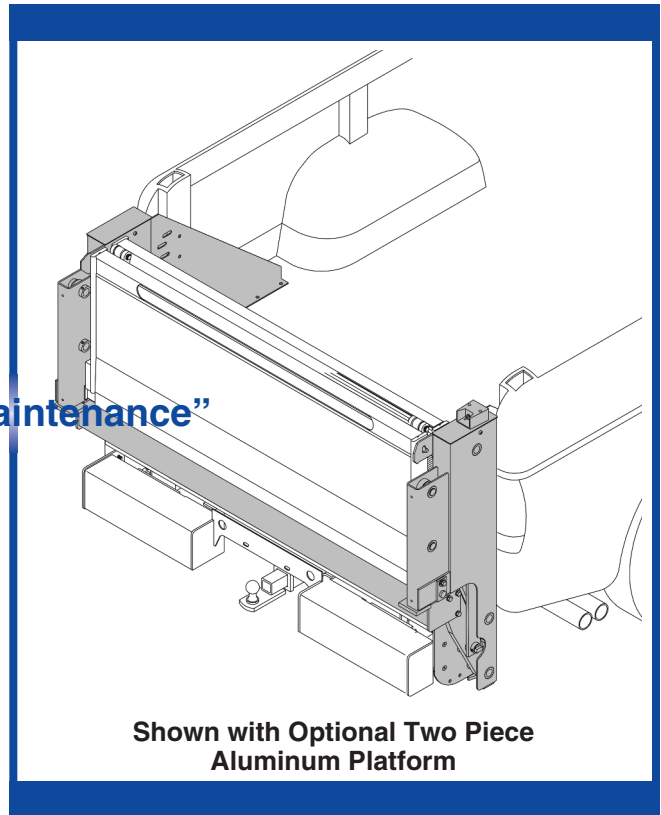

Shown with Optional Two Piece Aluminum Platform

“Reduced Maintenance”

## STANDARD FEATURES AND BENEFITS:

- Dual Cylinder Design for Maximum Lifting Stability.
- Meets all TMC Electrical Guidelines for Reduced Service Requirements.
- Enclosed Cylinders and Power Units for Better Reliability and Easy Accessibility.
- Molded Toggle Switch (Environmentally Sealed).
- Torsion Assist on all 42" Deep Steel Platforms for Easier Opening & Closing of Platform.
- Skid Resistant Steel Diamond Plate Platform for Added Safety.
- Adjustable Cylinder Clevis for Easy Platform and Bed Alignment.
- 150 Amp Circuit Breaker for Electrical Protection
- Two-Piece Bumper for use with Receivers

## AVAILABLE OPTIONS FOR TT-15:

- Platform Options Including: Expanded Metal, 2-Piece Folding, Extruded Aluminum, Bar Grate, Galvanized
- Remote Pendant Control
- In-Cab Shut Off Switch
- Light Kit
- 5000 lb. Tow Rated Bumper
- Tire Rack
- Special Platform Widths and Depths

Model #	Platform	Rated Load Capacity Lbs.	Approx. Inst. Wt.	Bed Height Range
TT15-4926	49" x 26" + 5"	1500	497	30" - 45"
TT15-5326	53" x 26" + 5"	1500	508	30" - 45"
TT15-5626	56" x 26" + 5"	1500	523	30" - 45"
TT15-4942	* 49" x 42" + 5"	1500	606	30" - 45"
TT15-5342	* 53" x 42" + 5"	1500	619	30" - 45"
TT15-5642	* 56" x 42" + 5"	1500	658	30" - 45"

\*Two-Piece Platform

TT15-49" x 26"/49" x 42" .....Utility and Service Bodies (Liftgate Frame Dimensions: Post OD=55.00, Post ID=48.62)

TT15-53" x 26"/53" x 42" .....Utility and Service Bodies (Liftgate Frame Dimensions: Post OD=59.00, Post ID=52.62)

TT15-56" x 26"/56" x 42" .....1988 and Later GMC/Chevrolet Pickup, 1994 and Later Dodge Pickup, 1997 and Later Ford Pickup

Distributed By:



*Raising Performance to New Levels*

600 East Wayne Street  
 Celina, Ohio 45822  
 Phone: 419-586-7727 or  
 800-524-5210  
 Fax: 419-586-9724  
 www.thiemantailgates.com  
 info@thiemantailgates.com