



LIFTGATES

ILUK OWNER'S MANUAL

ECN-M0256 Rev. 1.4, Date 07-11-2013 Part #90-0513-100

*PALFINGER Liftgates, LLC. 15939 Piuma Ave., Cerritos, CA 90703
Tel (888)-774-5844 Fax (562)-924-8318*

*PALFINGER Liftgates, LLC. 572 Whitehead Road, Trenton, NJ 08619
Tel (609)-587-4200 Fax (609)-587-4201*

Visit our website at www.palfinger.com for up to date information and notifications

If you received this product with damaged or missing parts,

Please contact PALFINGER Liftgates at (888)-774-5844

Table of Content

Table of Figures	II
1. Important Notes.....	1
1.1 Attention	1
1.2 Important Notes	1
1.3 General Information.....	2
2. Safety Information.....	4
3. Basic Parts in Detail.....	6
3.1 General View of Liftgate	6
3.2 Circuit Board Connector Cables	7
3.3 Control Panel.....	8
4. Maximum Load and Placing of Load on Platform.....	9
5. Operation of Liftgate	10
NOTE: Never slide platform in or out with load on the platform.....	10
5.1 Operating the ILLUK by Control Box.....	10
5.1.1 General Instructions for the ILLUK Unfolding Process	10
5.1.2 Special Instructions for ILLUK 66 Unfolding Process	12
5.2 Operation by Hand Held Remote Control.....	13
5.3 Operation by Foot Control (optional on ILLUK 33)	14
5.4 Operation by Wireless hand Held Remote (optional)	14
6. Preventive Maintenance and Quick Check.....	15
6.1 Maintenance and Care	15
6.2 Trailer to Tractor Connection Test	16
6.3 Lubrication.....	17
6.3.1 Lubrication Plan	17
6.3.2 Checking and Changing the Oil.....	19
6.3.3 Recommended Hydraulic Fluids	19
6.4 Decal Placement and Inspection	20
6.5 Quick Check List.....	22
7. Troubleshooting.....	23
7.1 Basic Function Check.....	23
7.1.1 LIFTGATE is completely DEAD (No Clicking or Movement at all)	23
7.1.2 ON-OFF switch on, but all functions are dead.....	25
7.1.3 Warning Lights on, after switch is turned off.....	26
7.1.4 Platform tilts down before it reaches the ground.....	26
7.2 Electrical and Hydraulic Schematic.....	27
7.2.1 Wiring Diagram	27

7.2.2	Electrical Schematic.....	28
7.2.3	Connector Overview	29
7.2.4	Hydraulic Schematic	30
7.3	Functional Description of Hydraulics when Operating.....	31
7.3.1	Slide Out Function	31
7.3.2	Lower Down and Auto Tilt Function.....	31
7.3.3	Level Out Activity	31
7.3.4	Lift Up Function.....	32
7.3.5	Slide In Function	32
7.4	ILUK Push-Pull Valving.....	33
8.	Needed Information for Ordering Spare Parts and Repairs	34
8.1	Ordering Spare Parts.....	34
8.2	Repairs.....	34
9.	Warranty	35
10.	Contact Address	36

Table of Figures

Figure 1: ILUK Under Slider	6
Figure 2: Center Point of Load.....	9
Figure 3: Load Diagram (ILUK 33 to 66)	9
Figure 4: Hand Held Remote Control with Plug & Socket Wiring.....	13
Figure 5: Lube Points	18
Figure 6: Power Pack (Side View).....	19
Figure 7: Power Pack (Top View).....	19
Figure 8: Main Wiring	27
Figure 9: Electrical Schematic	28
Figure 10: Connector Overview	29
Figure 11: Hydraulic Schematic.....	30

List of Tables

Table 1: Maintenance Schedule.....	15
Table 2: Recommended Hydraulic Fluids	19
Table 3: Warranty Coverage Schedule.....	35

1. Important Notes

1.1 Attention

Before starting any operations of the liftgate, please read and understand this OWNER'S MANUAL. Its intention is to act as a guide for the operation personal as well as to give help with preventive maintenance but does not take place of unauthorized usage or repair by unqualified personnel.

Please contact your nearest PALFINGER Liftgates distributor or PALFINGER Liftgates in California or New Jersey for assistance if you have questions regarding installation, operation or maintenance.

This owner's manual applies to the following models: **ILUK Under Slider 33, 44, 55 & 66**



This is the safety alert symbol. It is used to alert you to potential personal injury hazards. Obey all safety messages that follow this symbol to avoid possible injury.

1.2 Important Notes

This PALFINGER Liftgate is an electro-hydraulically driven lift gate, designed to be stored underneath the truck or trailer for ultimate dock loading as well as offering up to seven foot platform.

The Hydraulic Power Unit (HPU) is easily accessible for service and exchange. The whole assembly slides out and can be serviced at that point. To exchange the Hydraulic Power Unit (HPU), two hoses and the battery cables need to be disconnected.

The platform folded in half is supported by two arms, linked with a torsion tube. The platform in a stored position acts as the under ride guard. Lifting actions are carried out by hydraulic cylinders mounted on the lift arms.

Two hydraulic tilt cylinders, one on each side of the lift arms are controlling the platform's tilting action. This enables the platform to maintain its position throughout the lift mode, regardless of the terrain.

The hydraulic cylinders are equipped with solenoid operated valves located at the port of each cylinder which prevents the platform from lowering accidentally unless the operator is activating the controls. This system also enables you to store the lift gate without a separate platform latch.

The piston rods are treated against corrosion and also protected with plastic or rubber boots to protect from road gravel and dirt. The HPU is equipped with a built-in pressure relief valve, which prevents overloading when lifting or tilting up.



The valves do not prevent overloading of the platform when lowering or tilting down.



The electric supply is taken from the vehicle battery. If the vehicle battery is not sufficient or not existing (like on trailer units), an auxiliary battery kit needs to be installed. The electric control power is protected via a 20 Amp fuse and an on-off switch. The switch has L.E.D. lights indicating when the control power is on. (Trailer application have an on-off switch located in the lockable control box).

The liftgate is operated from an outside control box which is located on the curbside underneath the body. A standard 2-button hand held remote control is also supplied with the lift. Foot controls are standard (except for the ILUK 33), which enables the operator to handle the cargo and operate the lift by foot. A variety of different products can be purchased with the PALFINGER Liftgate as well.

1.3 General Information

REMEMBER!

It is the fleet manager's responsibility to educate the operator on the liftgate and its intended use. The operator's attention should be drawn to the permitted load limits and an understanding of the operation to ensure the safety throughout the operation.

ONE-MAN OPERATION!

Never let an "outsider" operate the liftgate while you are handling the cargo.

A "misunderstanding" can result in serious personal injury.



In the interest of safety it is important that all operating personnel properly understand the functions of the lift gate, possible hazards, dangers, the load limits and load positioning for that specific unit.

IMPORTANT NOTICE!



Before the operator uses the lift gate, they should be thoroughly familiar with the lift's functions and usage according to the following:

1. Improper operation of this lift can result in serious personal injury. Do not operate unless you have been properly instructed, have read and are familiar with the operation instructions. If you do not have a copy of the instructions please obtain them from your employer, distributor or lessor, as appropriate, before you attempt to operate the lift.
2. Be certain the vehicle is properly and securely stopped before using the lift.

-
3. Always inspect this lift for maintenance or damage before using it. If there are signs of improper maintenance, damage to vital parts or slippery platform surface, do not use the lift. Do not attempt your own repairs unless you are specifically trained.
 4. Do not overload. See the Rating Label on the unit for the rated load. Remember that this limit applies to both raising and lowering operations.
 5. Each load should be placed in a stable position as near as possible to the body of the truck/trailer.
 6. Never stand in, move through or allow anyone else to stand in or move through the area in which the lift operates, including that area in which a load might fall.
 7. This is not a passenger lift. Do not ride the lift with unstable loads or in such a manner that a failure would endanger you. The lift is not equipped with a back-up system to prevent falling cargo in the event of a failure.

The maximum loads must be observed and followed!



IMPROPER USE



It is not permitted to use the tail lift:

- As an elevating work platform
- To push loads
- To carry people (Only the operator may travel on the platform)
- To clear snow

Please read through the operational and technical description of this PALFINGER Liftgate.

Thank you for choosing PALFINGER Liftgates.

2. Safety Information

This manual follows the Guidelines set forth in “ANSI Z535.4-2007” for alerting you to possible hazards and their potential severity.

DANGER

! **DANGER** indicates an imminently hazardous situation which, if not avoided, **will result** in death or serious injury.

WARNING

! **WARNING** indicates potentially hazardous situation which, if not avoided, **could result** in death or serious injury.

CAUTION

! **CAUTION** indicates a potentially hazardous situation which, if not avoided, **may result** in minor or moderate injury.

CAUTION

CAUTION without the safety alert symbol is used to address practices not related to personal injury. *(In this manual we use it to alert you to potentially hazardous situation which, if not avoided, may result in property damage.)*

NOTICE

NOTICE without the safety alert symbol is used to address practices not related to personal injury. *(In this manual we use it to alert you to special instructions, steps, or procedures.)*

⚠ WARNING

Improper operation of this liftgate may result in severe personal injury or death. DO NOT operate unless you have been properly instructed, have read and are familiar with the procedures in this manual. We have designed this manual to illustrate the steps needed for the basic operation of this ILUK liftgate. It also provides safety information and simple preventive maintenance tips.

NOTICE

This manual is not intended for use as a repair or troubleshooting guide. Repairs should be performed by an PALFINGER Liftgates Authorized Service Center.

This Manual has been designed for use in conjunction with the ILUK series liftgate only which is designed for different capacities. You have different options to determine the type of your Liftgate:

- 1) Refer to the serial number tag on the Liftgate.

- 2) Ask your employer or lessor.

- 3) Call your PALFINGER Liftgates Authorized Service Center for assistance.

- 4) Call PALFINGER Liftgates for assistance in the USA at 888-774-5844. You can also contact PALFINGER Liftgates by fax (562) 924-8318, or on the internet- www.PALFINGER.com

If you are facing any problems or are in need of repair, contact PALFINGER Liftgates for information regarding experienced and trained Authorized Service Center in your area.

Replacement manuals are available, just call us & order your manuals for FREE.

3. Basic Parts in Detail
3.1 General View of Liftgate

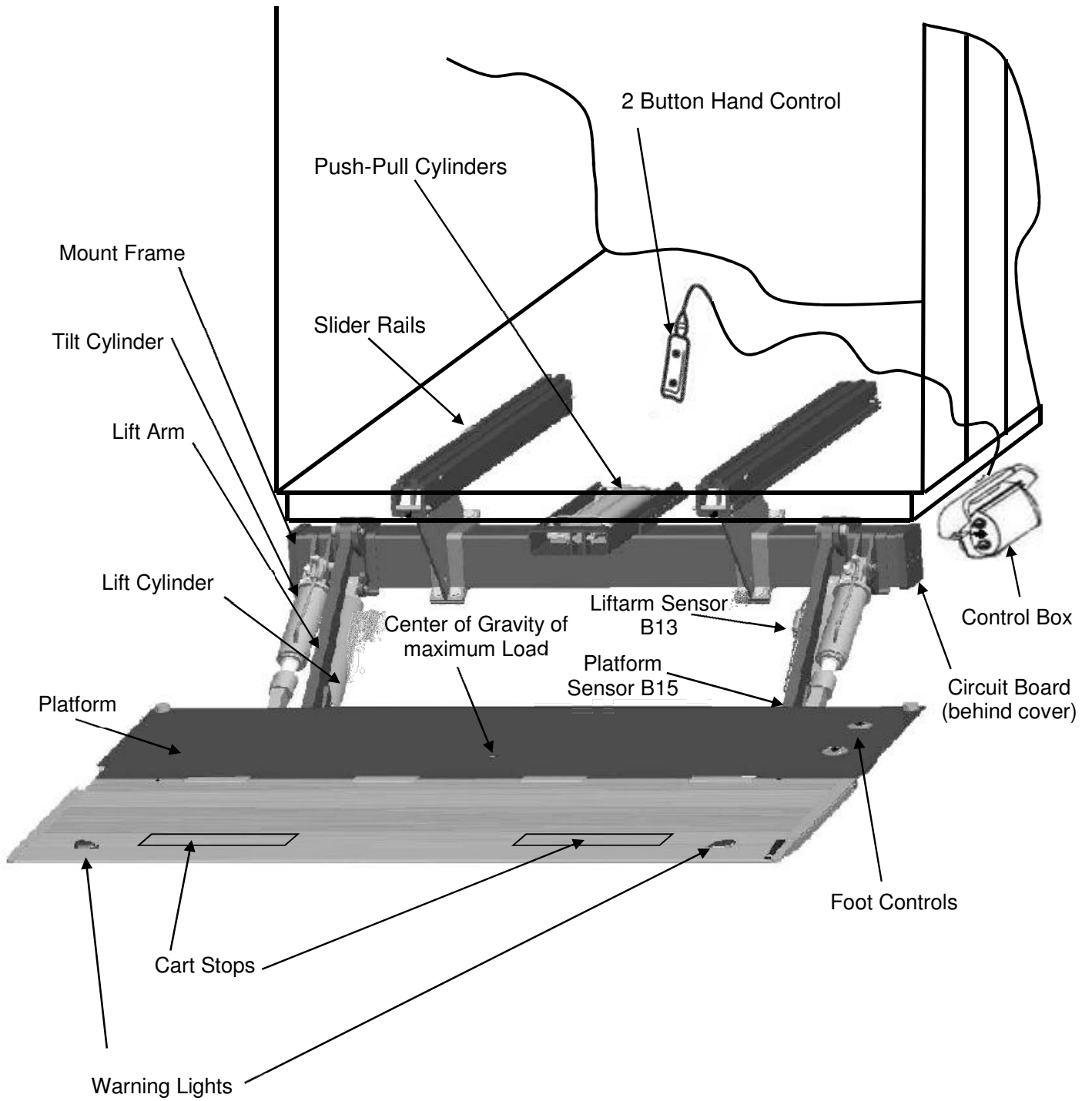
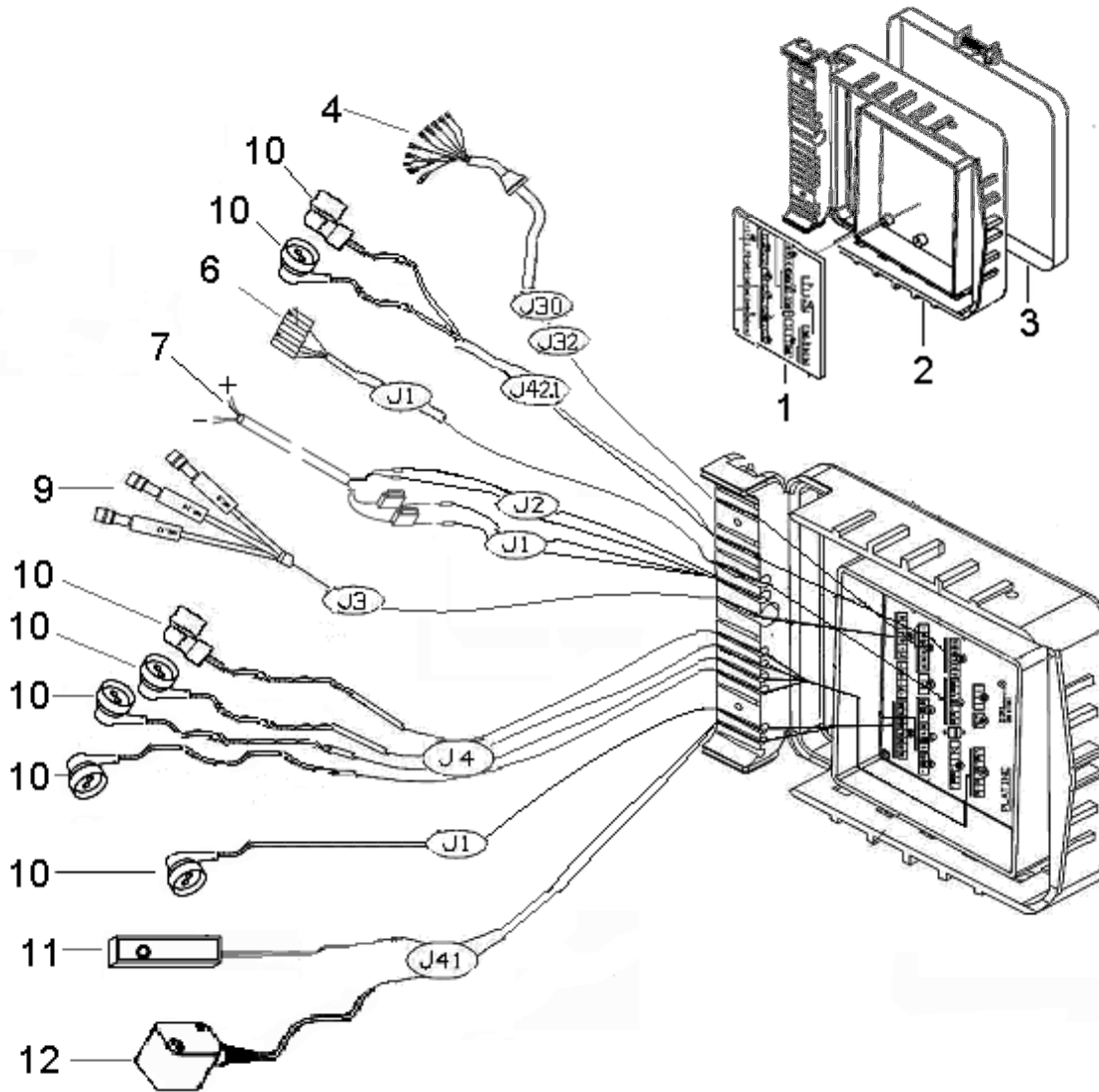

Figure 1: ILLUK Under Slider

3.2 Circuit Board Connector Cables



No.	Description	Part No.
1	PC- board <i>K plus</i>	P-200 7193UK
2	Cover with hinge - for control system	P-200 7474
3	Clamp for cover	P-201 0169
4	Wire harness for control box (J30+J32)	P-200 7410
6	Wire harness for power pack (J1)	P-201 0018
7	Wire harness for circuit board power (J1+J2)	P-200 7406
9	Wire harness for warning lights and foot control (J3)	P-134 2776
10	Cable for solenoid valve (J1), (J4), (J42.1)	P-6725 4198
11	Sensor B13 for lift arm (J41)	P-133 2476
12	Sensor B15 for platform (J41)	P-133 2485

3.3 Control Panel

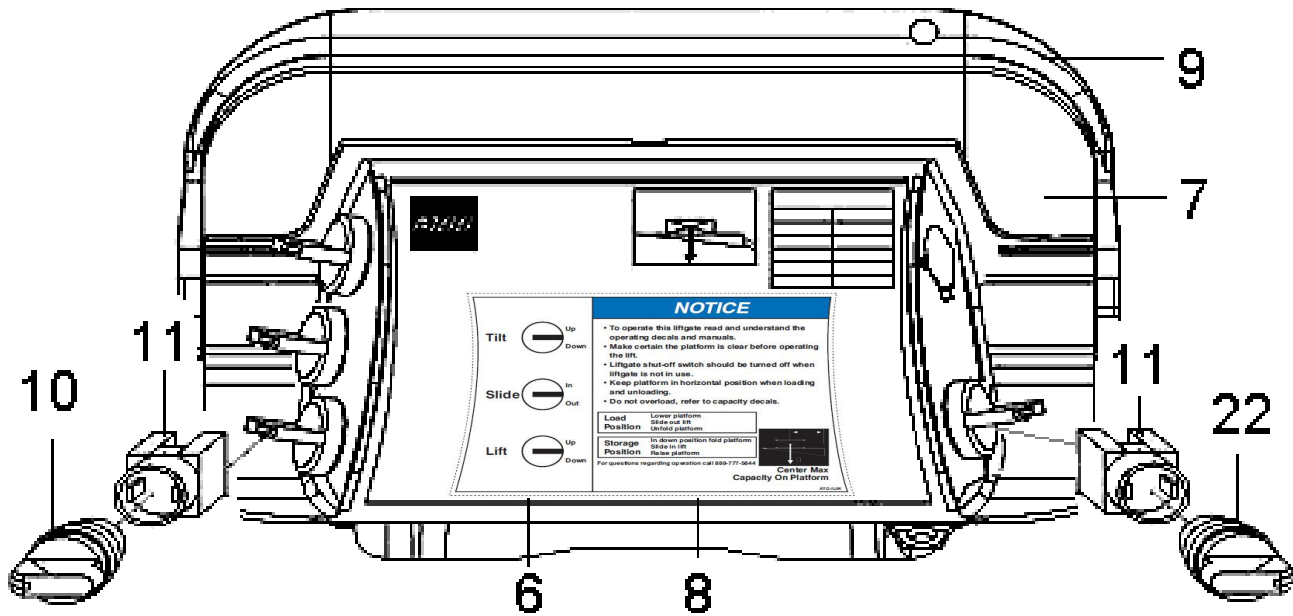

No.	Description	Part No.
6	Control box with PC-board and harness	P-200 9304
	Control box with cable (without PC-board)	P-200 7415
7	Complete outer plastic box	P-200 9205
8	Operation lable	ATG-ILUK
9	Flip down lid	P-200 7476
10	Momentary turn knob	P-200 7456
11	Contact block	P-200 7457
22	On- off switch	P-200 9186

3.4

4. Maximum Load and Placing of Load on Platform

Every PALFINGER Liftgates liftgate is rated up to a maximum load. The point of maximum load is rated at a defined distance. The center point of maximum load is at 24" for all ILUK lift gates from start of Truck or Trailer Body, as shown in Figure 2.

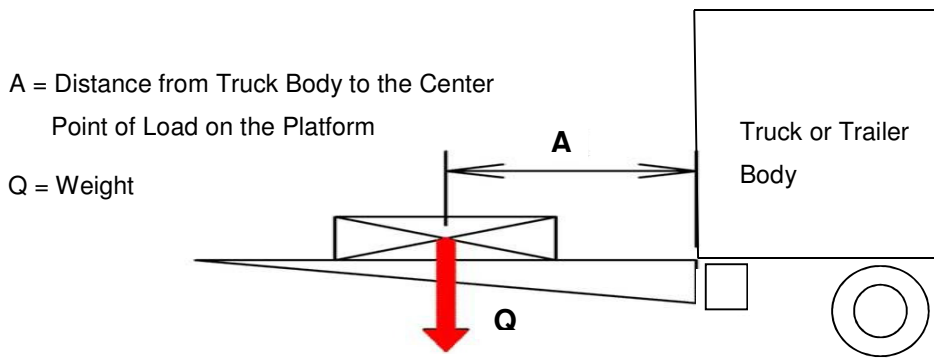

Figure 2: Center Point of Load



By increasing this distance the maximum load of the lift gate is decreasing.



An overview about the rating depending, on the distance from the end of the platform is shown in the following load diagram.

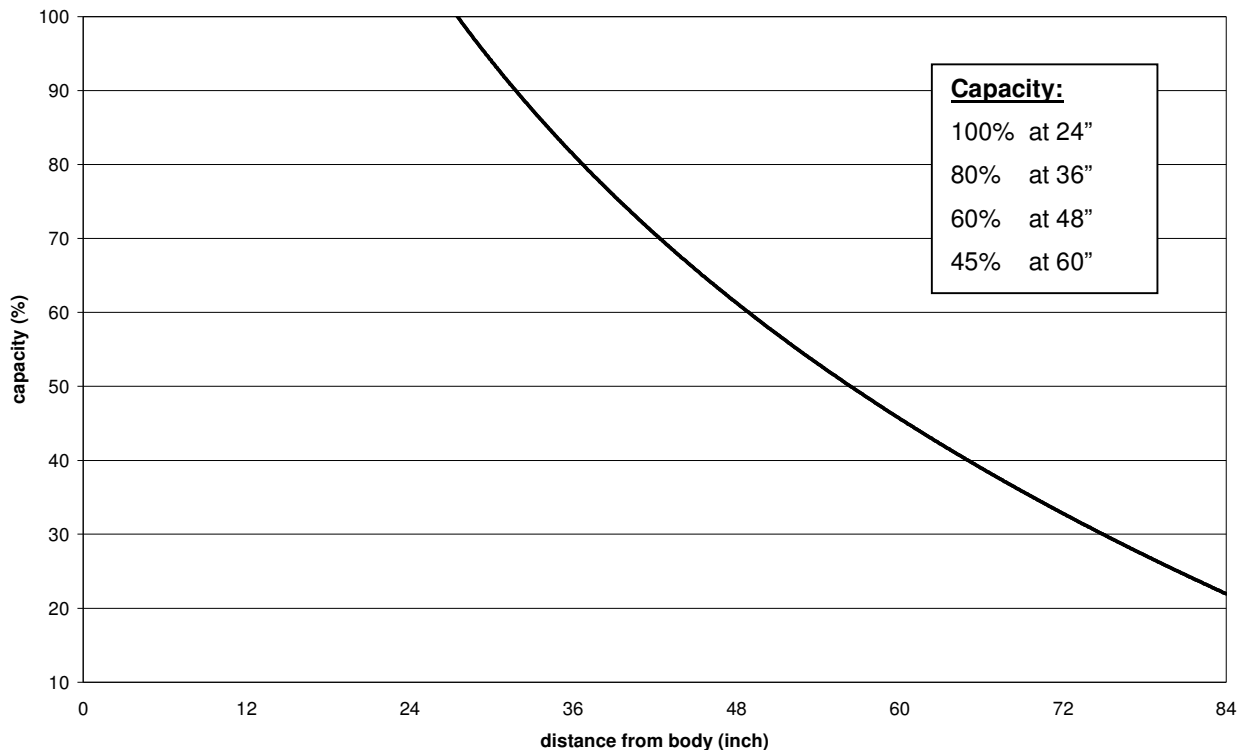

Figure 3: Load Diagram (ILUK 33 to 66)

5. Operation of Liftgate

Before use: Turn Control power to "ON". All lift gate functions can be controlled with the 3-button control box, which is mounted on the curb side of the truck or trailer.



NOTE: Never slide platform in or out with load on the platform.

5.1 Operating the ILUK by Control Box

5.1.1 General Instructions for the ILUK Unfolding Process

1. Turn on the liftgate by rotating the ON-button on the right side of your Control Box.
Warning-Lights will start flashing.

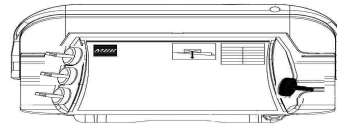

2. Lowering down
By rotating the bottom button **down** you will lower the lift gate from its storage position



3. Slide out the liftgate
Rotate the center button **down** to slide out the gate completely until you hit the stops.

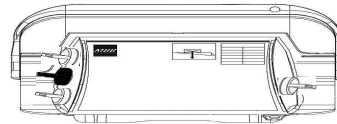

4. Unfold the platform manually by using the nylon strap

5. Check out auto tilt function
Rotate the bottom button **down** to lower the platform to the ground. If you continue holding the switch, the tip of the platform will automatically tilt down.

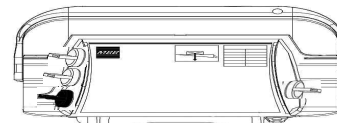

6. Auto tilt up to level and raising
To raise platform to the body floor, rotate the lower switch **up**.

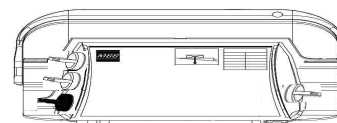

7. Fold the platform manually

Lower down the platform to the ground. To fold the platform, **flip** the tip section onto the main section.

8. Sliding in

Rotate the center button **up** to slide the lift gate underneath your vehicle till the gate is in its final position and does not move further back.

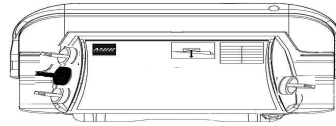

9. Raising up

By rotating the bottom button **up** you will raise the lift gate up to its storage position.

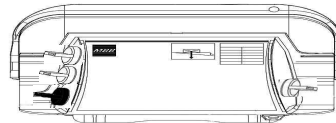

10. Turn off all functions by rotating the right button into the OFF position. The flashing lights turn off.

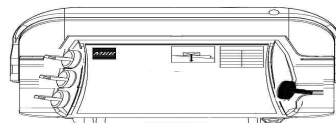

5.1.2 Special Instructions for ILUK 66 Unfolding Process

The platform of the ILUK 66 has a **longer** tip section in stored position. Because of this specific configuration additional steps must be taken to ensure an optimal platform position to the bed height of the Trailer or Truck. Please read and understand the following operational steps before starting to unfold your ILUK 66.

1. Turn on the liftgate by rotating the ON-button on the right side of your Control Box.
Warning-Lights will start flashing.

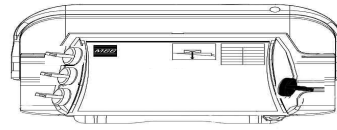

2. Lowering down
By rotating the bottom button **down** you will lower the lift gate from its storage position

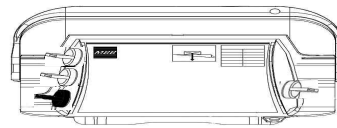

3. Slide out the liftgate
Rotate the center button **down** to slide out the gate completely until you hit the stops.

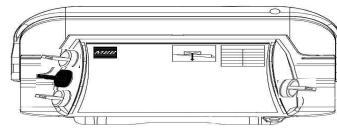

4. Unfold the platform manually by using the nylon strap.
In special cases you have to tilt down the platform to clear the back sill because of the uneven split.

5. Check out auto tilt function
Rotate the bottom button **down** to lower the platform to the ground. If you continue holding the switch, the tip of the platform will automatically tilt down.

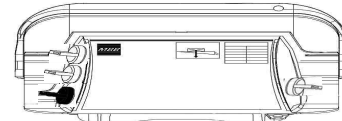

6. Raising up
Before Raising up the ILUK 66 platform, make sure to slide **in** the gate in accordance with the decal ATG-BRP on your trailer. The rear/left side of your Control Box **MUST** align with the arrow on the decal.
Set the platform angle to the final position and rotate the lower switch **up** to raise the platform.

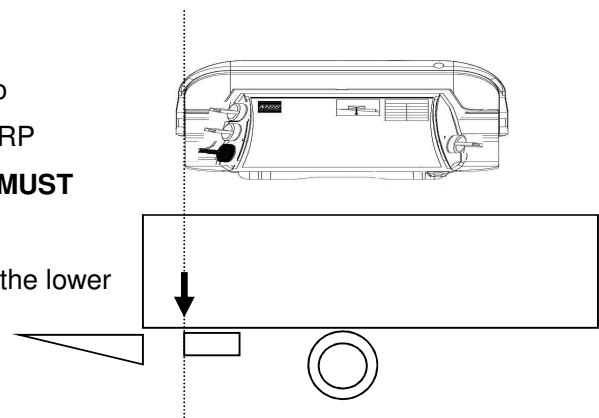

Store the lift gate in accordance with step 7 to 10, as shown in Chapter 5.1.

5.2 Operation by Hand Held Remote Control



Hand Controls are NOT weatherproof and are designed to be stored inside body in holster or in weatherproof box.

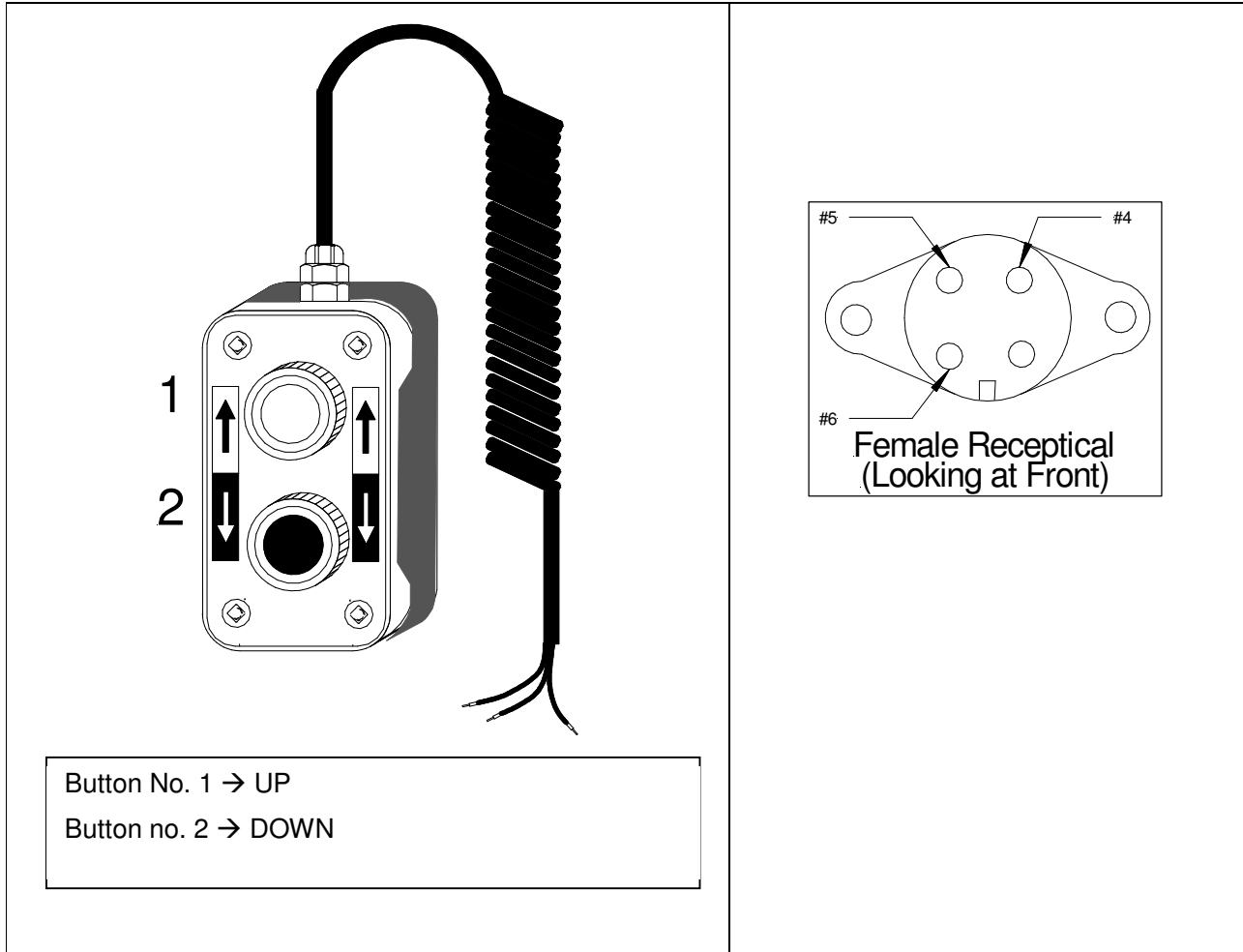

Figure 4: Hand Held Remote Control with Plug & Socket Wiring

5.3 Operation by Foot Control (optional on ILLUK 33)

DOWN:

Step on switch 1 and hold – wait between one and three seconds before you step on switch 2.

→ For auto tilt, stay on the switches till platform starts tilting.

UP:

Step on switch 2 and hold – wait between one and three seconds before you step on switch 1.

→ The platform will tilt up to preset position before raising.

IF BOTH SWITCHES ARE NOT ACTIVATED
WITHIN THREE SECONDS, START OVER.

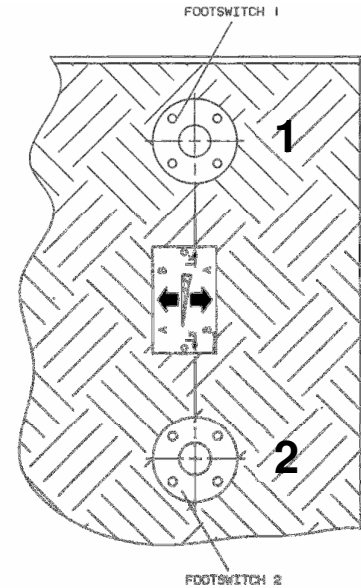

DIAGRAM NO.3:
FOOT CONTROL ON THE PLATFORM

5.4 Operation by Wireless hand Held Remote (optional)

1) By pushing the “START” button the remote will be activated.

2) Each function has a separate button.

Function is displayed on the button.

3) After finishing using the gate, push the red “STOP” button.

The wireless remote control will be deactivated.



6. Preventive Maintenance and Quick Check

The ILUK needs preventive maintenance to perform at its fullest capability. Lubricate and inspect regularly. Also, check that all details are not damaged: Hoses, cables, controls, etc.



REPAIR OR REPLACE IMMEDIATELY FAULTY PARTS



6.1 Maintenance and Care

The following inspection and maintenance should be performed at the recommended intervals depending on operation and amount of cycles or at the time when the unit shows any signs of damage or abuse. Remember that the secret to a long life of your PALFINGER Liftgates is to maintain it through preventive care.

* Recommended bases for inspection and maintenance	Depending on use	Daily	Monthly	Quarterly
cleaning	x			
general lubrication of pins and bushings				x
general lubrication of Slider Rails with WD-40 and Push-Pull Cylinder zerks with grease				x
oil level inspection				x
oil change	x			
check hydraulic hoses and pipes for leaks				x
check controls and connections				x
check pins and pin retaining bolts			x	
check batteries and connections				x
check warning labels and other safety equipment for effectiveness and visibility		x		
visual check for loose or missing parts and un-usual noise during operation		x		
check lock bolts and pins for tightness				x
check complete function of gate		x		
check mounting brackets of lift gate to frame for cracks or damage visually		x		

Table 1: Maintenance Schedule

CROSS TEST ON ENTIRE CHARGE SYSTEM SINGLE POLE PLUG SET UP

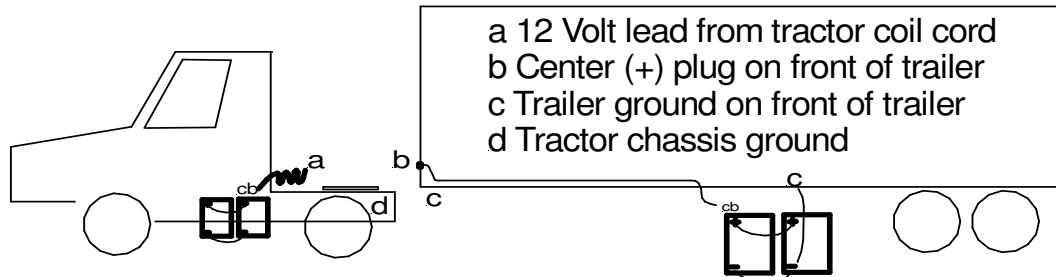

Testing of full system using a battery load tester:

Start with testing each individual battery on both tractor and trailer before proceeding to check the system:

Tractor Test:

1. Ground battery load tester on tractor chassis point (d)
Hook up positive load tester cable on positive pole of single pole plug at end of tractor coil cord (a)
Run load test- This will test entire circuit on tractor including ground from batteries to tractor chassis

Trailer Test:

2. Ground battery load tester on trailer chassis (c)
Hook up positive cable on positive pole of single pole plug receptacle on trailer (b)
Run load test - This will test entire circuit on trailer including circuit breakers & ground between trailer batteries and trailer chassis.

Tractor and Trailer charging system test while connected:

3. Ground battery load tester on tractor chassis (d)
Hook up positive cable on positive pole of single pole plug receptacle on trailer (b)
Run load test- This will test entire circuit on tractor - trailer including ground between tractor and trailer and circuit breaker on trailer.

A simple low amp voltage test at the front of the trailer or at the tractor will not show insufficient connections or ground problems

6.3 Lubrication

Properly lubricated, the ILUK PALFINGER Liftgate will ensure longevity. Therefore, lubricate the lift at the same time as the truck/trailer. Grease more frequently if the liftgate is heavily used. The liftgate should be greased every 500 cycles (depending on use – estimated every 3 month).

Check the oil level in the tank. The level should be between the two marks 5 and 7 when the platform is tilted down at ground level in stored position. Use a good quality of hydraulic fluid, ISO 32. Change oil at least once a year, preferably in the fall before the weather gets cold. The operation of the lift gate will accumulate condensation and some dirt which can interfere with the lift gate functions.

6.3.1 Lubrication Plan

All bearing points must be lubricated in accordance with the maintenance intervals.



Make sure NOT to lubricate the rails with grease as it catches all dirt and mud.



Avoid this by using WD-40 for rail lubrication.

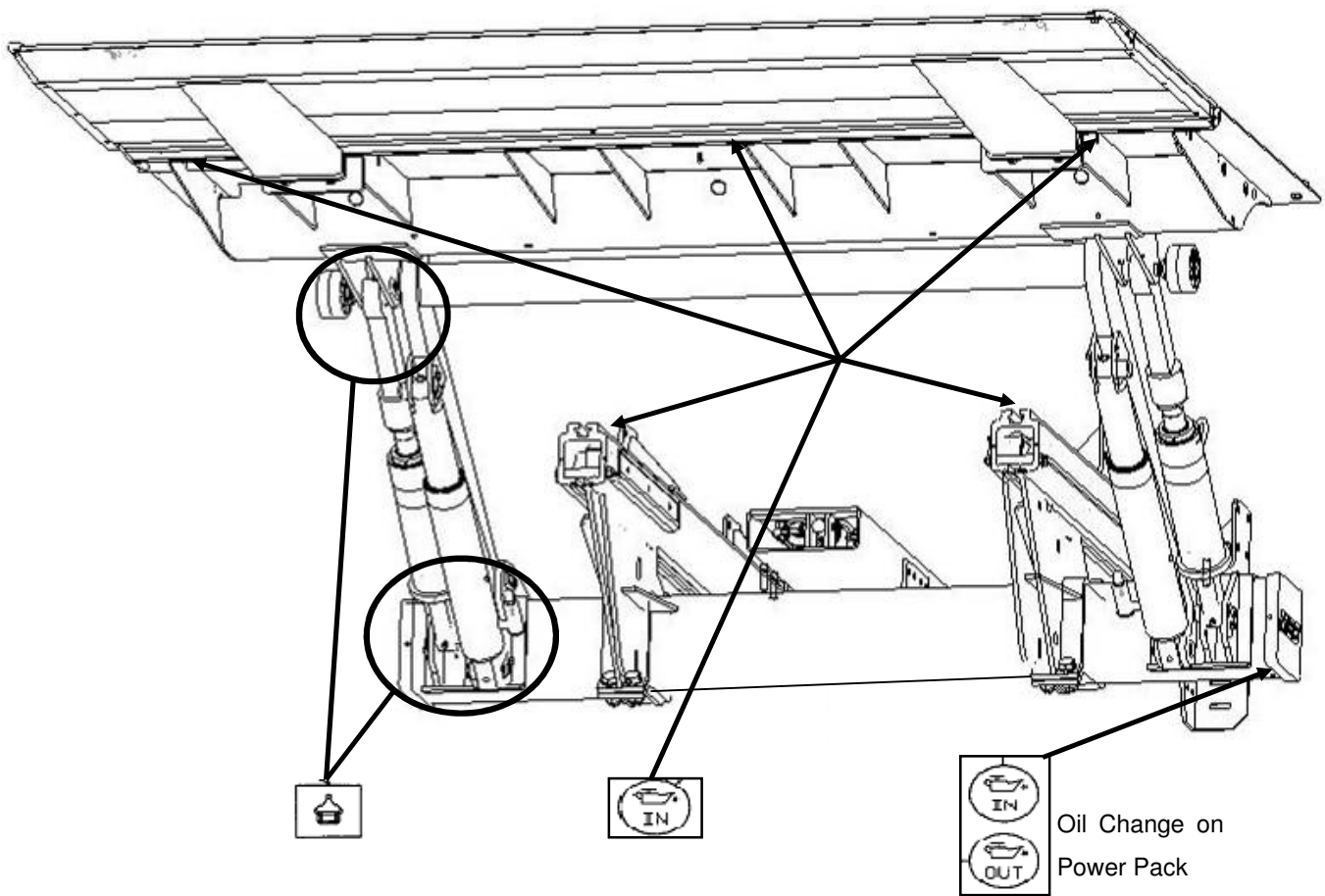
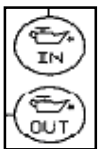

Figure 5: Lube Points



Location of Grease Zerks (9 on each side, 18 total)



Oil level in the power pack tank (see marking inside of power pack reservoir)



Platform hinges, Slide Rails and optional Cart Stops (use WD-40 spray for lubrication)

6.3.2 Checking and Changing the Oil

Check the quality of hydraulic fluid. If bad, take the following steps to change the oil. In stored position, lower gate to ground and tilt platform down, remove lock bolt. Pull the power pack out till you can reach the oil filler cap. Unscrew the oil drainage bolt (bottom of tray) and let the fluid drain out of the reservoir into an approved container. If the reservoir is empty fill it up with hydraulic oil, as shown on table 2.

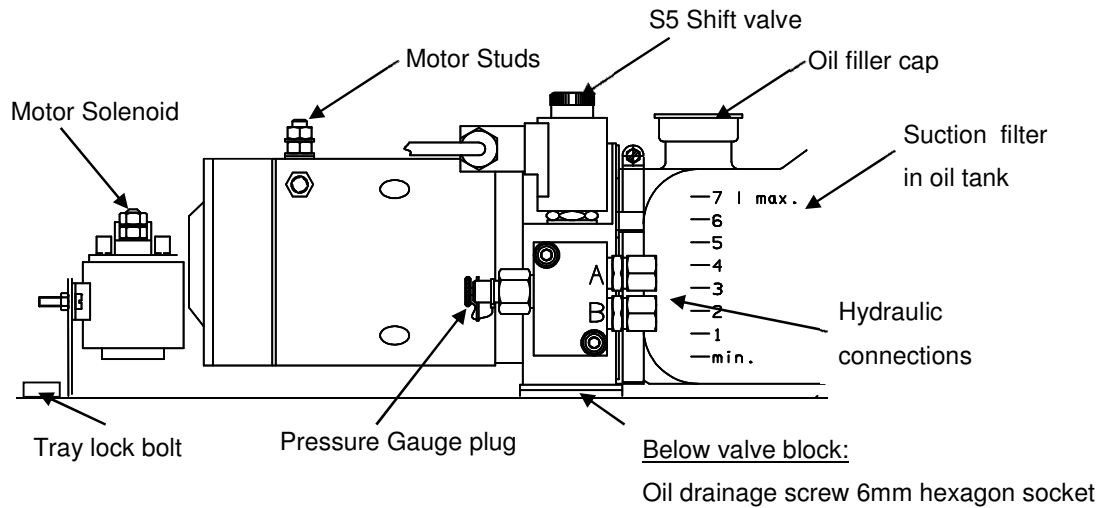

Figure 6: Power Pack (Side View)

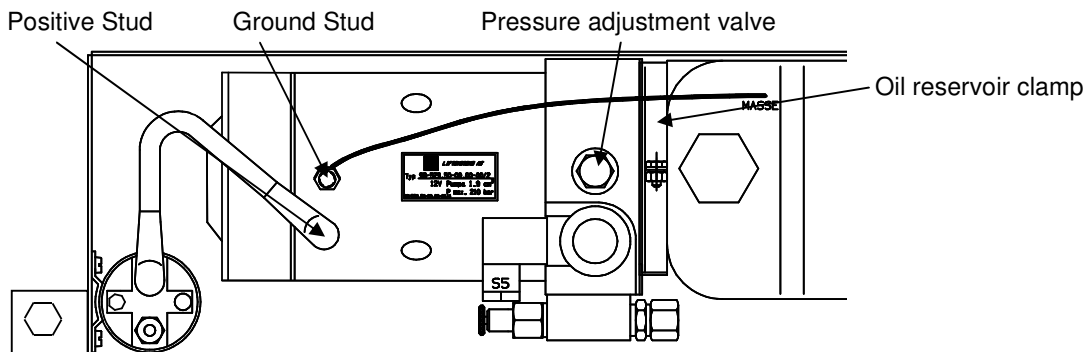

Figure 7: Power Pack (Top View)

6.3.3 Recommended Hydraulic Fluids

TEMP. RANGE	BRAND	
-10 TO 150 F	EXXON MOBIL OIL CHEVRON ROSEMEAD	UNIVIS J26 DTE 13M AW MV32 MV 150 (32)
-50 TO 150 F	MOBIL SHELL	DTE 13M AERO FLUID 4
EXTREME COLD TEMPERATURE:	USE MILITARY SPEC:	MIL H5606

Table 2: Recommended Hydraulic Fluids

6.4 Decal Placement and Inspection

For operator's safety, all decals appearing in "Decal Kit" must be in a conspicuous place on control side of liftgate to be read by operator. This is typically a combination of decals on the liftgate and truck body. Please make sure to place the maximum capacity decal (D) on driver and curb side.

- (A) 1 ATG-URGWA - Urgent warning: Elevating gate instructions
- (C) 1 ATG-FT - Notice for Foot Control (if applicable)
- (D) 2 ATG-XXXX - Max. Capacity (please check the serial number plate to find out your specific capacity)
- (E) 1 ATG ILUK - Operational Instructions (placed on your Control Box).
- (F) 2 ATG-WLH - Warning: liftgate can crush
- (G) 2 ATG-CTN - Caution: Always stand clear of platform area
- (H) 1 ATG-BKR - Circuit Breaker Reset (must be located at the circuit breaker)
- (J) 1 ATG-RESET - Circuit Breaker Protection
- (K) 1 ATG-CAB - Liftgate Shut-Off (must be placed next to the Shut-Off Switch)
- (L) 1 ATG-WNG - Warning: Use handle to open (must be located underneath handle (main section))

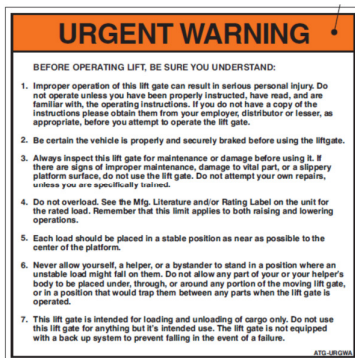

Decal - A



Decal - D



Decal - G

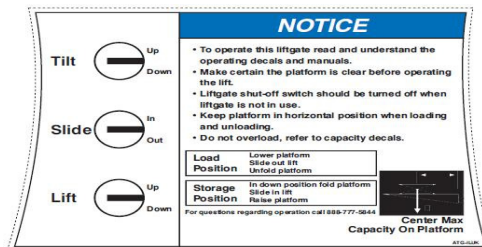

Decal - E

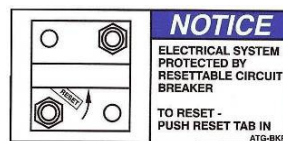

Decal - H



Decal - J

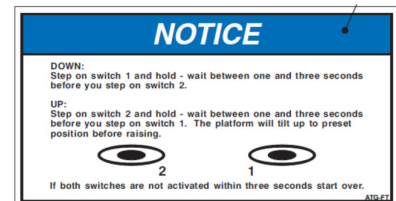

Decal - C



Decal - F



Decal - K

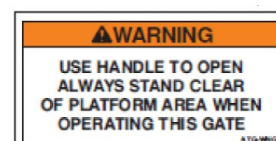

Decal - L

The picture below will help you to place all decals visible in order to get maximum operational safety.

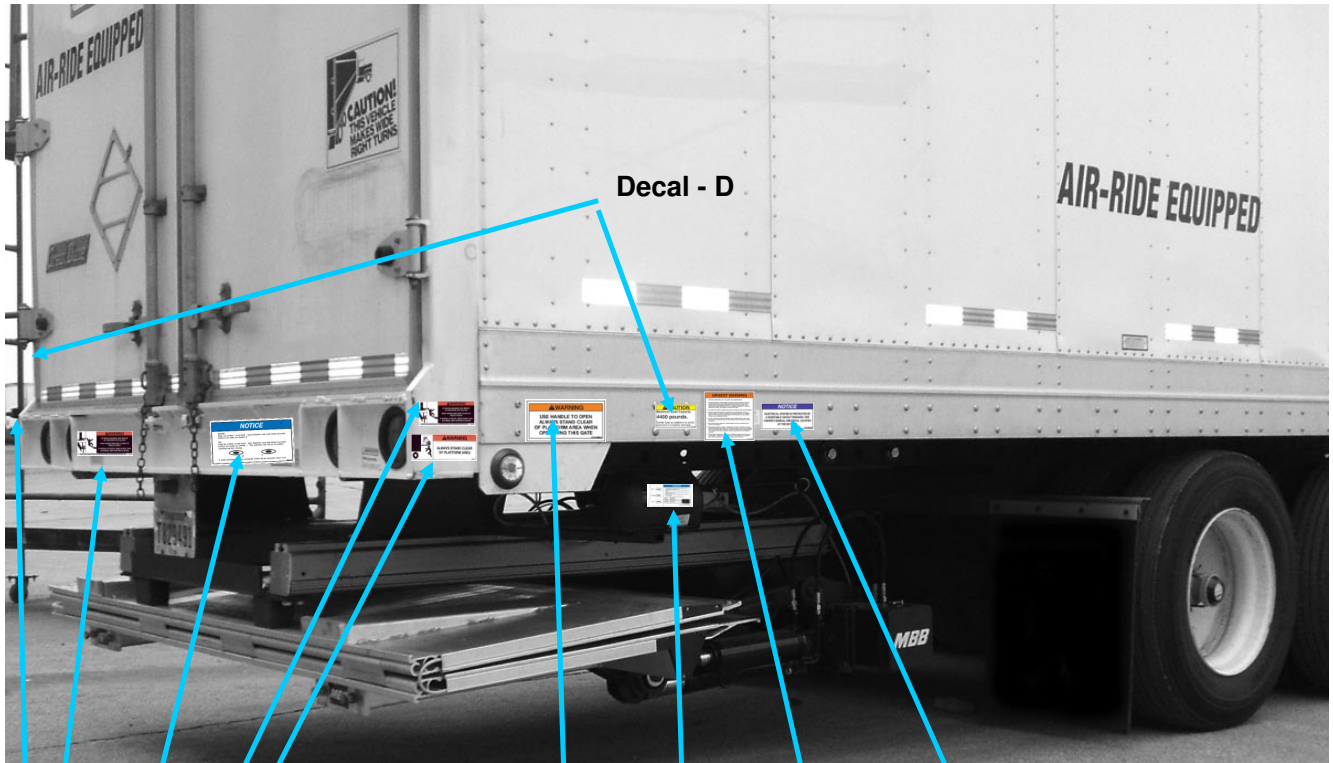

Decal - D

AIR-RIDE EQUIPPED

Decal - C

Decal - F

Decal - G

Decal - L

Decal - E

Decal - A

Decal - J

6.5 Quick Check List

1. Operate the liftgate throughout its entire operation and check for noise and damage such as bent parts or cracked welds.
2. Inspect all welds and fasteners that attach the mount frame to the truck. All pins and bolts that connect the lift arm to the mount frame and to the platform.
3. Visually inspect the hydraulic lines for damage, scratches, bending or leakage.
4. Inspect the cylinders for leakage and that the cylinder pins are secured with lock bolts.
5. Check the oil level when the platform is down at ground level. The level should fall between the markings 5 and 7 on the tank. We recommend replacing oil after the first 1200 cycles, after that on a yearly basis in the fall before winter begins.
6. Check for oil leakage around the power pack and inside mount tube. Tighten or replace components if needed. If you perform work on any hydraulic components bleed the air out of the system by operating all functions several times.
7. Check all electrical connections. Clean and protect battery terminals and check for tightness.
8. Inspect all the terminals on the solenoid-operated valves at the port of the cylinder. Lubricate the terminals for better protection from oxidation if needed. Please check the valve block on the back of the main tube and its connections additionally.
9. Grease all zerks on the lift gate and make sure they all take grease. Sometimes it helps to operate the lift gate while you do this. There are 18 zerks.
10. Test all the lift gate functions, if possible with maximum loads placed according to load diagrams.
11. Check the function of the pressure relief valve.
12. When performing daily checks and you find any kind of damage that can make the use of the liftgate dangerous, it must be repaired before using. All repairs should be made by an authorized technician. Use only original spare parts. If in doubt contact your PALFINGER Liftgates distributor or call PALFINGER Liftgates directly.



Do not cover up any accidents or damage; it can be dangerous for you and your co-workers.

7. Troubleshooting

ATTENTION:



Dangerous injuries possible from tools short circuiting main battery connections.



Every time you are finished troubleshooting, close the rubber cover on the curbside of the mount frame. **REINSTALL THE PLASTIC STRAP ON THE RUBBER COVER WHEN FINISHED!!**



Please check the following points before looking for faults:

- Please change oil after working on hydraulic unit (removal of valves, opening of cylinder etc.)
- There is a possibility of injury if somebody other than an authorized technician works on the electrical system!
- Injuries are possible if short circuits are caused by tools on the main battery connections.

7.1 Basic Function Check

7.1.1 LIFTGATE is completely DEAD (No Clicking or Movement at all)

1. Check the ON-OFF switch.

To activate and start operating the ILUK you will have to turn on the ON-OFF switch, which is located on the right side of your Control Box, as shown below.



2. Check the circuit breaker at the main batteries.

Every truck has a circuit breaker on top of the main battery. If you have a studio unit, or a trailer, you will also find an auxiliary battery kit as shown in the pictures below (“Truck Battery” and “Auxiliary Battery”). If circuit breaker reset arm is popped out, push it back in as shown on the decal ATG-BKR next to your breaker or on battery box lid.

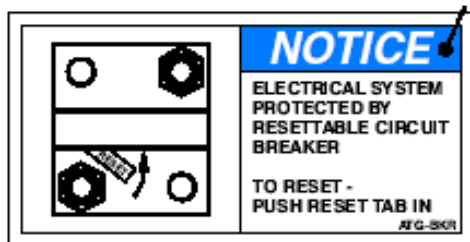
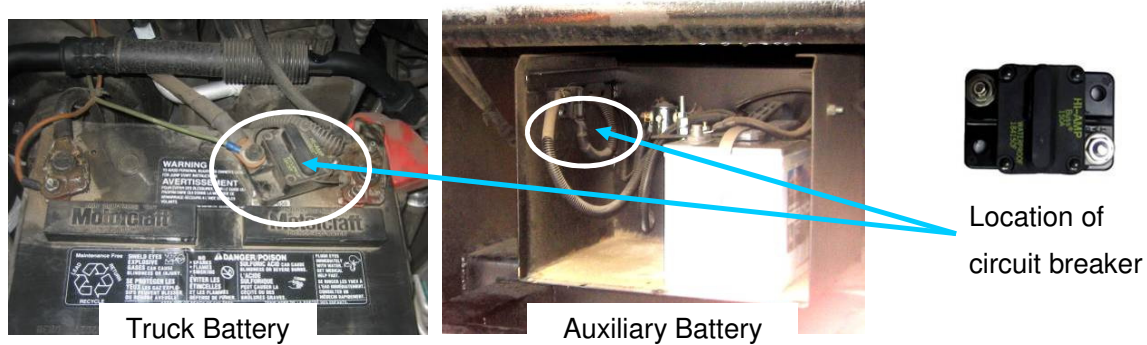

Reset your Circuit Breaker

3. Are the vehicle batteries charged?

Check batteries and the truck/trailer charging system. Start truck and run engine in fast idle for charging the batteries. If liftgate starts working, recharge batteries.

4. Check the fuse at the power pack.

In the Hydraulic Power Unit next to the motor you will find two fuses. Check for burned fuses and replace it with the same type.

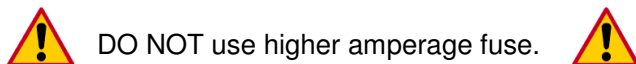

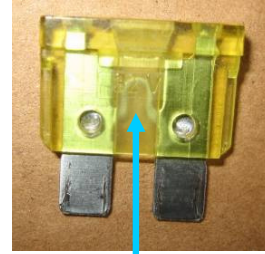
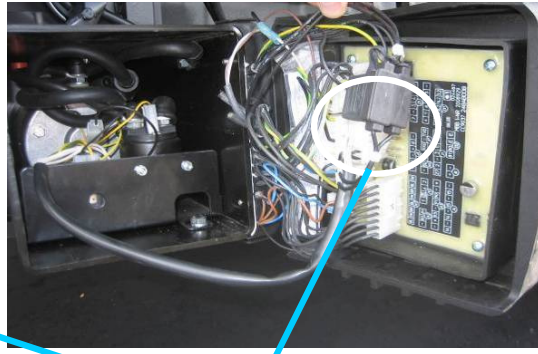
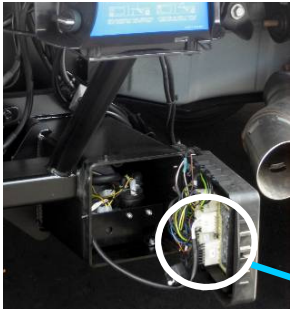

Open this cap to check the fuses

Replace fuse when metal bridge is broken

5. Is the connection to ground in power pack OK?
Is the ground connection from the tail lift to vehicle OK?
6. Check the oil level in the power pack reservoir.
7. Are there any damages on mechanical or electrical parts (such as damaged cables)?

7.1.2 ON-OFF switch on, but all functions are dead

Possible malfunctions:

1. Short in hand held remote or its wire → unplug Hand-Control.
2. Short in control box wire → remove plug J-30.

After disconnecting plugs – reboot board by unplugging J-1 for 5 seconds and plug it back.

7.1.3 Warning Lights on, after switch is turned off

- B-15 is not working.

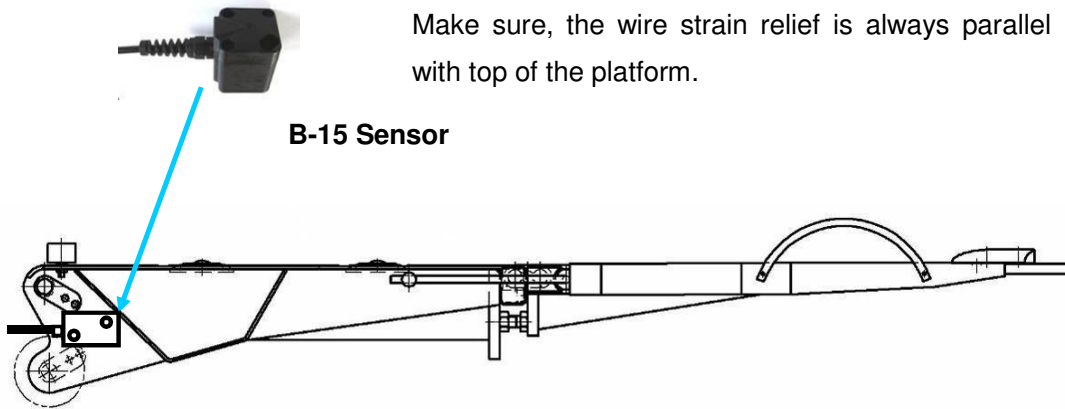

7.1.4 Platform tilts down before it reaches the ground

- Adjust B-13 lift arm switch.
- B-13 is not working → unplug J-41 (gate operates without sensor but loses auto-tilt).

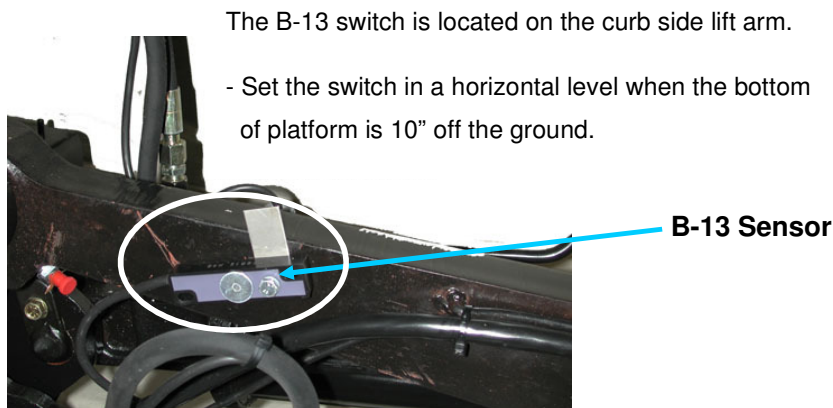

If gate is still not working, take Truck/Trailer to a repair station.



7.2 Electrical and Hydraulic Schematic

7.2.1 Wiring Diagram

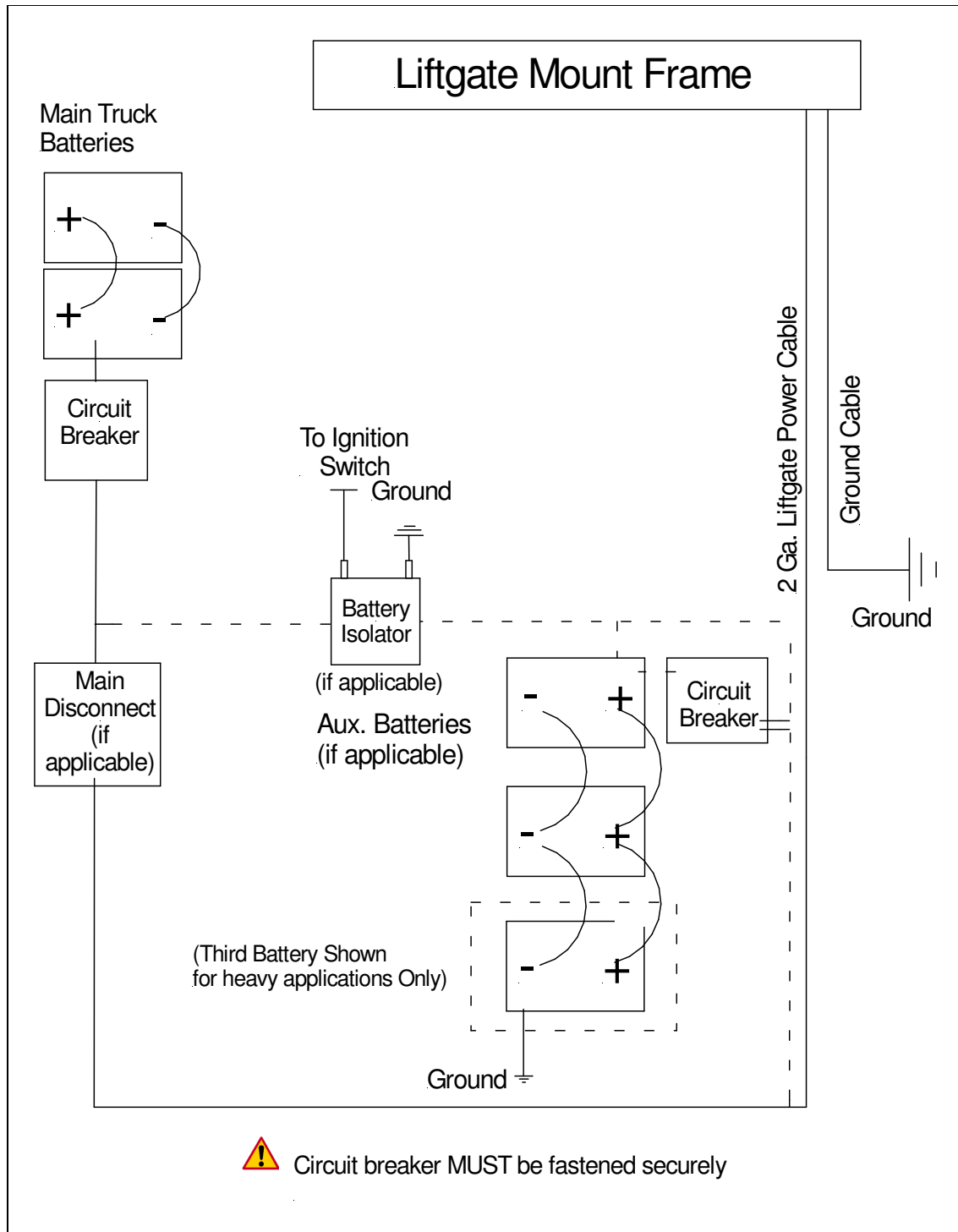
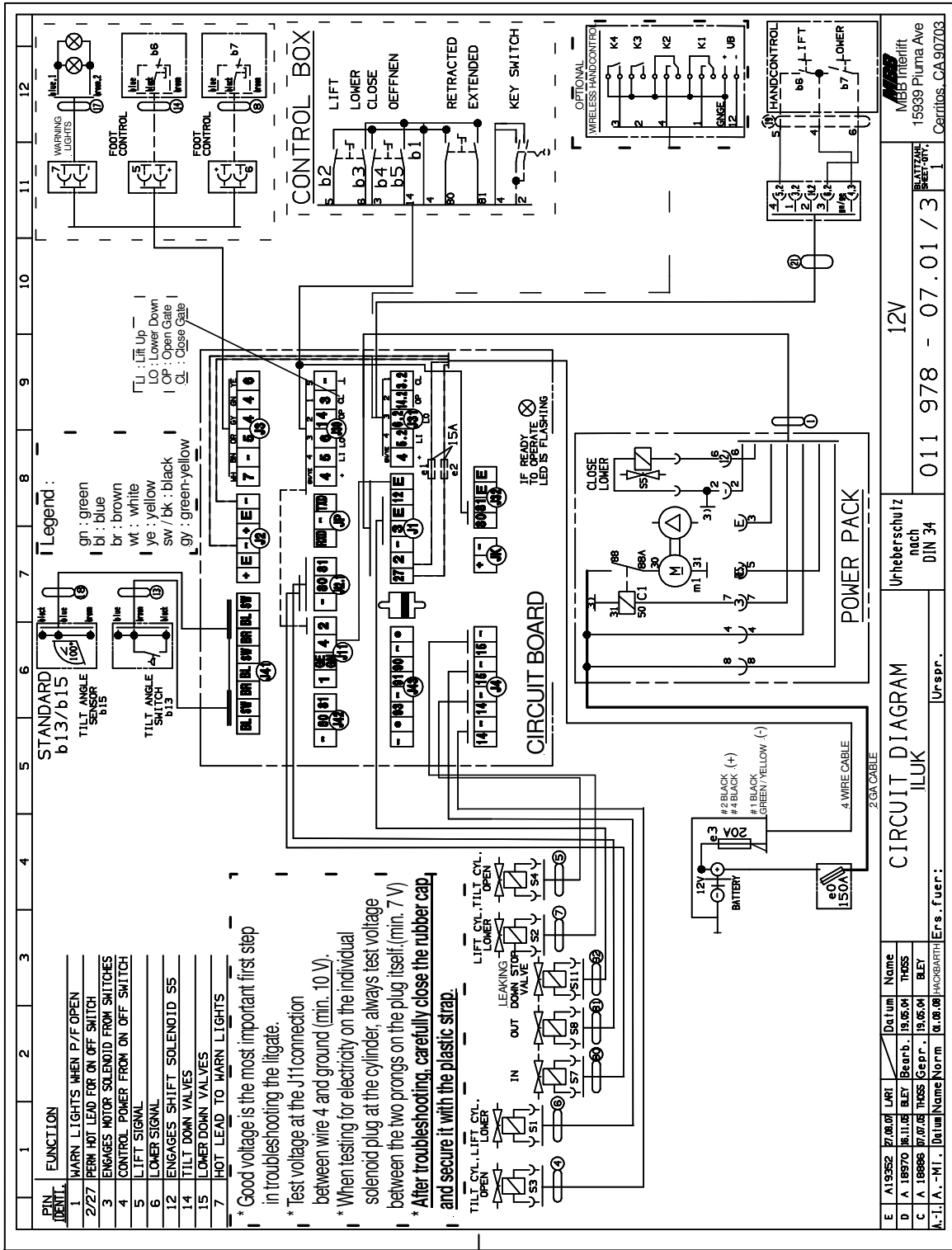

Figure 8: Main Wiring

⚠ FOLLOW DOTTED LINE IF ISOLATOR OR AUXILLIARY BATTERIES INSTALLED!

7.2.2 Electrical Schematic



7.2.3 Connector Overview

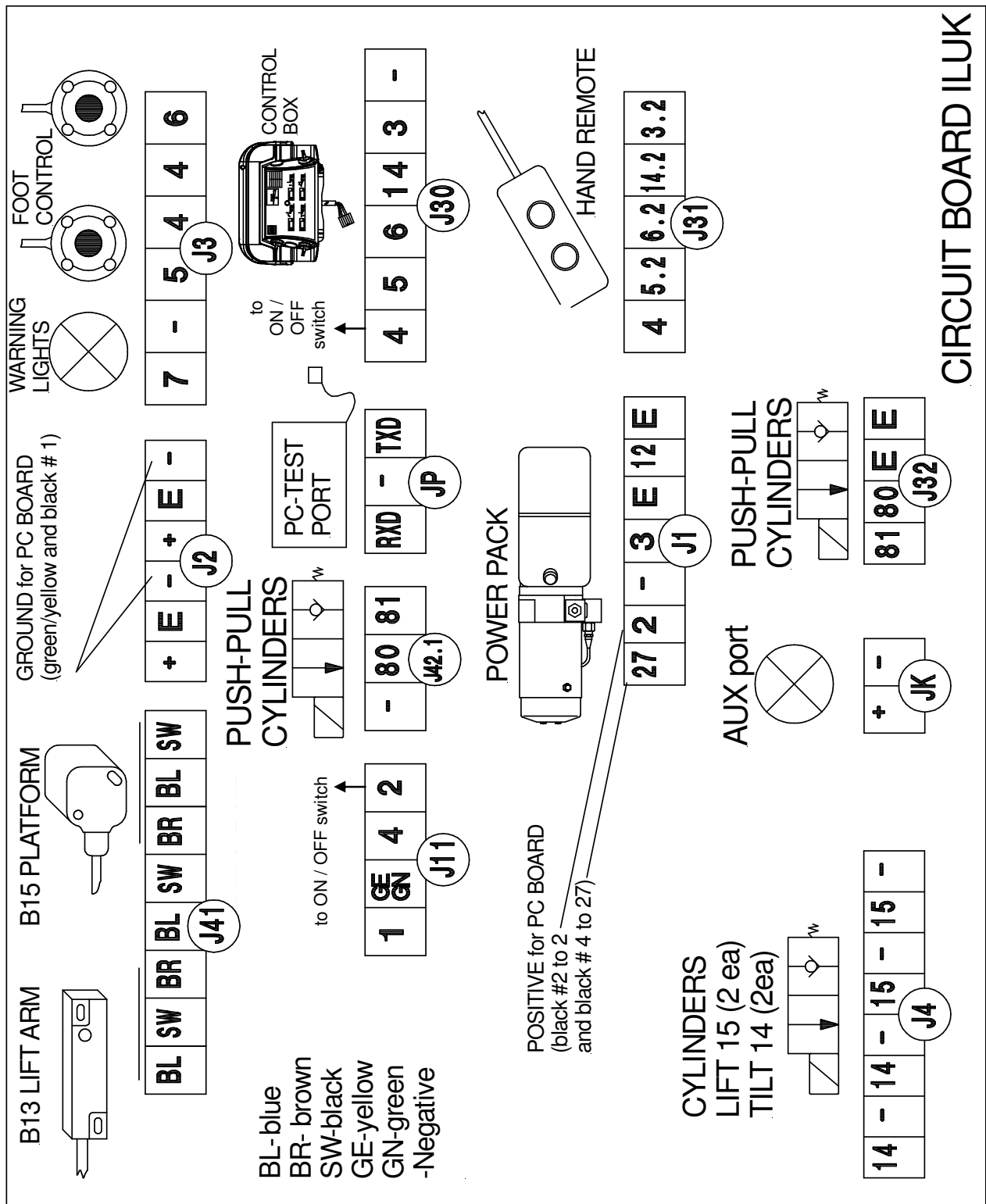

Figure 10: Connector Overview

7.2.4 Hydraulic Schematic

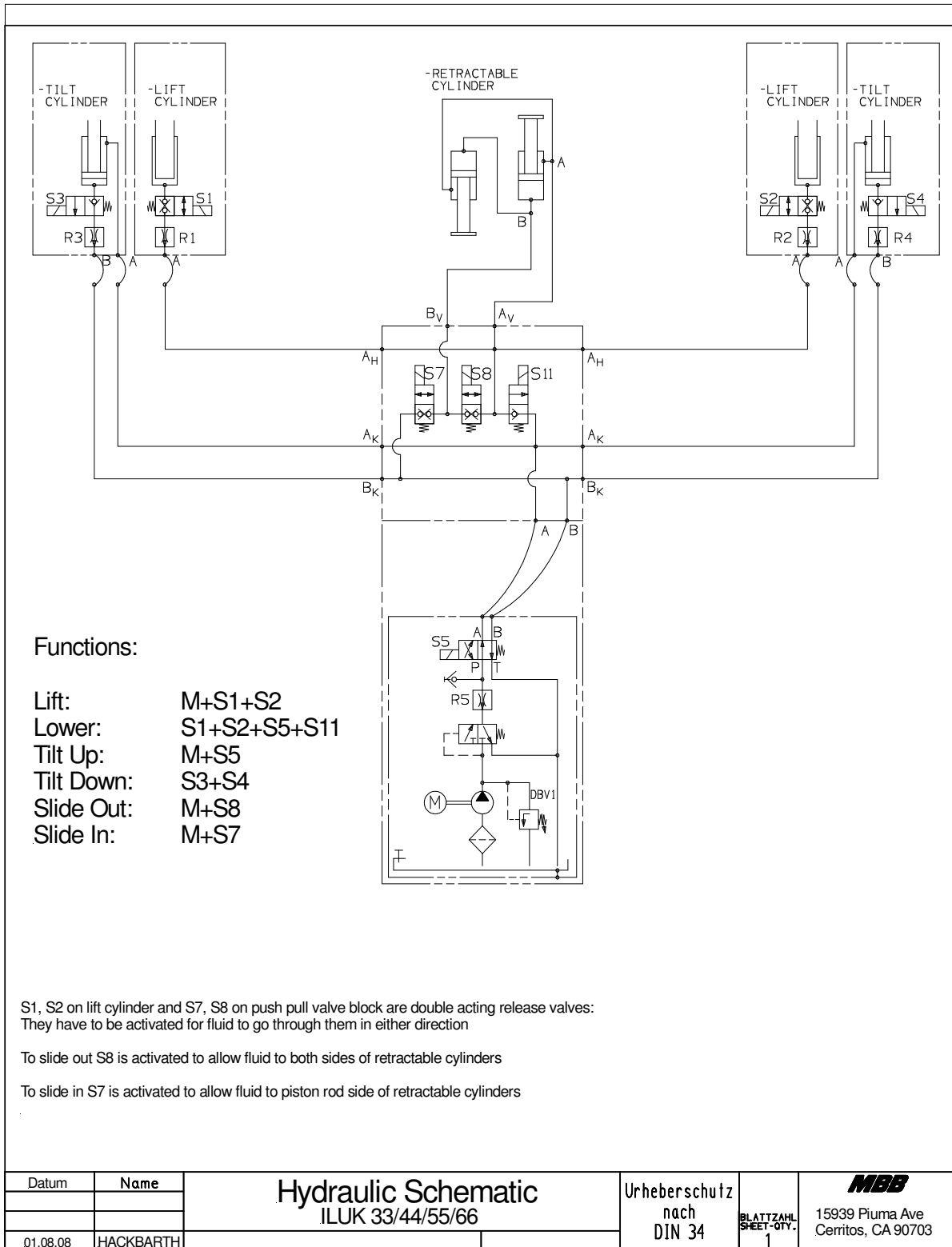

Figure 11: Hydraulic Schematic

7.3 Functional Description of Hydraulics when Operating

The description in the following chapters are relating to Figure 11 “Hydraulic Schematic”. Please use this drawing to understand the specific functionality of the ILLUK lift gate.

7.3.1 Slide Out Function

- As soon as the Motor starts to run, valve S8 is energized.
- Oil pressure on input “A” sets exits “Av” and Bv” at the valve block under pressure.
- The surface at the end of the piston rod on input “B” is larger than on the shaft at input “A”.
- This creates a stronger force at the piston rod (“B”) than at the shaft (“A”).
- This factor forces the cylinder to extend.
- The lift gate will slide out to the end of the rails.

7.3.2 Lower Down and Auto Tilt Function

- The shift valve S5 at the pump and the solenoid release valves S1 and S2 at the cylinders will get energized. In addition the leaking down stop valve S11 in the back of the mount frame is also energized.
- The gate is designed to lower down by gravity. It will push the hydraulic oil out of the lift cylinder into the reservoir. The oil passes the solenoid release valves S1 and S2. It also has to pass the energized S11 valve in the back of the mount frame and the shift valve S5 at the pump.
- When the platform touches the ground the auto tilt function will get activated (B-13).
- Solenoid release valves S3 and S4 at the tilt cylinders will be activated.
- The existing oil in the tilt cylinder runs back through the energized solenoid release valves S3 and S4 and the energized shift valve S5.
- Speed of tilting down will be reduced by passing through the restrictor R5.

7.3.3 Level Out Activity

- Motor starts running and S5 valve is energized.
- Oil pressure on input “B” sets pressure on exits “BK” at the valve block.
- The Oil pressure on exit “BK” at the valve block sets the input “B” at the tilt cylinder on pressure.
- The platform will tilt up and get in a level position. When the platform is leveled, the B-15 Platform sensor shuts down the shift valve S5 and activates the S1 and S2 valves at the Lift Cylinders which directs the fluid into the Lift Cylinders. This causes the platform to raise.

7.3.4 Lift Up Function

- Motor starts running and double locking release valves S1 and S2 are energized.
- The pressure is on input “A” at the valve block. The oil passes the S11 valve and sets pressure on exit “AH”.
- The energized double locking release valves S1 and S2 forces the fluid to push the lift cylinders to extend. The platform raises up.

7.3.5 Slide In Function

- Motor starts running and S7 valve is energized.
- Oil pressure on input “A” sets pressure on exits “Av” at the valve block.
- The Oil pressure on exit “Av” at the valve block sets pressure on input “A” at the cylinder.
- The energized valve S7 is allowing the oil at the bottom of the piston rod to get back through the S5 into the reservoir.
- The pressure on the end of the shaft will force the piston rod to retract.
- The liftgate will slide in under the body.

7.4 ILUK Push-Pull Valving

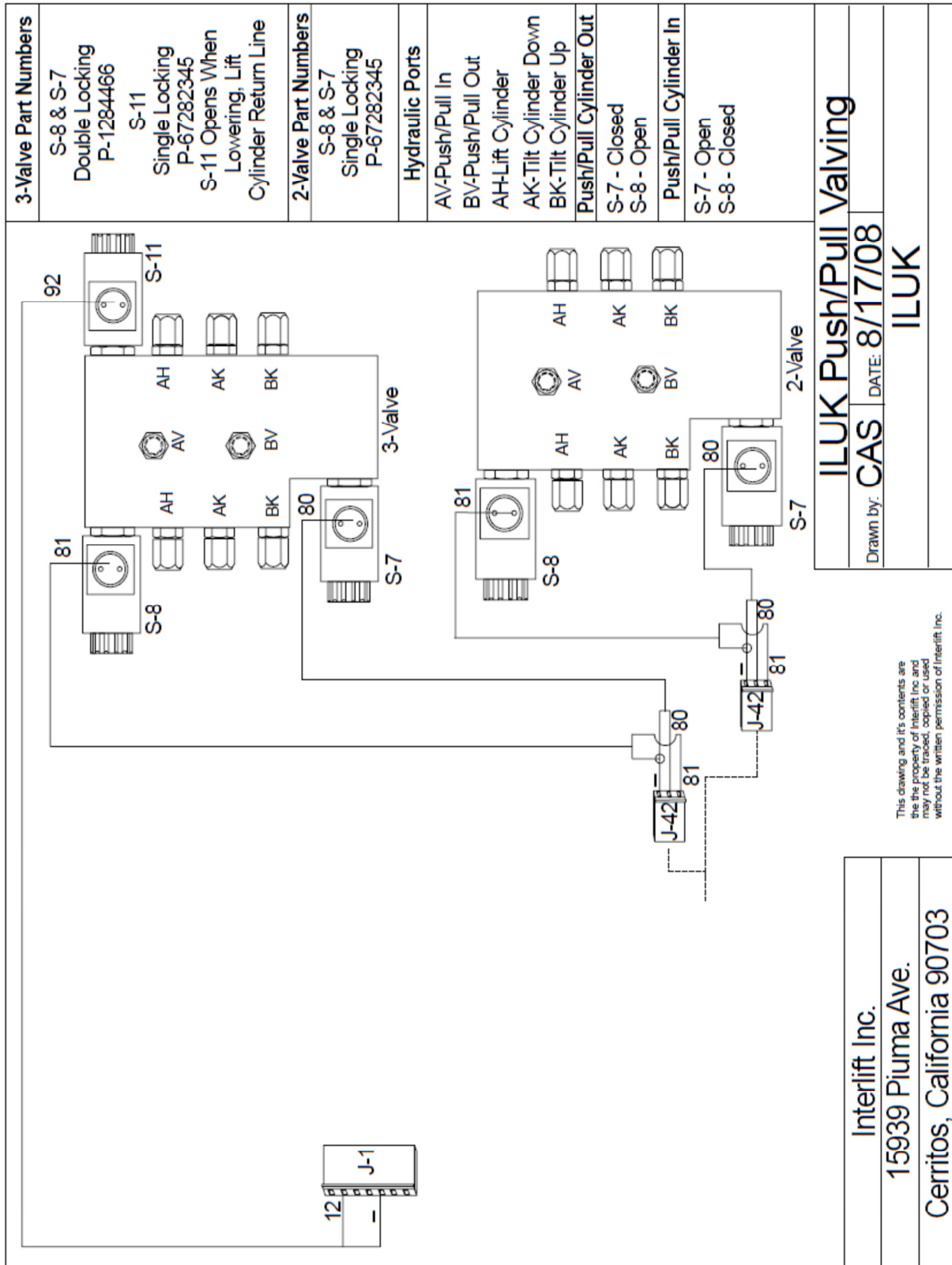

8. Needed Information for Ordering Spare Parts and Repairs

8.1 Ordering Spare Parts

In order to assure quick delivery of spare parts, please always state the following information when making orders:

1. Liftgate model & serial number.
2. Designation and number of the spare part in accordance with the spare parts list.
3. Designation and number marked on the individual component (if available).

8.2 Repairs

Parts sent to PALFINGER Liftgates to repair must be accompanied by a letter (in separate cover) giving details and scope of the repairs required.

9. Warranty

PALFINGER Liftgates provides warranty as part of its conditions of delivery.

Spare part deliveries are first of all billed. PALFINGER Liftgates then issues credit for all or part of the invoiced sum, when PALFINGER Liftgates has been able to determine that the warranty claim is justified as defined by its warranty conditions. PALFINGER Liftgates does this by inspecting the defected parts which are sent back to PALFINGER Liftgates freight-prepaid as well as the written description of the problem which must have been filled out in full.

The parts that are sent back to PALFINGER Liftgates, marked with serial number and address, become PALFINGER Liftgates' property if the warranty claim is accepted.

All warranty claims must be received **within 30 days** of repair or replacement. Including the following information:

1. Liftgate model.
2. Liftgate serial number.
3. Description of problem.
4. Itemized bill of repair with break down of number of hours to perform warranty work and labor charges per repair.
5. Parts used for repair with PALFINGER Liftgates part number.
6. RMA#.
7. Contact at PALFINGER Liftgates, if applicable.

Model	Pump and Motor	Cylinders	Hardware	Control System	Hydraulic
ILUK Under Slider	2 yr	3 yr	2 yr	2 yr	2 yr

Table 3: Warranty Coverage Schedule¹

¹ Effective: Aug. 2010

10. **Contact Address**

PALFINGER Liftgates, LLC.

15939 Piuma Ave
Cerritos, CA 90703

Phone: (562)-924-8218

Fax: (562)-924-8318

E-mail (parts order): customerservice@PALFINGER.com

E-mail (technical support): technicalservice@PALFINGER.com

PALFINGER Liftgates, LLC.

572 Whitehead Road
Trenton, NJ 08619

Phone: (609)-587-4200

Fax: (609)-587-4201

E-mail (parts order): customerservice@PALFINGER.com

E-mail (technical support): technicalservice@PALFINGER.com