



**LIFTGATES**

---

**ILSL 33/44**

**OWNER'S MANUAL**

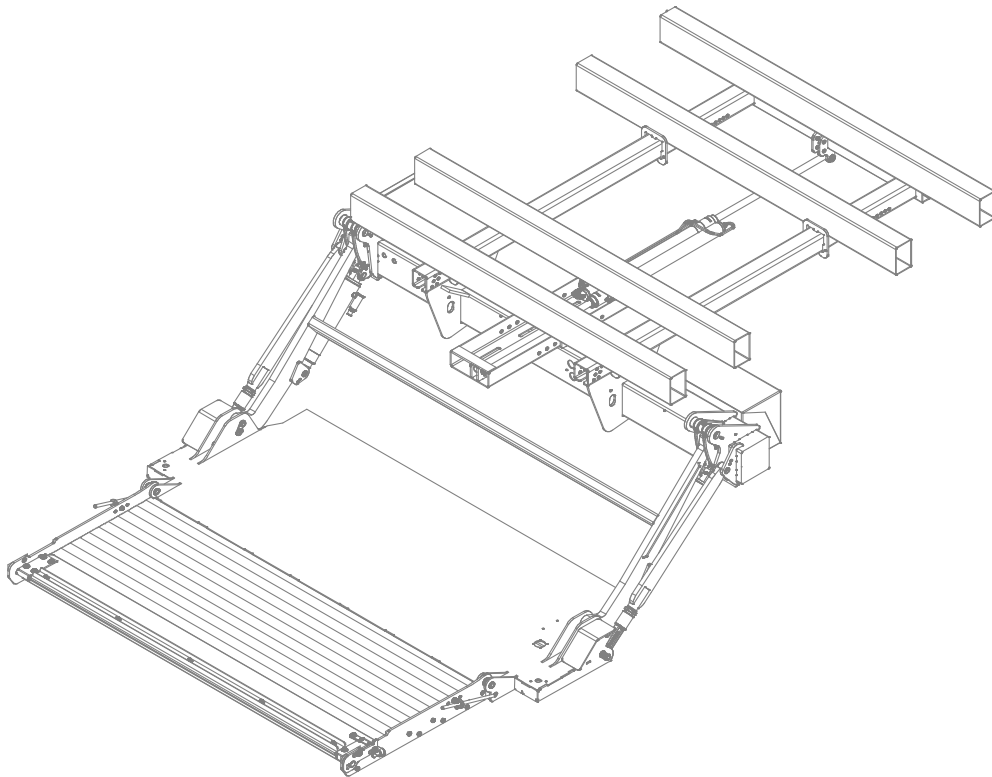

**ILSL 33/44 Owner's Manual**

**Document Part Number: 90-1614-002, 14-686\_90-00\_00-02**

**ECN-M0608, Rev. 1.2, 06-10-15**

**Copyright © 2015 Palfinger Liftgates LLC.**

**All rights reserved.**

**Information in this document is subject to change without notice.**

**Visit [www.palfinger.com](http://www.palfinger.com) for up to date information and notifications.**

**If you received this product with damaged or missing parts,  
contact Palfinger Liftgates at (888)-774-5844**

**Parts Order**

**[liftgateparts@palfinger.com](mailto:liftgateparts@palfinger.com)**

**Technical Support**

**[technicalapplications@palfinger.com](mailto:technicalapplications@palfinger.com)**

**PALFINGER Liftgates, LLC.**

**15939 Piuma Ave.**

**Cerritos, CA 90703**

**Tel (888)-774-5844**

**Fax (562)-924-8318**

**PALFINGER Liftgates, LLC.**

**572 Whitehead Road.**

**Trenton, NJ 08619**

**Tel (609)-587-4200**

**Fax (609)-587-4201**

## Table of Contents

<b>1</b>	<b>Important Notes .....</b>	<b>5</b>
1.1	Attention .....	5
1.2	Important Notes .....	5
1.3	General Information .....	6
<b>2</b>	<b>Safety Information .....</b>	<b>8</b>
<b>3</b>	<b>General View of Liftgate .....</b>	<b>9</b>
3.1	ILSL Liftgate Overview .....	9
<b>4</b>	<b>Maximum Load and Placing of Load on Platform .....</b>	<b>10</b>
<b>5</b>	<b>Operation of Liftgate .....</b>	<b>12</b>
5.1	Operation by Control Box/Hand Control .....	12
5.2	Operation by Foot Control (Optional) .....	15
5.3	Toggle Switch/Switches (Optional).....	15
5.4	3-Button Flush Mount Control, Vertical Mount (Optional) .....	16
5.5	3-Button Flush Mount Control, Horizontal Mount (Optional) .....	17
5.6	6-Way Wireless Remote (Optiona).....	18
<b>6</b>	<b>Preventive Maintenance and Quick Check .....</b>	<b>19</b>
6.1	Maintenance and Care.....	19
6.2	Lubrication .....	20
6.3	Checking and Changing the Oil.....	21
6.3.1	Recommended Hydraulic Fluids.....	21
6.4	Decal Placement and Inspection.....	22
6.5	Quick Check List .....	24
<b>7</b>	<b>Troubleshooting .....</b>	<b>25</b>
7.1	Liftgate will not power on.....	25
7.2	ON/OFF switch is ON but all functions are dead .....	28
7.3	Electrical Wiring .....	29
7.4	Cross Test on Single Pole Plug Charge System .....	32
7.5	Electrical Schematic.....	33
7.6	Control Board Connector Overview.....	34
7.7	Hydraulic Schematics.....	35
7.7.1	Hydraulic Schematic.....	35
7.7.2	Slide Out Function.....	36

---

7.7.3	Lower Down .....	36
7.7.4	Lift Up Function .....	36
7.7.5	Slide In Function.....	36
7.8	Hydraulic Schematic (Discontinued).....	37
7.8.1	Slide Out Function.....	38
7.8.2	Lower Down .....	38
7.8.3	Lift Up Function .....	38
7.8.4	Slide In Function.....	38
7.8.5	Push-Pull Valving (Discontinued) .....	39
<b>8</b>	<b>Needed Information for Ordering Spare Parts and Repairs.....</b>	<b>40</b>
8.1	Ordering Spare Parts .....	40
8.2	Repairs .....	40
<b>9</b>	<b>Warranty.....</b>	<b>40</b>
<b>10</b>	<b>Contact Address.....</b>	<b>41</b>

**Company Information:**

**Company Name:** \_\_\_\_\_

**Advisor Name:** \_\_\_\_\_

**Trailer Year Make & Model:** \_\_\_\_\_

**Liftgate Information:**

**Liftgate Serial Number:** \_\_\_\_\_

**Liftgate Model Number:** \_\_\_\_\_

**Date of Purchase:** \_\_\_\_\_

**Date of Installation:** \_\_\_\_\_

## 1 Important Notes

### 1.1 Attention

Before starting any operations of the liftgate, please read and understand this OWNER'S MANUAL. It is intended to act as a guide for the operation personal as well as to give help with preventive maintenance but does not take place of unauthorized usage or repair by unqualified personnel.

Please contact your nearest PALFINGER Liftgates distributor or PALFINGER Liftgates in California or New Jersey for assistance if you have questions regarding installation, operation or maintenance.

This owner's manual applies to the following models: **ILSL 33, 44**



This is the safety alert symbol. It is used to alert you to potential personal injury hazards. Obey all safety messages that follow this symbol to avoid possible injury.

### 1.2 Important Notes

The PALFINGER Liftgates ILSL model is an electro-hydraulically driven lift gate, designed to be stored underneath the trailer for ultimate dock loading as well as offering up to 6-1/2 feet platform.

The Hydraulic Power Unit (HPU) is easily accessible for service and exchange.

The platform folded in half is supported by two torsion springs, each on one side, one support folding the other unfolding operation. Lifting actions are carried out by hydraulic cylinders mounted on the lift arms.

The gate is equipped with swing fixtures mounted to the bottom on each lift cylinder. This enables the platform to lower down the tip towards the ground. The hydraulic cylinders are equipped with solenoid operated valves located at the port of each cylinder which prevents the platform from lowering accidentally unless the operator is activating the controls. This system also enables you to store the lift gate without a separate platform latch.

The piston rods are treated against corrosion. The HPU is equipped with a built-in pressure relief valve, which prevents overloading when lifting.



**The valves do not prevent overloading of the platform when lowering or tilting down.**



The electric supply is taken from the auxiliary batteries. The electric control power is protected via a 20 Amp fuse and an on-off switch. Trailer application has an on-off switch located in the lockable control box. The liftgate is operated from an outside control box which is located on the curbside of body. Foot controls are optional, which enables the operator to handle the cargo and operate the liftgate by foot. A variety of different product options can be purchased with the liftgate as well.

## 1.3 General Information

### REMEMBER!

It is the fleet manager's responsibility to educate the operator on the liftgate and its intended use. The operator's attention should be drawn to the permitted load limits and an understanding of the operation to ensure the safety throughout the operation.

### ONE-MAN OPERATION!

Never let an "outsider" operate the liftgate while you are handling the cargo. A "misunderstanding" can result in serious personal injury or even death.



In the interest of safety it is important that all operating personnel properly understand the functions of the liftgate, possible hazards, dangers, the load limits and load positioning for that specific unit.

### IMPORTANT NOTICE!



Before the operator uses the liftgate, they should be thoroughly familiar with the lift's functions and usage according to the following:

1. Improper operation of this lift can result in serious personal injury. Do not operate unless you have been properly instructed, have read and are familiar with the operation instructions. If you do not have a copy of the instructions please obtain them from your employer, distributor or lessor, as appropriate, before you attempt to operate the lift.
2. Be certain the vehicle is properly and securely stopped before using the lift.
3. Always maintain the liftgate and inspect it for damage before usage. If there are signs of improper maintenance, damage to vital parts, or slippery platform surface, do not use the lift. Do not attempt your own repairs unless you are specifically trained.
4. Do not overload. See the Rating Label on the unit for the rated load. Remember that this limit applies to both raising and lowering operations.
5. Each load should be placed in a stable position as near as possible to the body of the trailer.
6. Never stand in, move through or allow anyone else to stand in or move through the area in which the lift operates, including that area in which a load might fall.
7. This is not a passenger lift. Do not ride the lift with unstable loads or in such a manner that a failure would endanger you. The lift is not equipped with a back-up system to prevent falling cargo in the event of a failure.

**The maximum loads must be observed and followed!**



**IMPROPER USE**



It is not permitted to use the tail lift:

- As an elevating work platform.
- To push loads.
- To carry people (Only the operator may travel on the platform).
- To clear snow.

Please read through the operational and technical description of the PALFINGER Liftgates Liftgate.

## 2 Safety Information

This manual follows the Guidelines set forth in ANSI X535.4-2007 for alerting you to possible hazards and their potential severity.



**! DANGER** indicates an imminently hazardous situation which, if not avoided, **will result** in death or serious injury.



**! WARNING** indicates potentially hazardous situation which, if not avoided, **could result** in death or serious injury.



**! CAUTION** indicates a potentially hazardous situation which, if not avoided, **may result** in minor or moderate injury.



**CAUTION** without the safety alert symbol is used to address practices not related to personal injury. *(In this manual we use it to alert you to potentially hazardous situation which, if not avoided, may result in property damage.)*



**NOTICE** without the safety alert symbol is used to address practices not related to personal injury. *(In this manual we use it to alert you to special instructions, steps, or procedures.)*



Improper operation of this liftgate may result in severe personal injury or death. **DO NOT** operate unless you have been properly instructed, have read and are familiar with the procedures in this manual. We have designed this manual to illustrate the steps needed for the basic operation of this ILSL liftgate. It also provides safety information and simple preventive maintenance tips.



### 3 General View of Liftgate

#### 3.1 ILSL Liftgate Overview

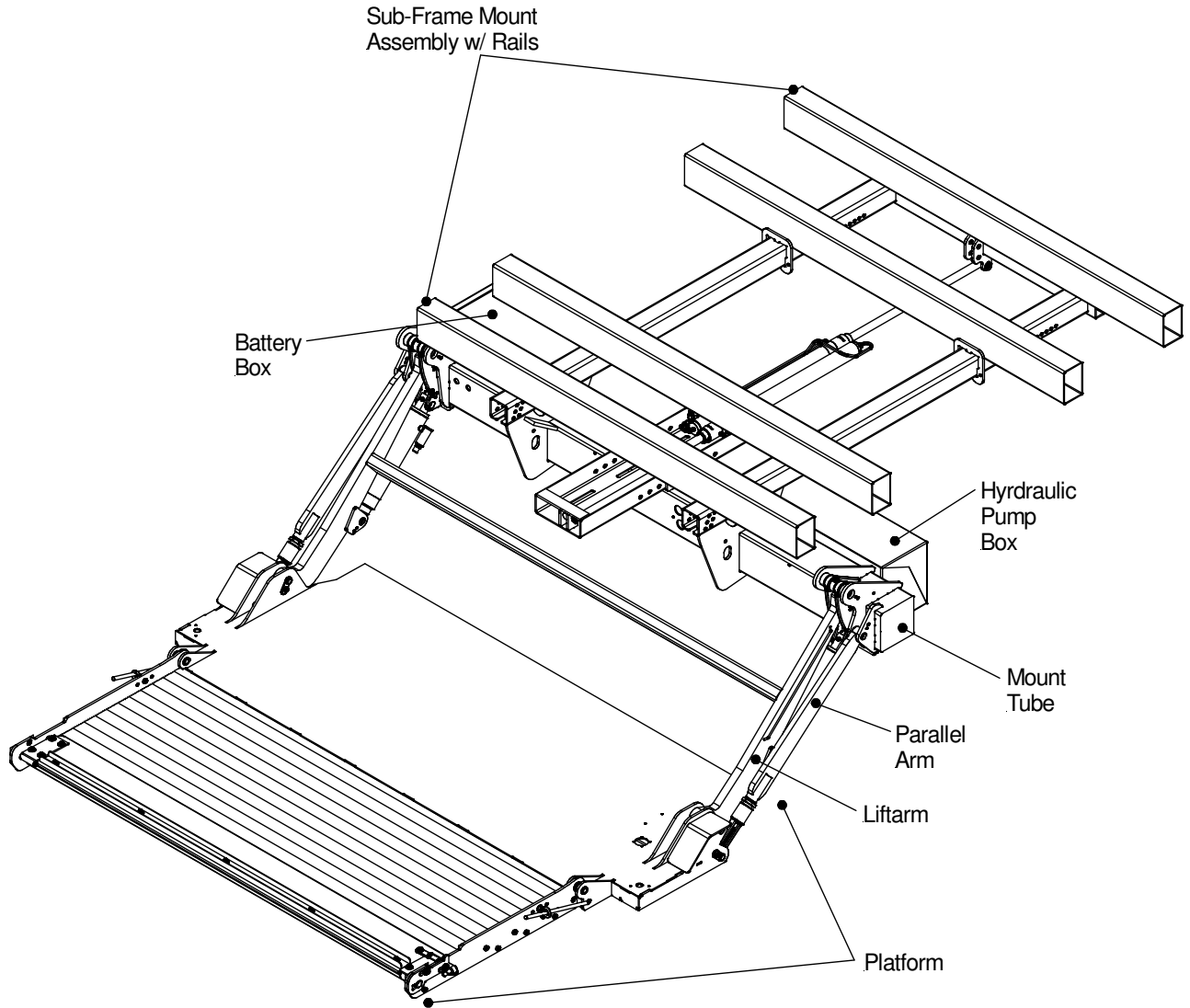

*ILSL Liftgate Overview*

## 4 Maximum Load and Placing of Load on Platform

Every Palfinger liftgate is rated up to a maximum load. The point of maximum load is rated at a defined distance. The center point of maximum load is at 24" from the outside of the trailer body to center of load.

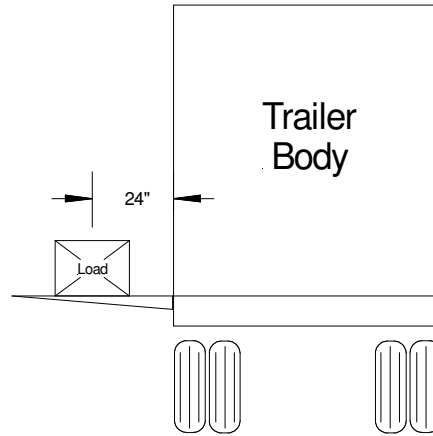

**Center Point of Load**



By increasing this distance the maximum load of the lift gate is decreasing.

An overview about the rating depending, on the distance from the end of the platform is shown in the following load diagram.

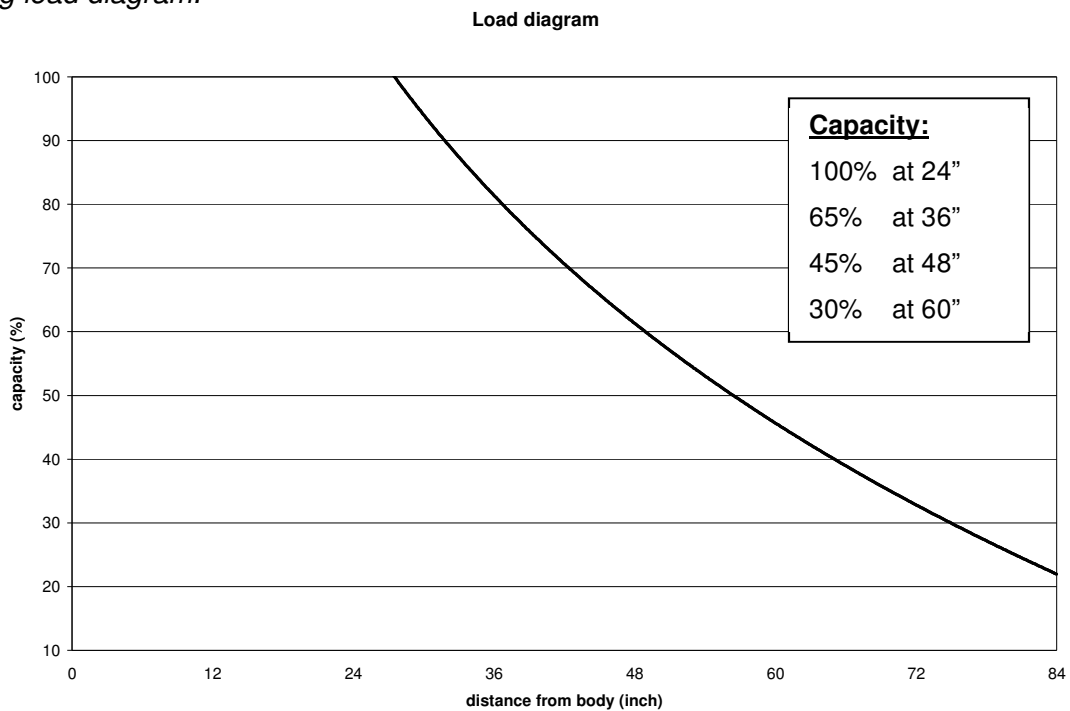

*Load Diagram*

NOTES

## 5 Operation of Liftgate

### 5.1 Operation by Control Box/Hand Control



**NOTE:** Never slide platform in or out with load on the platform

1. Power the liftgate by turning the ON/OFF switch down.

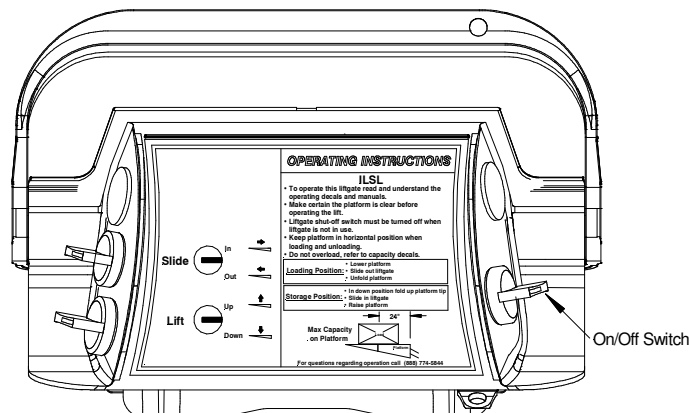

2. Rotate the **Lift** button **Down** to lower the platform enough that it clears the platform storage upstops.

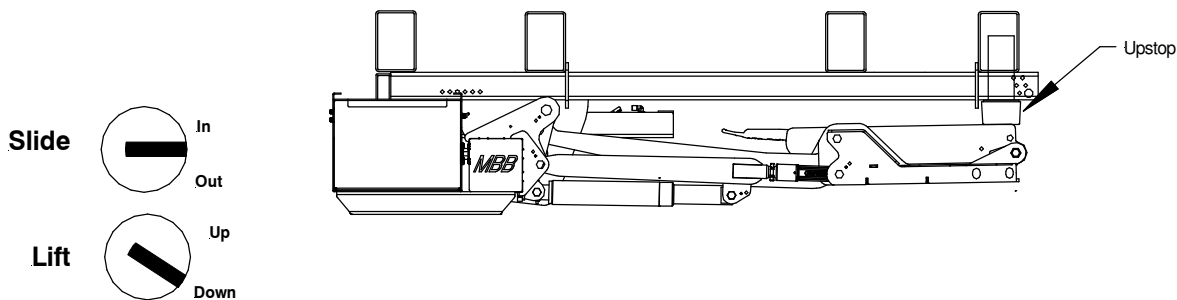

3. Use the **Slide** button **Out** to slide the gate out from its stored position until it meets the stop bolt at the front of the slide rail.

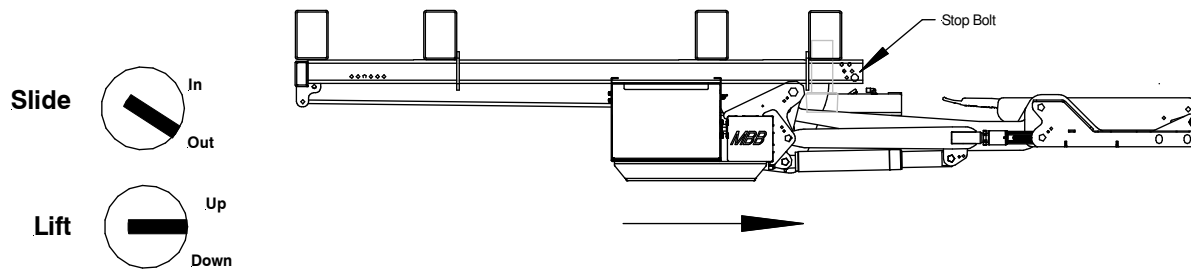

- Use the **Lift** button **Down** to lower the platform to about 3" off the ground. Unfold the platform tip manually by using the straps. Use **Lift** button **Down** again to lower platform to the floor.

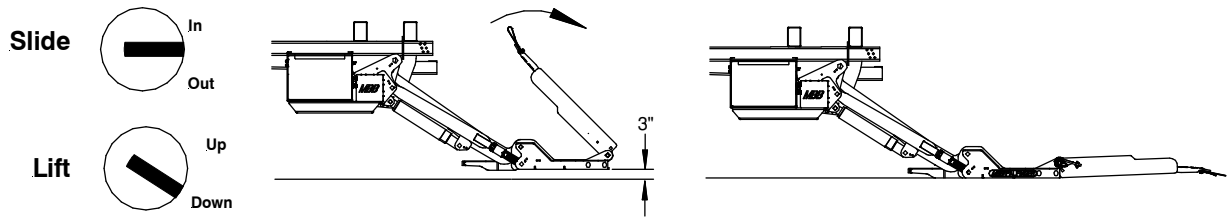

- Load the platform. Center the load 24" away from the outside of the trailer body.

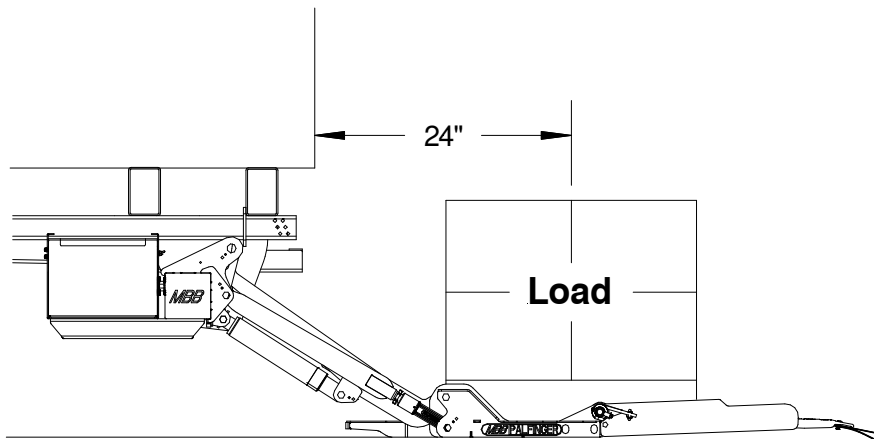

- At this point of operation, the operator must use the 2-Button Hand Held Remote (HHR) to lift the platform/load up and down. Toggle switches and Foot Controls may also be used if these options have been installed. If using the Toggle Switch or Foot Controls, see pages 13 for operating instructions.

- Press and hold the Top (white) button on the 2-Button Hand Held (HHR) Control to raise the platform/cargo. Place the control on the holster while removing the cargo from the platform. Press and hold the Bottom (black) button to lower the platform back to the ground. **REMINDER: Do not store HHR inside refrigerated bodies.**

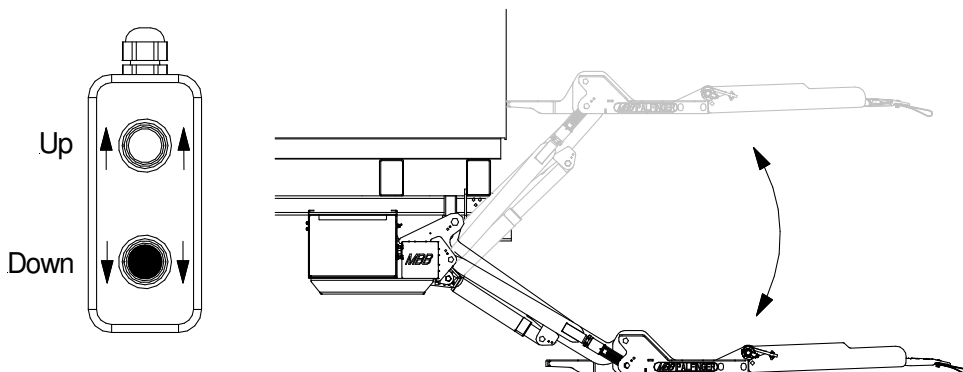

**To Store Liftgate**

1. When platform is on the ground, use the **Lift** button **Up** to get the platform 3" off from the ground. Manually fold the tip of the platform.

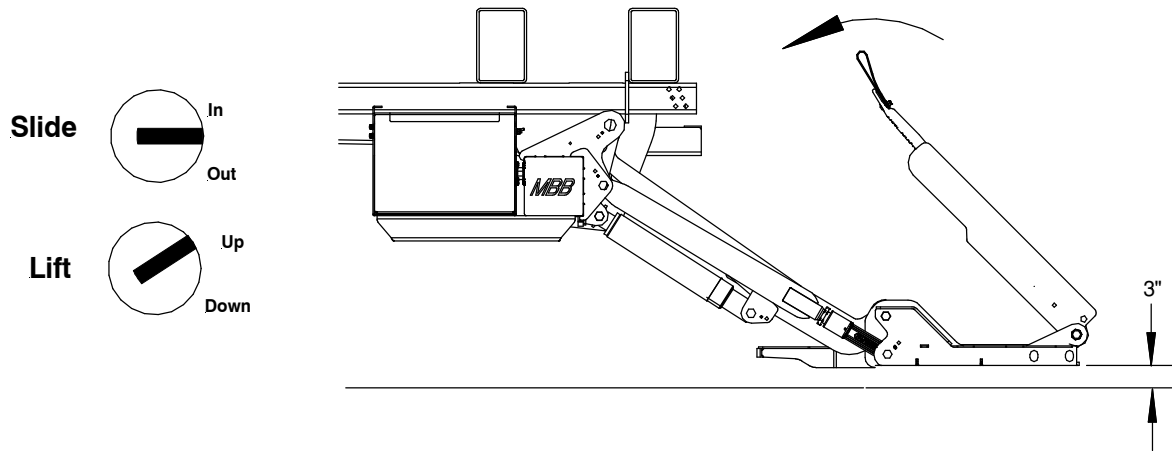

2. Use the **Slide** button **In** until the sliding plates hit the stop bolt in the rear of the sliding rail.

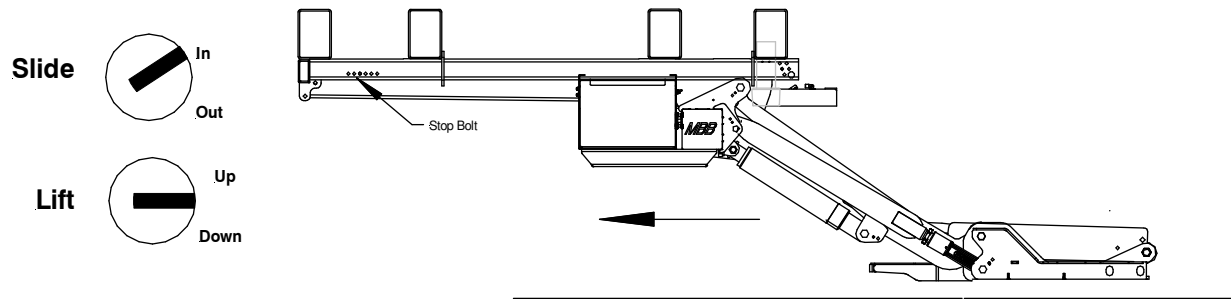

3. When the sliding plates have stopped and reached the stop bolt in the rear, use the **Lift** button **Up** to secure the platform flush with the upstops until the upstop is compress 1/2" and release the button.

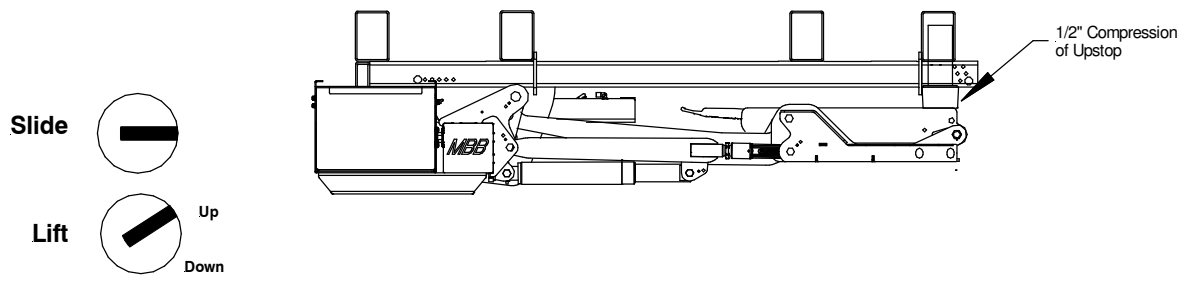

## 5.2 Operation by Foot Control (Optional)

### Lower Platform:

Step on the front foot control and hold, wait three seconds before stepping on the rear foot control.

### Raise Platform:

Step on the rear foot control and hold, wait three seconds before stepping on the front foot control.

*If the platform is not responding to the controls within three seconds, repeat steps above.*

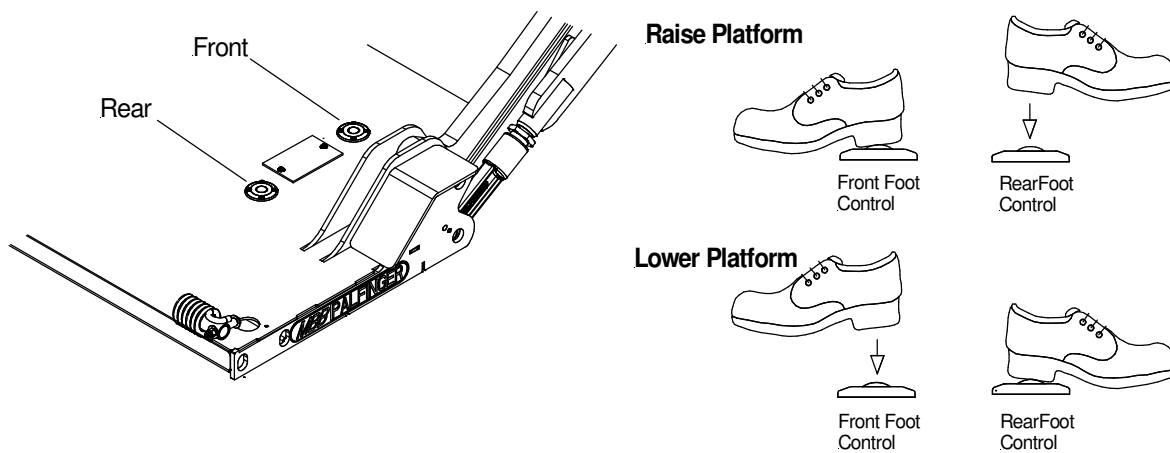

## 5.3 Toggle Switch/Switches (Optional)

1. Toggles switches are an alternative to the 2-Button HHR Control.
2. Toggles switches only raise the platform up and down.

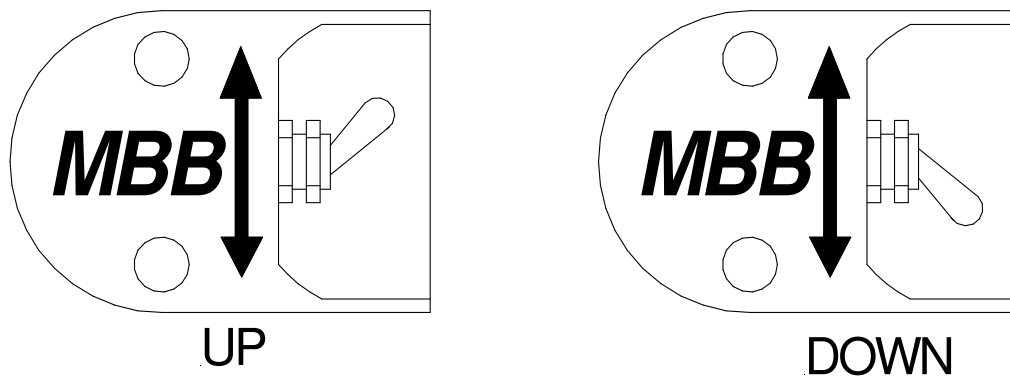

### 5.4 3-Button Flush Mount Control, Vertical Mount (Optional)

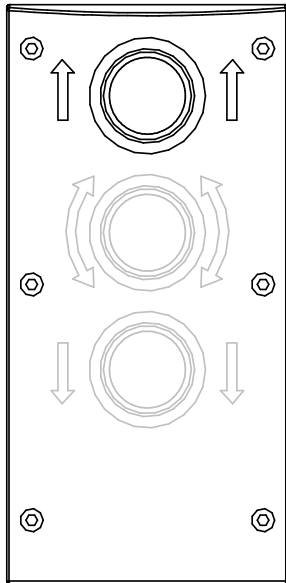

**Raise Platform**  
Push and hold **Top** button

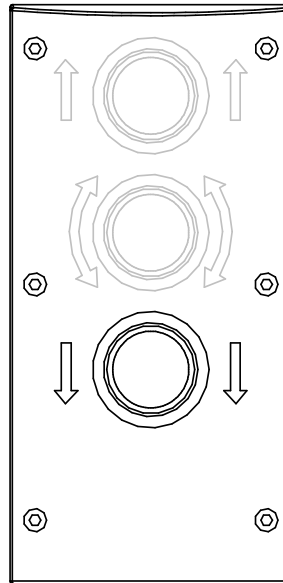

**Lower Platform**  
Push and hold the **Bottom** button

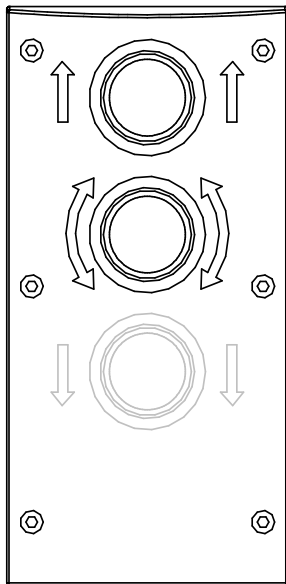

**Slide In Platform**  
Push and hold the **Top** and **Middle** buttons simultaneously

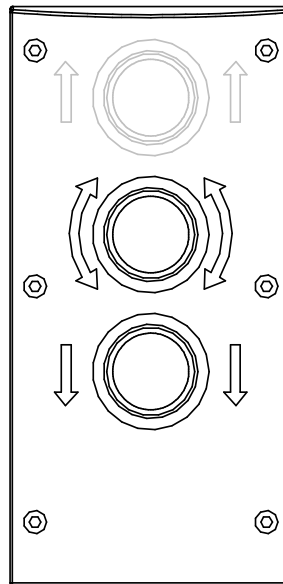

**Slide Out Platform**  
Push and hold the **Bottom** and **Middle** buttons simultaneously



### 5.5 3-Button Flush Mount Control, Horizontal Mount (Optional)

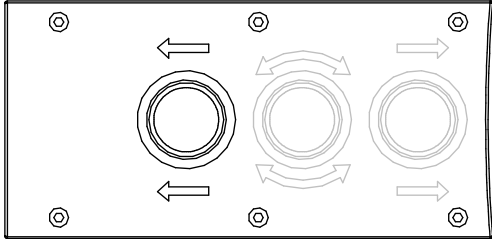

**Lower Platform**  
Push and hold the **Bottom** button

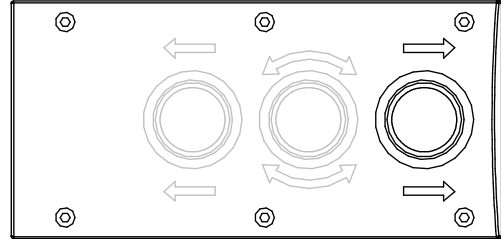

**Raise Platform**  
Push and hold **Top** button

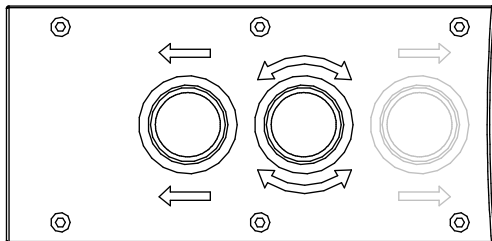

**Slide Out Platform**  
Push and hold the **Bottom and Middle** buttons simultaneously

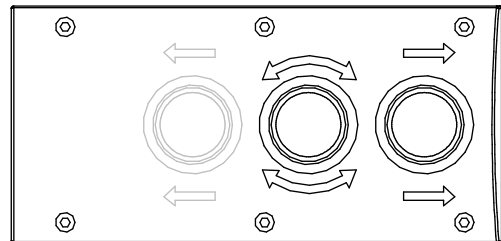

**Slide In Platform**  
Push and hold the **Top and Middle** buttons simultaneously

## 5.6 6-Way Wireless Remote (Optiona)

1. Power the remote control unit using the ON/OFF switch located on the rear side of the control
2. Reference illustration below for gate opertaion.

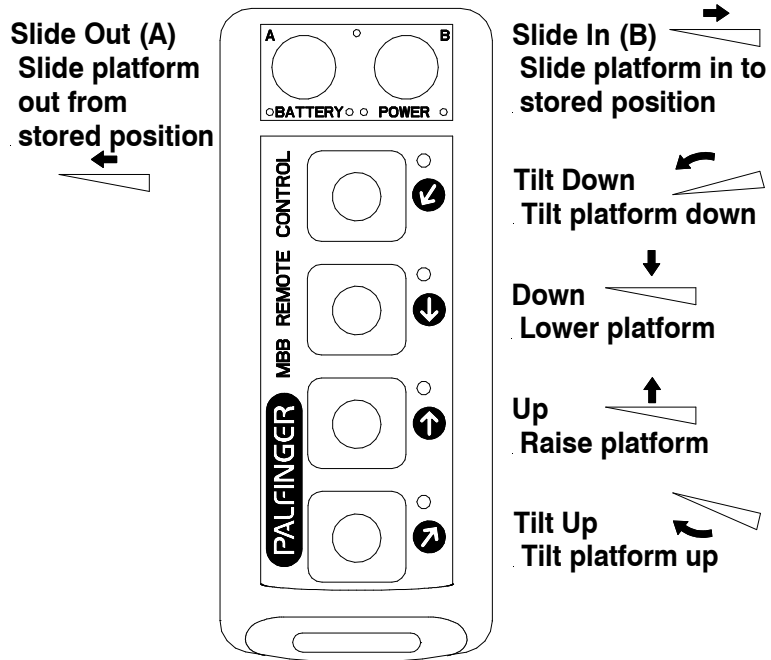

*6-Way Wireless Remote Control Unit*

## 6 Preventive Maintenance and Quick Check

The ILSL needs preventive maintenance to perform at its fullest capability. Lubricate and inspect regularly. Also, check on hoses, cables, controls, etc. and make sure these components are not damaged.



### REPAIR OR REPLACE IMMEDIATELY FAULTY PARTS



### 6.1 Maintenance and Care

The following “inspection and maintenance” should be performed at the recommended intervals depending on operation and amount of cycles or at the time when the unit shows any signs of damage or abuse. In order to prolong the liftgates longevity it is important to maintain and perform preventive care as indicated below.

* Recommended bases for inspection and maintenance	Depending on use	Daily	Monthly	Quarterly
Cleaning	x			
General lubrication of pins and bushings				x
Oil level inspection				x
Oil change	x			
Check hydraulic hoses and pipes for leaks				x
Check controls and connections				x
Check pins and pin retaining bolts			x	
Check batteries and connections				x
Check warning labels and other safety equipment for effectiveness and visibility		x		
Visual check for loose or missing parts and un-usual noise during operation		x		
Check lock bolts and pins for tightness				x
Check complete function of gate		x		
Check mounting brackets of lift gate to frame for cracks or damage visually		x		

Maintenance Schedule

## 6.2 Lubrication

Properly lubricated, the ILSL series PALFINGER Liftgates will ensure longevity. Lubricate the liftgate at the same time as the trailer. Grease more frequently if the liftgate is heavily used. The liftgate should be greased every 500 cycles (depending on use – estimated every 3 month).

**All bearing points must be lubricated in accordance with the maintenance intervals.**

*Reminder: Lubricate all points with the platform at ground level.*

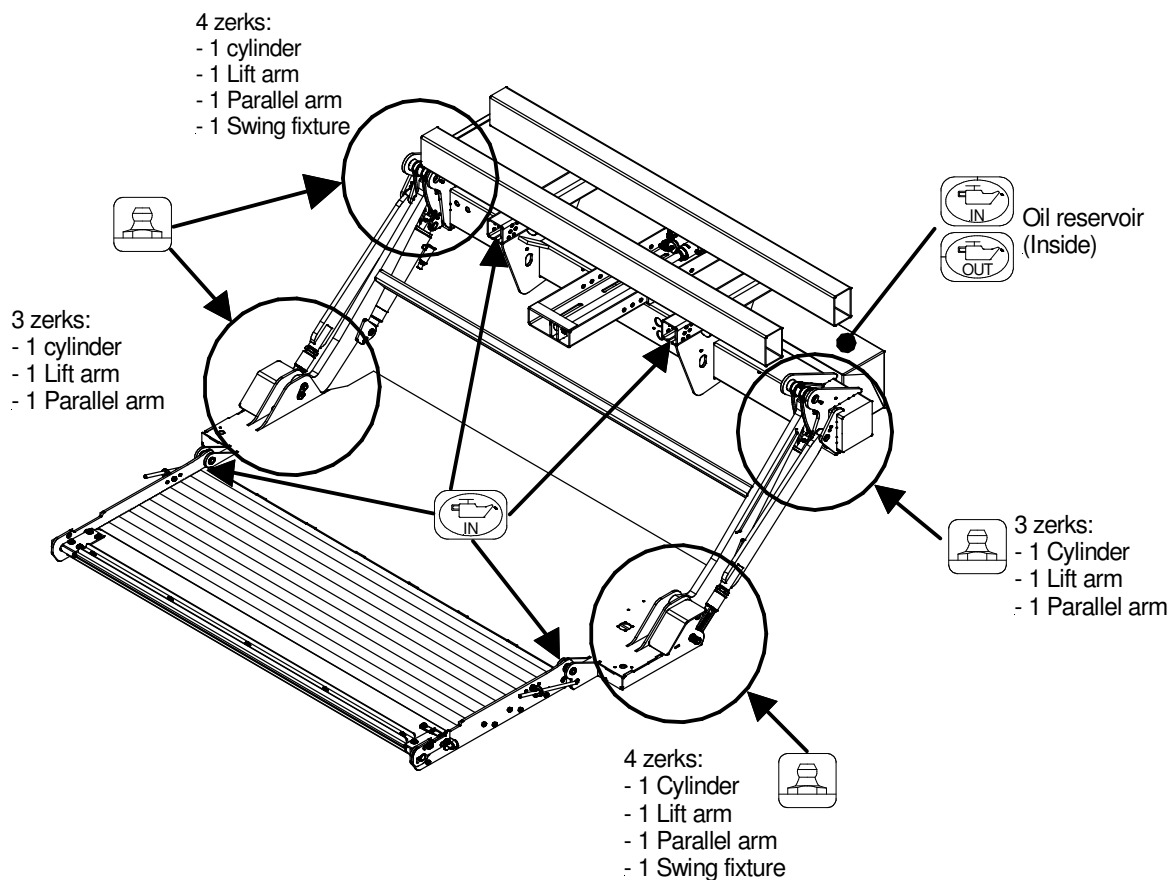

Grease – 12 places, (3 in the mount frame, 3 in the cylinder/platform area).



Oil level in the power pack tank (see marking inside of power pack reservoir).



Lubricate - Platform hinges and Cart Stops if present (use ZEP-45 spray for lubrication).

**NOTE:** Avoid using grease on rails to help prevent any mud and dirt build up.

### 6.3 Checking and Changing the Oil

Check the quality of the hydraulic fluid, the fluid should be free of contaminants such as debris, sludge, water, or air. All these factors can contribute to poor system performance and will reduce the life of the liftgate and liftgate components. If the fluid appears to be in poor condition, take the following steps to change the oil.

1. Lower gate to ground.
2. Remove the cover from the pump and motor box and locate the oil drainage bolt (6mm hex bolt) located at the bottom of the tray and let the fluid drain out of the reservoir and into an approved container. Screw the oil drainage bolt back.
3. Unscrew the oil filler cap. Use a good quality fluid based on your location; refer to the recommended fluids table. The fluid level should be between marks 5 and 7 when the platform is at ground level.
4. Change oil at least once a year, preferably in the fall before the weather gets cold.

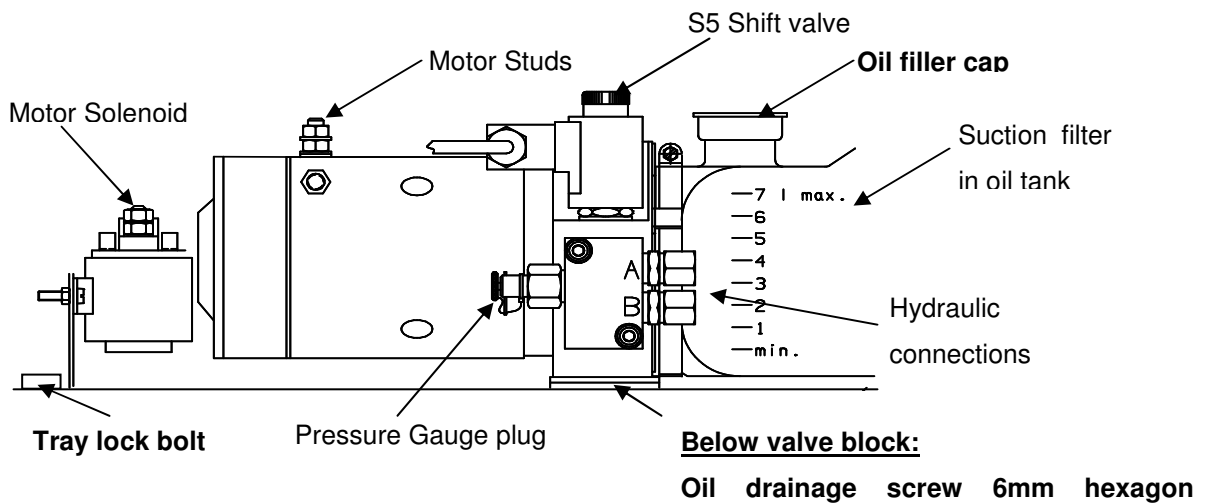

#### 6.3.1 Recommended Hydraulic Fluids

<u>TEMP. RANGE</u>	<u>BRAND</u>	
-10 TO 150 F	EXXON	UNIVIS J26
	MOBIL OIL	DTE 13M
	CHEVRON	AW MV32
	ROSEMEAD	MV 150 (32)
-50 TO 150 F	MOBIL	DTE 13M
	SHELL	AERO FLUID 4
<b>EXTREME COLD TEMPERATURE:</b>	<b>USE MILITARY SPEC:</b>	<b>MIL H5606</b>

## 6.4 Decal Placement and Inspection

For operator's safety, all decals appearing in "Decal Kit" must be in a conspicuous place on control side of liftgate to be read by operator. This is typically a combination of decals on the liftgate and truck body. Please make sure to place the maximum capacity decal on both sides of the door.

<b>Decal Kit</b>			
<b>Decal</b>	<b>Qty.</b>	<b>Part No.</b>	<b>Description</b>
A	1	ATG-URGWA	Urgent Warning: Elevating gate instructions
B	1	85-1614-000	Operating Instructions (Control Box)
C	1	ATG-SWILFP-V	3-Button Remote Control Vertical Mount (if applicable, must be located directly above control)
D	1	ATG-SWILFP-H	3-Button Remote Control Horizontal Mount (if applicable, must be located directly above control)
E	2	ATG-XXXX	Capacity (please check the serial number plate to find out your specific capacity)
F	1	ATG-CAB	Liftgate Shut-Off (located next to shut-off switch)
G	1	ATG-BKR	Max. Circuit Breaker Reset (must be located at the circuit breaker)
H	2	ATG-WLH	Warning: liftgate can crush
I	2	ATG-CTN	Caution: Always stand clear of platform area
J	1	ATG-RESET	Circuit Breaker Protection
K	1	ATG-FT	Notice for Foot Control (if applicable)
L	1	ATG-UD	Toggle Decal (next to the toggle switch, if applicable)
M	1	ATG-WNG	Warning: Use handle to open (must be located underneath handle (main section))

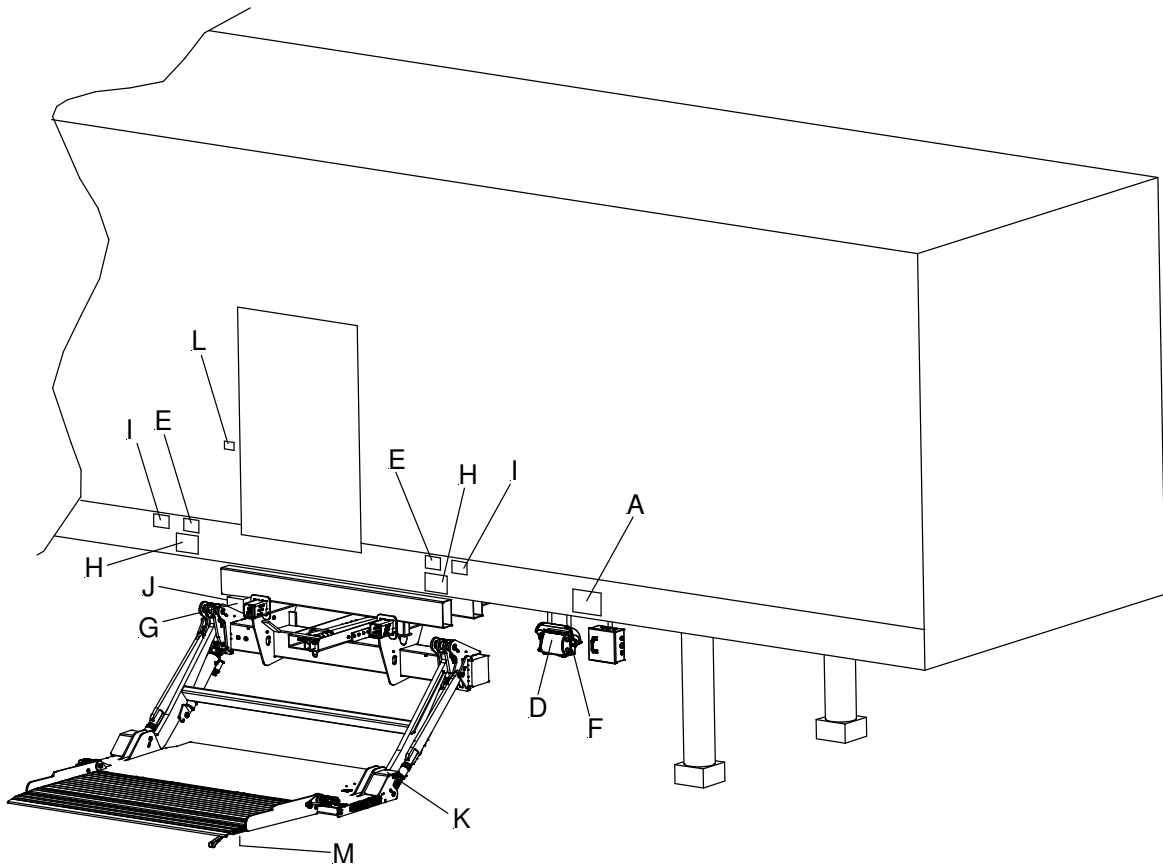

**URGENT WARNING**

BEFORE OPERATING LIFT, BE SURE YOU UNDERSTAND:

- Improper operation of this lift gate can result in serious personal injury. Do not operate unless you have been properly instructed, have read, and are familiar with, the operating instructions. If you do not have a copy of the instructions please obtain them from your employer, distributor or dealer, as appropriate, before you attempt to operate the lift gate.
- Always inspect this lift gate for maintenance or damage before using it. If there are signs of improper maintenance, damage to vital part, or a slippery platform surface, do not use the lift gate. Do not attempt your own repair, unless you are specifically trained.
- Do not overload. See the **Wtg. Literature and/or Rating Label** on the unit for the rated load. Remember that this limit applies to both raising and lowering operations.
- Each foot should be placed in a stable position as near as possible to the center of the platform.
- Never allow yourself, a helper, or a bystander to stand in a position where an unstable load might fall on them. Do not allow any part of your or your helper's body to be placed under, through, or around any portion of the moving lift gate, or in a position that would trap between any parts when the lift gate is operated.
- This lift gate is intended for loading and unloading of cargo only. Do not use this lift gate for anything but its intended use. The lift gate is not equipped with a back up system to prevent falling in the event of a failure.

ATG-UPRBL

Decal - A

**OPERATING INSTRUCTIONS**

LOWER PLATFORM TO PREVENT DAMAGE BEFORE SLIDING

Decal - B

**OPERATING INSTRUCTIONS**

LOWER PLATFORM TO PREVENT DAMAGE BEFORE SLIDING

Decal - C

**OPERATING INSTRUCTIONS**

ILSL 33/44

To operate this lift gate, you must understand the operating instructions and warnings.

- Make certain the platform is clear before operating the lift.
- Liftgate shutoff switch must be turned off when platform is not in use.
- Keep platform in horizontal position when loading and unloading.
- Do not overload, refer to capacity decal.

**Load Position:** Lower platform. Max. Capacity on Platform.

**Stow Position:** Raise platform. Max. Capacity on Platform.

For questions regarding operation call 888-774-8888

Decal - D

**CAUTION**

Maximum Load Capacity  
**4000 pounds.**

Center load on platform to avoid personal or property damage.

ATG-000

Decal - E

**NOTICE**

LIFT GATE SHUT-OFF TO BE TURNED OFF WHEN LIFT IS NOT IN USE

ATG-CAB

Decal - F

**NOTICE**

ELECTRICAL SYSTEM PROTECTED BY RESETTABLE CIRCUIT BREAKER

TO RESET - PUSH RESET TAB IN

ATG-BKR

Decal - G

**WARNING**

LIFTGATE HAZARDS CAN RESULT IN CRUSHING OR FALLING

KEEP HANDS AND FEET CLEAR OF PINCH POINTS

IF RIDING LIFTGATE, MAKE SURE LOAD IS STABLE AND FOOTING IS SOLID

READ AND UNDERSTAND ALL INSTRUCTIONS AND WARNINGS BEFORE USE.

ATG-001

Decal - H

**CAUTION**

ALWAYS STAND CLEAR OF PLATFORM AREA

ATG-002

Decal - I

**NOTICE**

ELECTRICAL SYSTEM IS PROTECTED BY A RESETTABLE CIRCUIT BREAKER. SEE OWNER'S MANUAL AND DECAL LOCATED AT THE BATTERY.

ATG-RESST

Decal - J

**NOTICE**

**DOWN:** Step on switch 1 and hold - wait between one and three seconds before you step on switch 2.

**UP:** Step on switch 2 and hold - wait between one and three seconds before you step on switch 1. The platform will lift up to greatest position before raising.

If both switches are not activated within three seconds start over.

ATG-003

Decal - K

**NOTICE**

UP

DOWN

ATG-UD

Decal - L

**WARNING**

USE HANDLE TO OPEN ALWAYS STAND CLEAR OF PLATFORM AREA WHEN OPERATING THIS GATE

ATG-WHG

Decal - M

## 6.5 Quick Check List

1. Operate the lift gate throughout its entire operation and check for noise and damage such as bent parts or cracked welds.
2. Inspect all welds and fasteners that attach the mount frame to the truck. All pins and bolts that connect the lift arm to the mount frame and to the platform.
3. Visually inspect the hydraulic lines for damage, scratches, bending or leakage.
4. Inspect the cylinders for leakage and that the cylinder pins are secured with lock bolts.
5. Check the oil level when the platform is down at ground level. The level should fall between the upper markings 5 and 7 on the tank. We recommend replacing oil after the first 1200 cycles, after that on a yearly basis in the fall before winter begins.
6. Check for oil leakage around the power pack and inside mount tube. Tighten or replace components if needed. If you perform work on any hydraulic components bleed the air out of the system by operating all functions several times.
7. Check all electrical connections. Clean and protect battery terminals and check for tightness.
8. Inspect all the terminals on the solenoid-operated valves at the port of the cylinder. Lubricate the terminals for better protection from oxidation if needed.
9. Grease all zerks on the lift gate and make sure they all take grease. Sometimes it helps to operate the lift gate while you do this.
10. Test all the lift gate functions.
11. Check the function of the pressure relief valve.
12. When doing daily checks and you find any kind of damage that can make the use of the liftgate dangerous, it must be repaired before using. All repairs should be made by an authorized technician. Use only original spare parts. If in doubt contact your PALFINGER Liftgates distributor or call PALFINGER Liftgates directly.



**Do not cover up any accidents or damage; it can be dangerous for you and your co-workers.**



## 7 Troubleshooting

### ATTENTION:



**Please check the following points before identifying any faults.**



Serious injuries are possible from tools short circuiting main battery connections. Do not leave tools or other equipment that may cause shorts around the battery.

- Please change oil after working on hydraulic unit (removal of valves, opening of cylinder etc.)
- There is a possibility of injury if somebody other than an authorized technician works on the liftgate.
- Injuries are possible if short circuits are caused by tools, jewelry, or other conductive objects on or near the battery connections.

### 7.1 Liftgate will not power on.

#### 1. Check the shut off switch.

Turn ON the ON/OFF switch located in the control box.

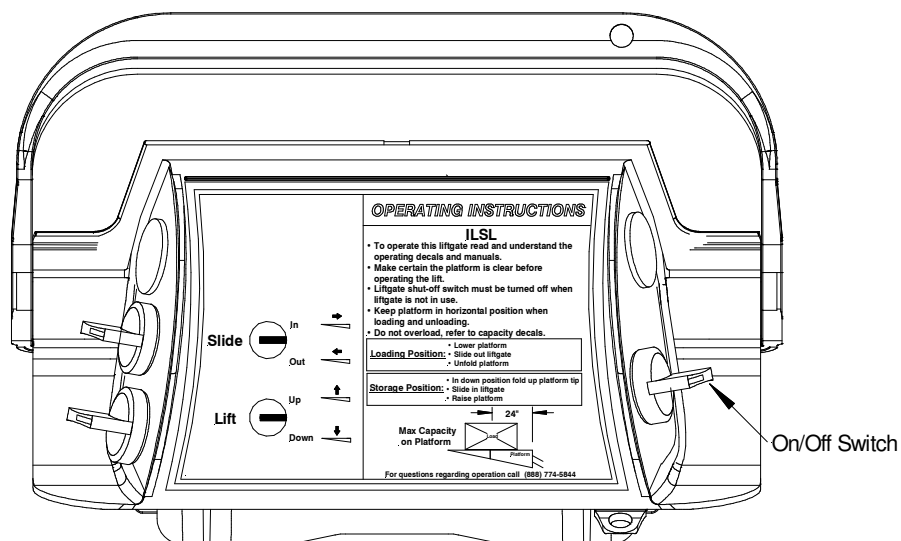

**2. Check the circuit breaker at the main batteries.**

Every truck has a circuit breaker on top of the main battery or if you have a studio unit, or a trailer, you will also find an auxiliary battery kit as shown in the illustration below.

If circuit breaker reset tab is exposed, push it back in as shown on the decal ATG-BKR next to the circuit breaker or on battery box lid.

Battery Mount

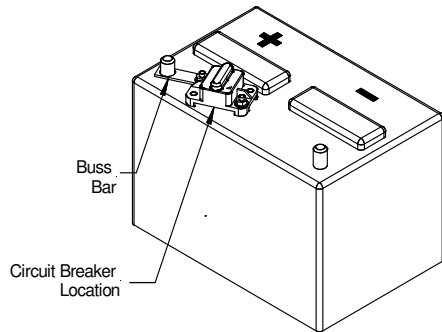

Battery Box Mount

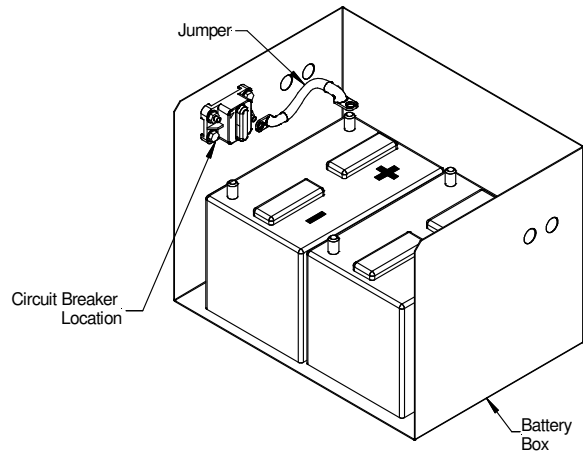

*Truck Battery*

*Auxiliary Battery*

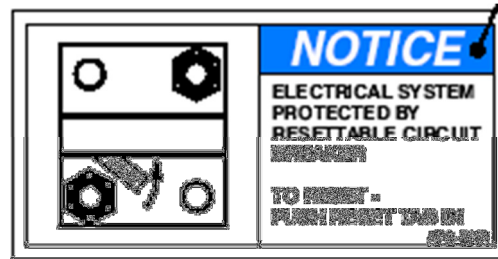
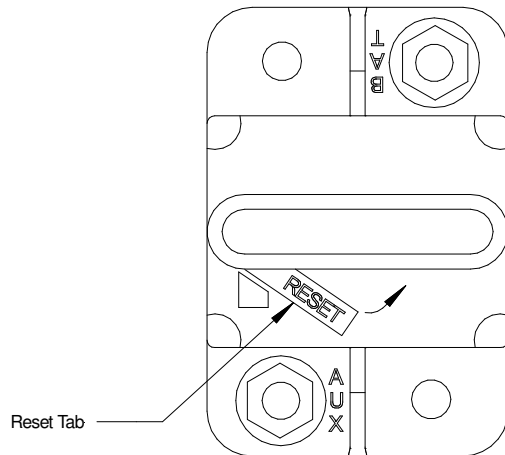

*Circuit Breaker Needs to be Reset when Reset tab is exposed*

### 3. Are the vehicle batteries charged?

Check batteries and the truck/trailer charging system. Start truck and run engine in fast idle for charging the batteries. If liftgate starts working, recharge and load test batteries.

### 4. Check the fuse(s) at the control board and battery.

The control board inside the hydraulic power unit box has two 15 Amp fuses and at the batteries there should be a 20 Amp fuse. Check all fuse holders for blown fuse(s) and replace each blown fuse with the same amperage.



**DO NOT use higher amperage fuse.**

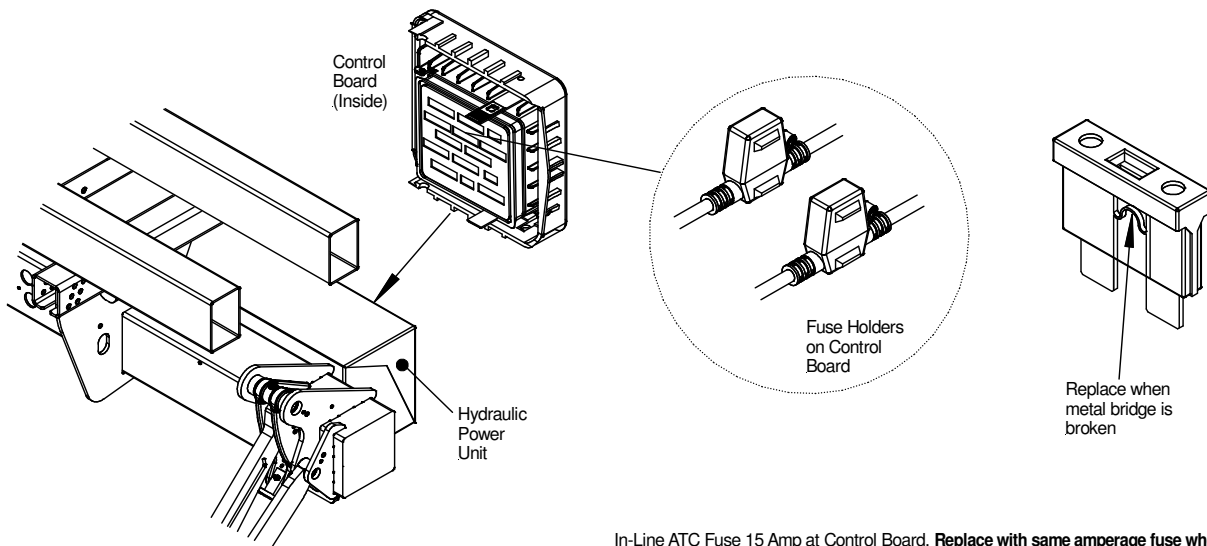

In-Line ATC Fuse 15 Amp at Control Board. **Replace with same amperage fuse when necessary.**  
In-Line ATC Fuse: 20 Amp at Battery. **Replace with same amperage fuse when necessary.**  
**NOTICE: DO NOT attempt to jump in-line fuses with other objects other than the specified fuse(s).**  
**DO NOT increase the amperage rating of fuse. Serious harm to the liftgate will result when standard practices are not followed.**

### 5. Is the connection to ground in power pack OK?

Is the ground connection from the tail lift to vehicle OK?

### 6. Check the oil level in the Hydraulic Power Unit.

The Hydraulic Power Unit is located inside the mount tube. To access the oil reservoir, remove the screw and slide out the Power Unit until there's access to the oil reservoir. Check the oil level is between the 5 and 7 level.

### 7. Are there any damages on mechanical or electrical parts (such as damaged cables)?

Perform a visual inspection of all electrical wiring and mechanical components.

## 7.2 ON/OFF switch is ON but all functions are dead

Possible malfunctions:

1. Short in hand held remote or its wire, unplug hand held control at J31. Remove J1 plug for 5 seconds. Reinstall J1, try main control board switches. If gate operates the problem is in the hand held control or its wiring.
2. Short in control box wire remove J30 plug. Remove J1 plug for 5 seconds. Reinstall J1, try hand held remote. If gate operates the problem is in the control box switches or harness.  
After disconnecting plugs – reboot board by unplugging J-1 for 5 seconds and plug it back.



If gate is still not working, take truck/trailer to an authorized repair station.

### 7.3 Electrical Wiring

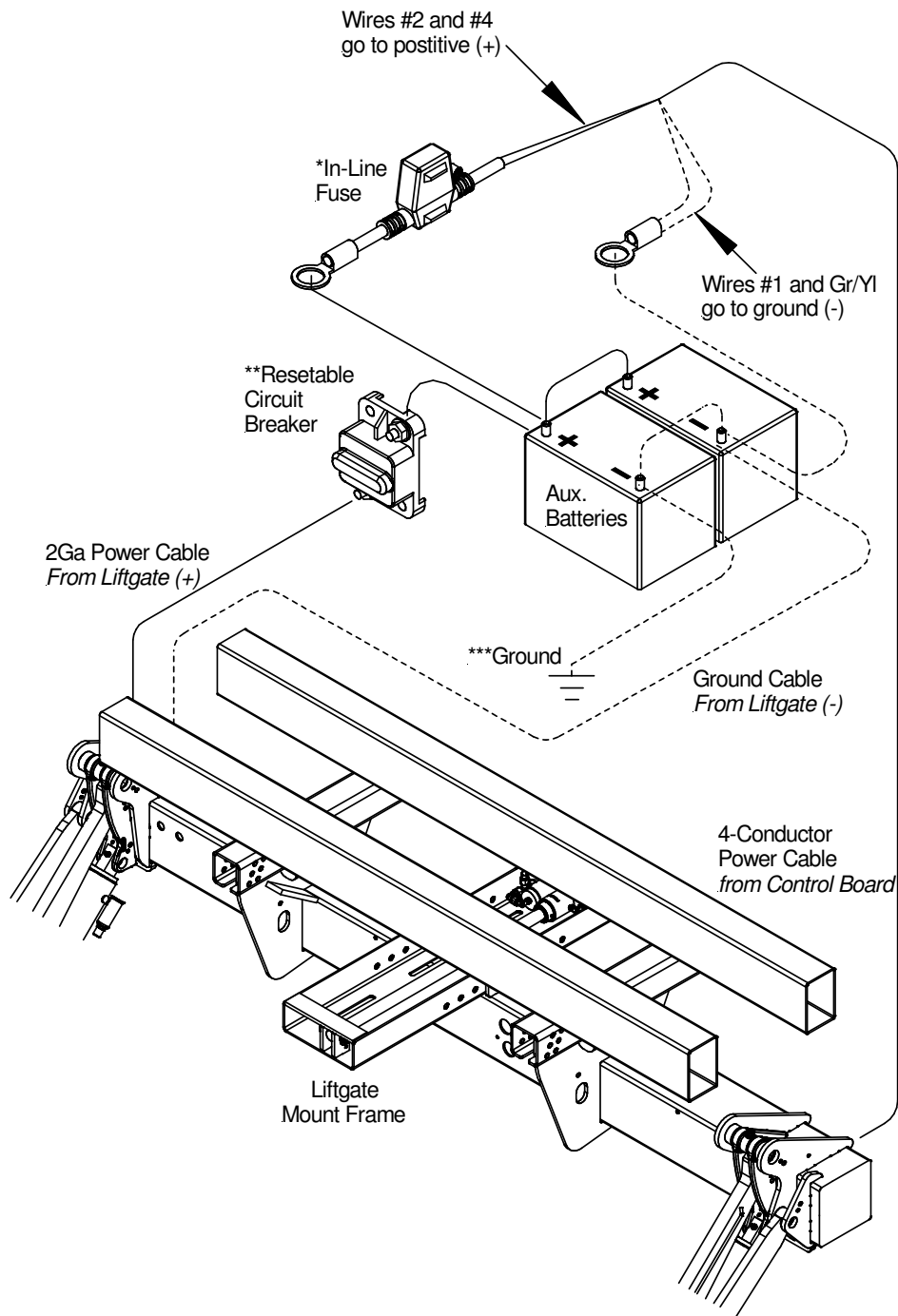

\*In-Line ATC Fuse: 20 Amp. **Replace with same amperage fuse when necessary.**

\*\*Resettable Circuit Breaker: 150 Amp Min. **Replace with same amperage breaker when necessary.**

\*\*\*Ground: For optimal grounding, ground all batteries and power units to the body side rails of the vehicle.

**NOTICE: DO NOT attempt to jump in-line fuses with other objects other than the specified fuse.**

**Do not increase the amperage rating of fuse. Serious harm to the liftgate will result when standard practices are not followed.**

#### Auxiliary Batteries Wiring

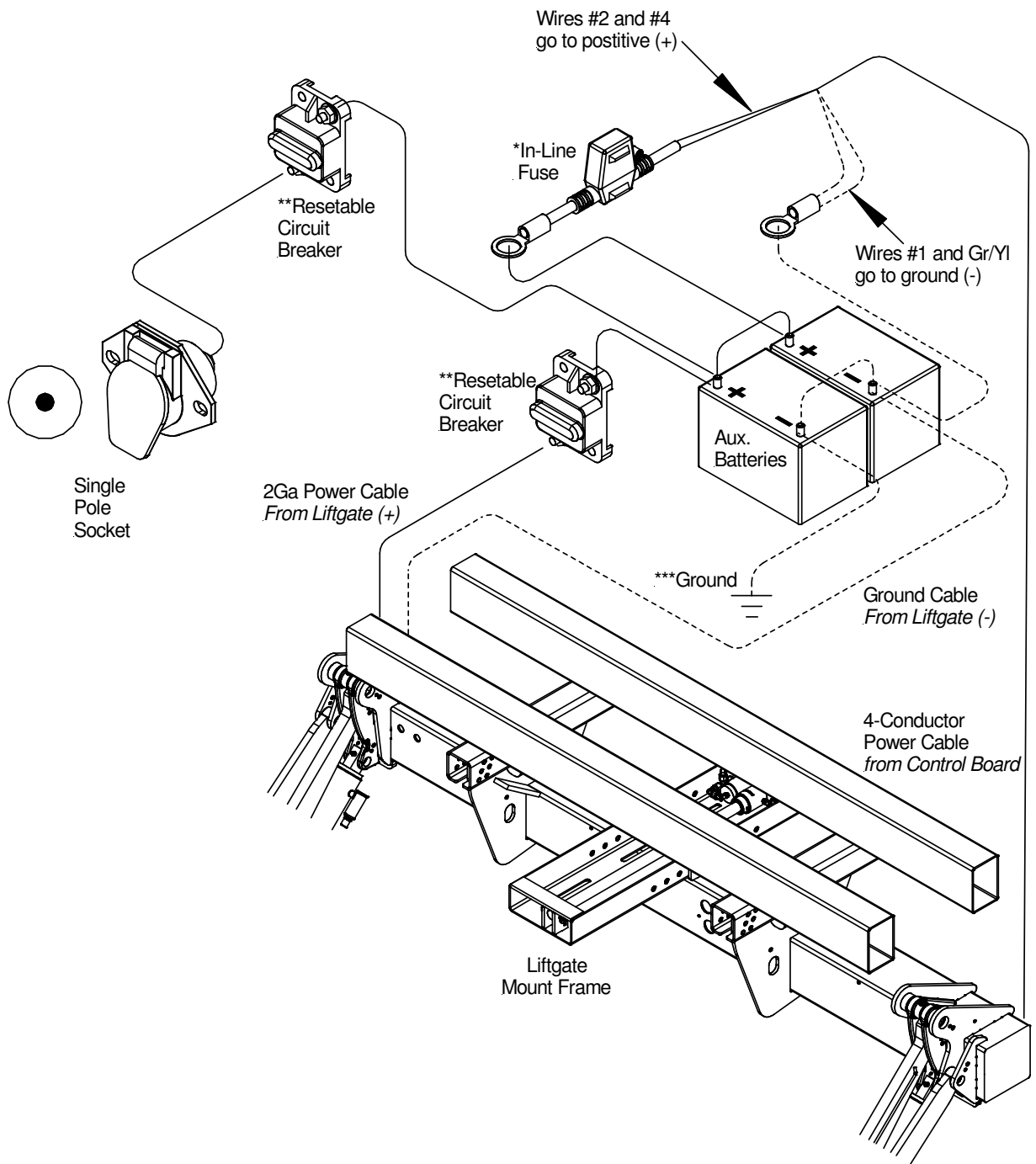

\*In-Line ATC Fuse: 20 Amp. **Replace with same amperage fuse when necessary.**  
 \*\*Resettable Circuit Breaker: 150 Amp Min. **Replace with same amperage breaker when necessary.**  
 \*\*\*Ground: For optimal grounding, ground all batteries and power units to the body side rails of the vehicle.  
**NOTICE: DO NOT attempt to jump in-line fuses with other objects other than the specified fuse. DO NOT increase the amperage rating of fuse. Serious harm to the liftgate will result when standard practices are not followed.**

Single Pole Plug Charging System

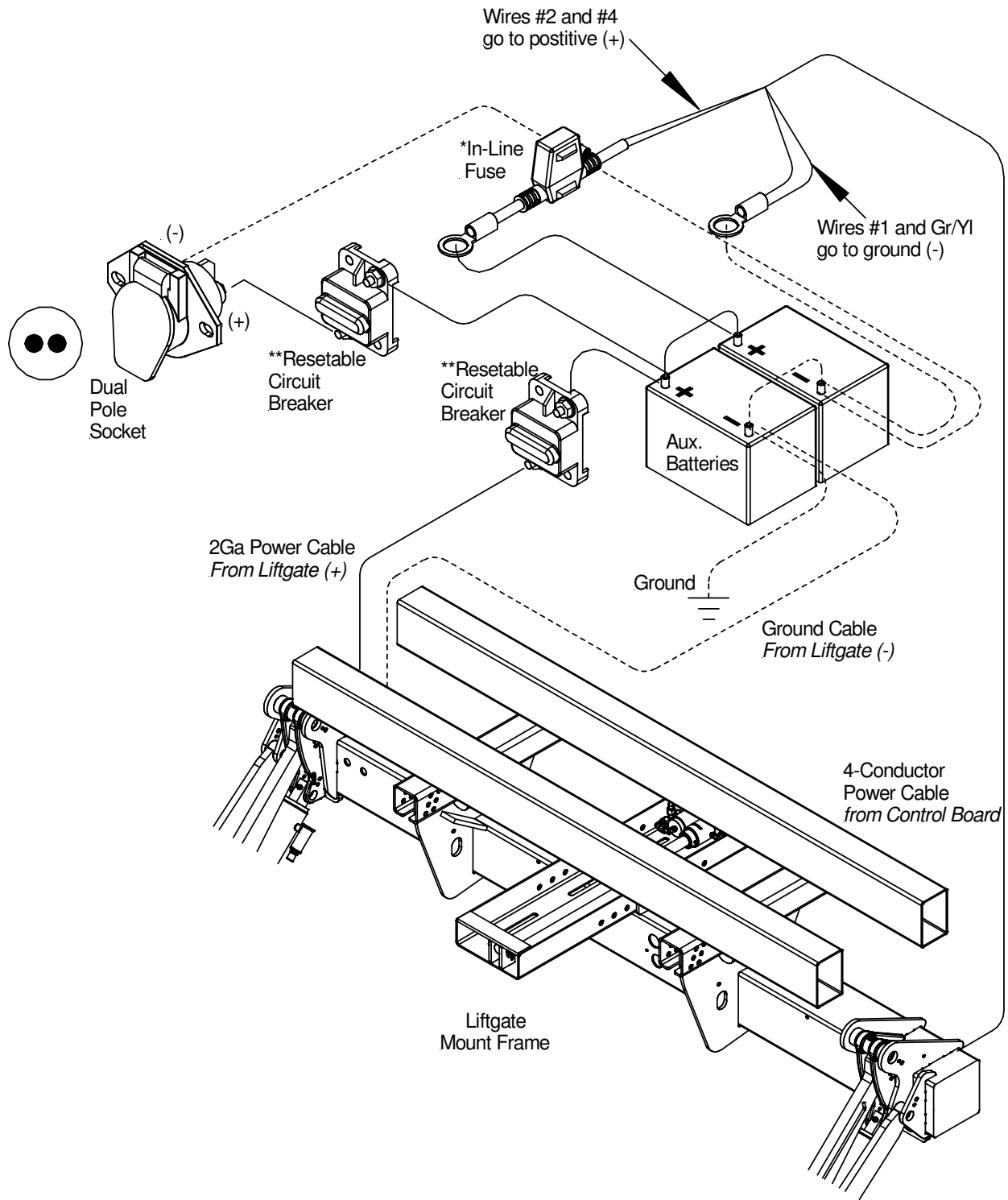

\*In-Line ATC Fuse: 20 Amp. **Replace with same amperage fuse when necessary.**  
 \*\*Resetable Circuit Breaker: 150 Amp Min. **Replace with same amperage breaker when necessary.**  
**NOTICE: DO NOT attempt to jump in-line fuses with other objects other than the specified fuse. DO NOT increase the amperage rating of fuse. Serious harm to the liftgate will result when standard practices are not followed.**

Dual Pole Plug Charging System

## 7.4 Cross Test on Single Pole Plug Charge System

Testing of full system using a battery load tester. Start with testing each individual battery on both tractor and trailer before proceeding to check the system:

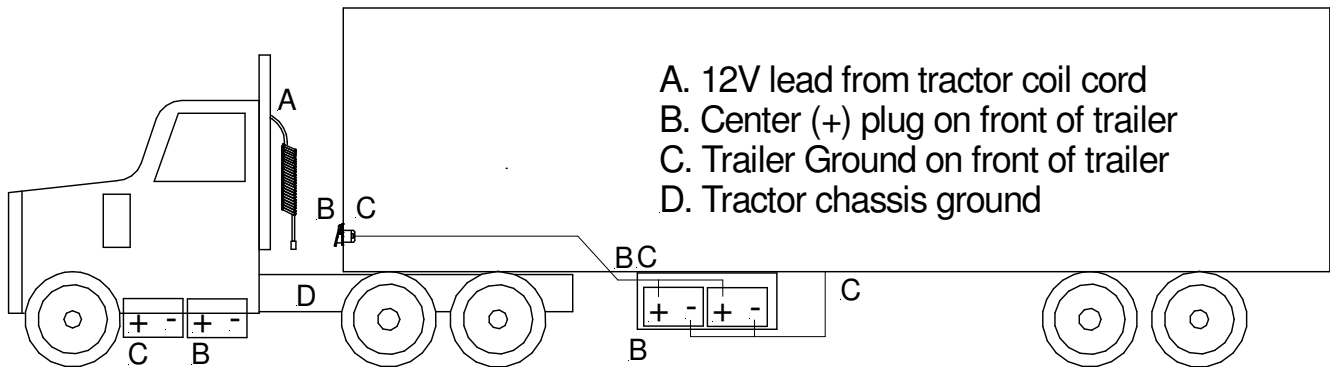

### 1. Tractor Test:

- Ground battery load tester on tractor chassis point (D)
- Connect positive load tester cable on positive pole of single pole plug at end of tractor coil cord (A)
- Run load test- This will test entire circuit on tractor including ground

### 2. Trailer Test:

- Ground battery load tester on trailer chassis point (C)
- Connect positive cable on positive pole of single pole plug receptacle on trailer (B).
- Run load test- This will test entire circuit on tractor including circuit breakers and ground between trailer batteries and trailer chassis.

### 3. Tractor and Trailer Charging system test while connected:

- Ground battery load tester on tractor chassis point (D)
- Connect positive cable on positive pole of single pole plug receptacle on trailer (B).
- Run load test- This will test entire circuit on tractor and trailer including ground between tractor, trailer, and circuit breaker on trailer.

A simple low amp voltage test at the front of the trailer or at the tractor will not show insufficient connections or ground problems.



## 7.5 Electrical Schematic

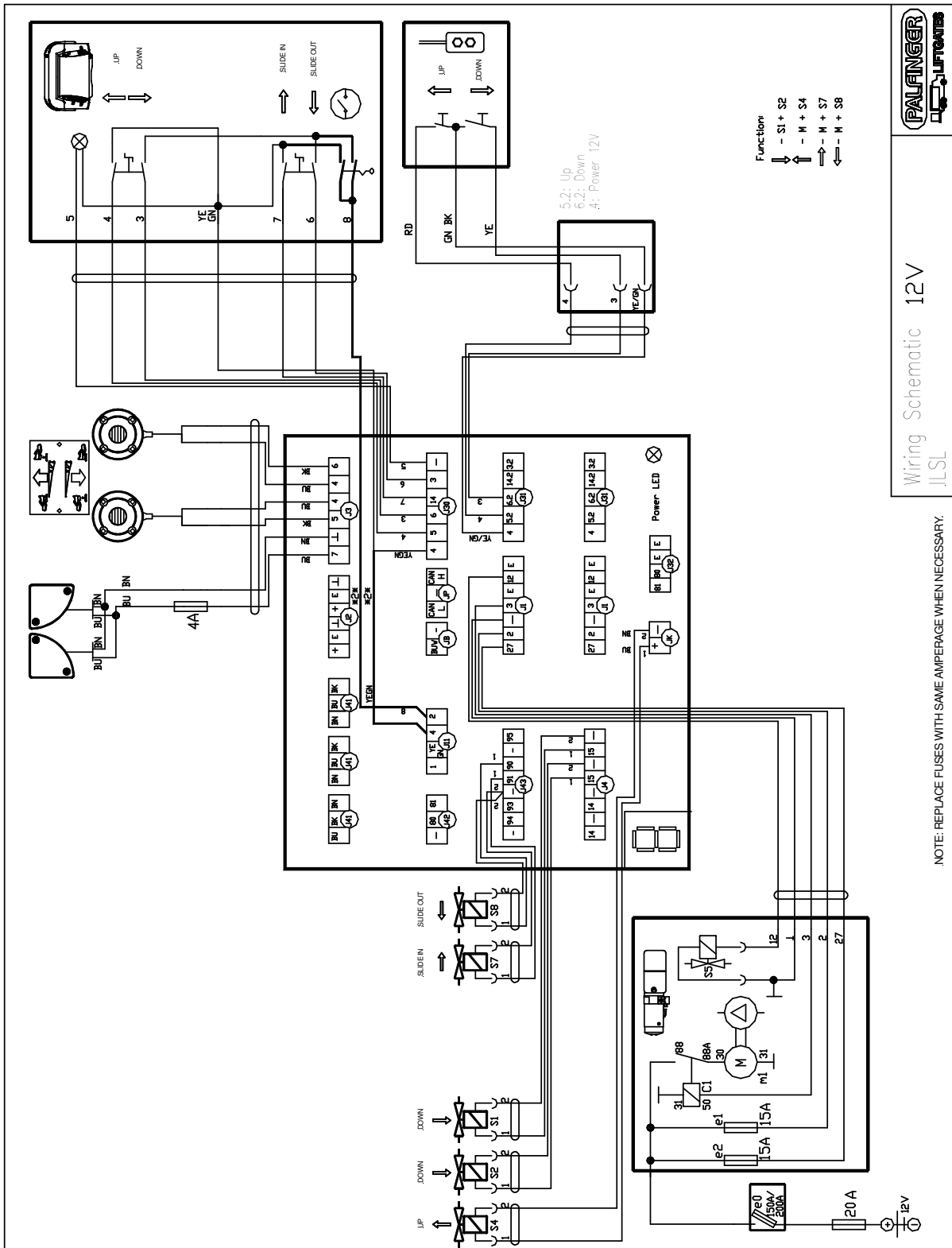

PALFINGER  
ELECTRONICS

Wiring Schematic 12V  
ILSL

Electrical Schematic

## 7.6 Control Board Connector Overview

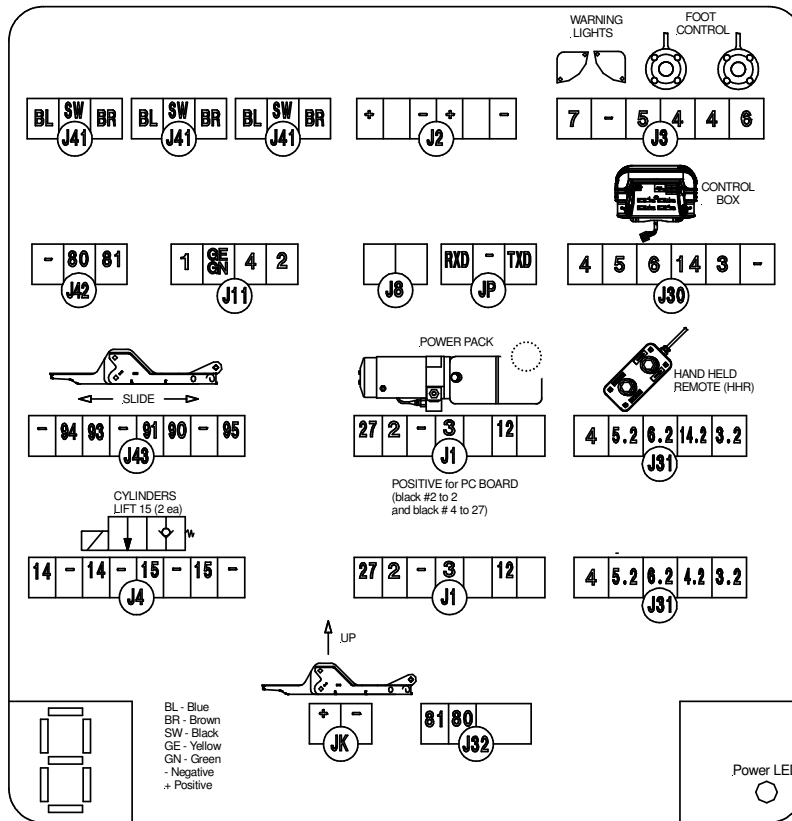

Control Board Codes:

Code	Description	Reset
0	System ok / ON/OFF switch off, (or missing bridge J11/2<->4)	
1	System ok / ON/OFF switch on, (or bridge J11/2<->4)	
2	Low Voltage	Cab switch: off/on (or disconnect bridge J11/2<->4)
3	N/A	N/A
4	N/A	N/A
5	N/A	N/A
6	Warning lights shorted	ON/OFF switch (or disconnect bridge J11/2<->4) or close tail lift
7	Short in on-off switch or aux port	Cab switch: off/on (or disconnect bridge J11/2<->4) or close tail lift
8	General short in electrical wiring	Cab switch: off/on (or disconnect bridge J11/2<->4) or voltage interruption MBB control
9	Defect at motor solenoid detected during lifting	Automatically when the valves are back to normal
A	Voltage V02 (J1 pin 2) is missing, defective fuse	Replace the fuse
b	Defect at opening, valve (S3/S4) or motor relay detected during opening	Automatically when the valves are back to normal
c	S5 valve detected during closing or motor solenoid defective	Automatically when the valves are back to normal
d	S5 valve detected or defect at lowering valve (S1/S2)	Automatically when the valves are back to normal
e	Emergency program (all sensors are bypassed). Activation by: Press Open+Lower>10 seconds	Cab switch: off/on (or disconnect bridge J11/2<->4)
p	Diagnosis mode activated	Removing service connector

### Connector Overview

## 7.7 Hydraulic Schematics

### 7.7.1 Hydraulic Schematic

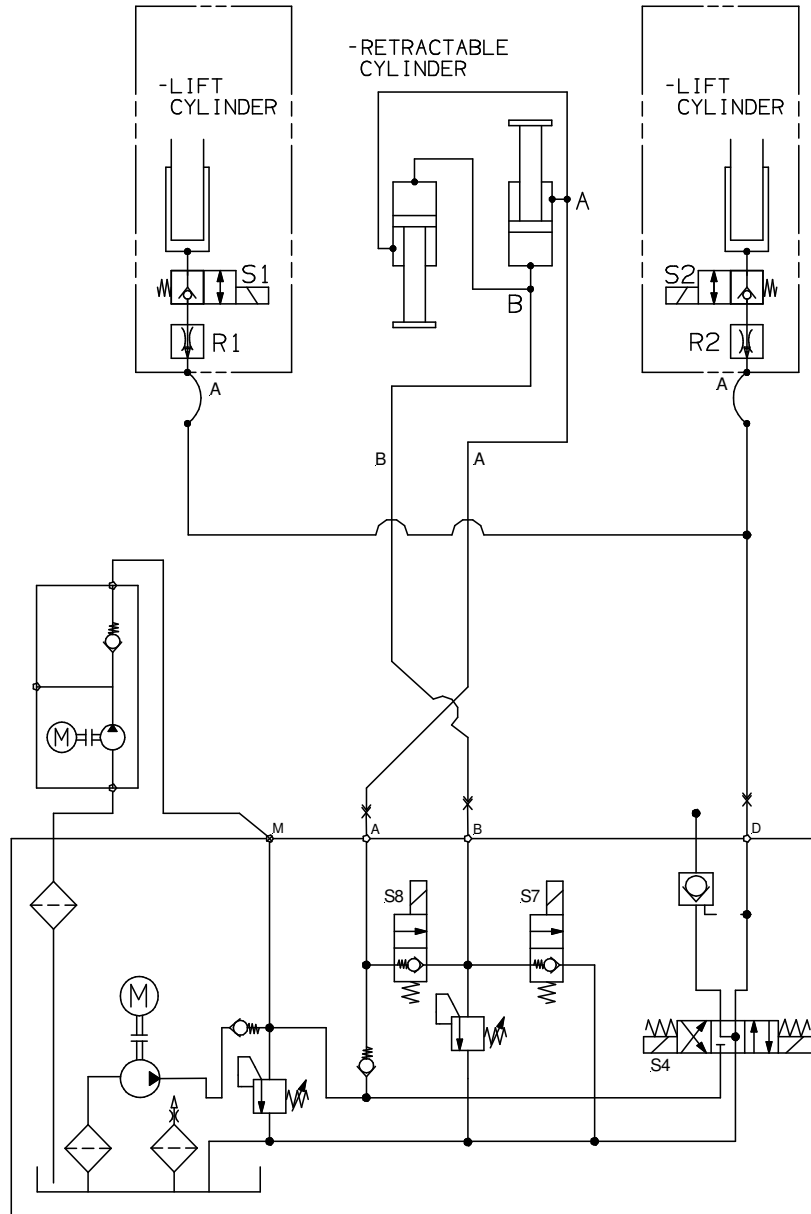

Functions:

Lift:	S4 + Motor
Lower:	S1 + S2
Slide Out:	S8 + Motor
Slide In:	S7 + Motor

### Functional Description of Hydraulics Schematic

### **7.7.2 Slide Out Function**

- As soon as the Motor starts to run, valve S8 is energized.
- Oil pressure exits pump and motor under pressure to A + B ports on push pull cylinder.
- The surface at the end of the piston rod on input "B" is larger than on the shaft at input "A".
- This creates a stronger force at the piston rod ("B") than at the shaft ("A").
- This factor forces the cylinder to extend.
- The lift gate will slide out to the end of the rails.

### **7.7.3 Lower Down**

- The solenoid release valves S1 and S2 at the cylinders get energized.
- The gate is designed to lower down by gravity. It will push the hydraulic oil out of the lift cylinder into the reservoir. The oil passes the solenoid release valves S1 and S2.

### **7.7.4 Lift Up Function**

- Motor starts running oil pressure exits pump and motor to the release valves S1 and S2 are forces the fluid to push the lift cylinders to extend. The platform raises up.

### **7.7.5 Slide In Function**

- Motor starts running and S7 valve is energized.
- The Oil pressure exits pump and motor under pressure to input "A" at the cylinder.
- The energized valve S7 is allowing the oil at the bottom of the piston rod to get back through the S5 into the reservoir.
- The pressure on the end of the shaft will force the piston rod to retract. The liftgate will slide in under the body.

## 7.8 Hydraulic Schematic (Discontinued)

### ILSL Pump/Motor Hydraulic Schematic (Discontinued)

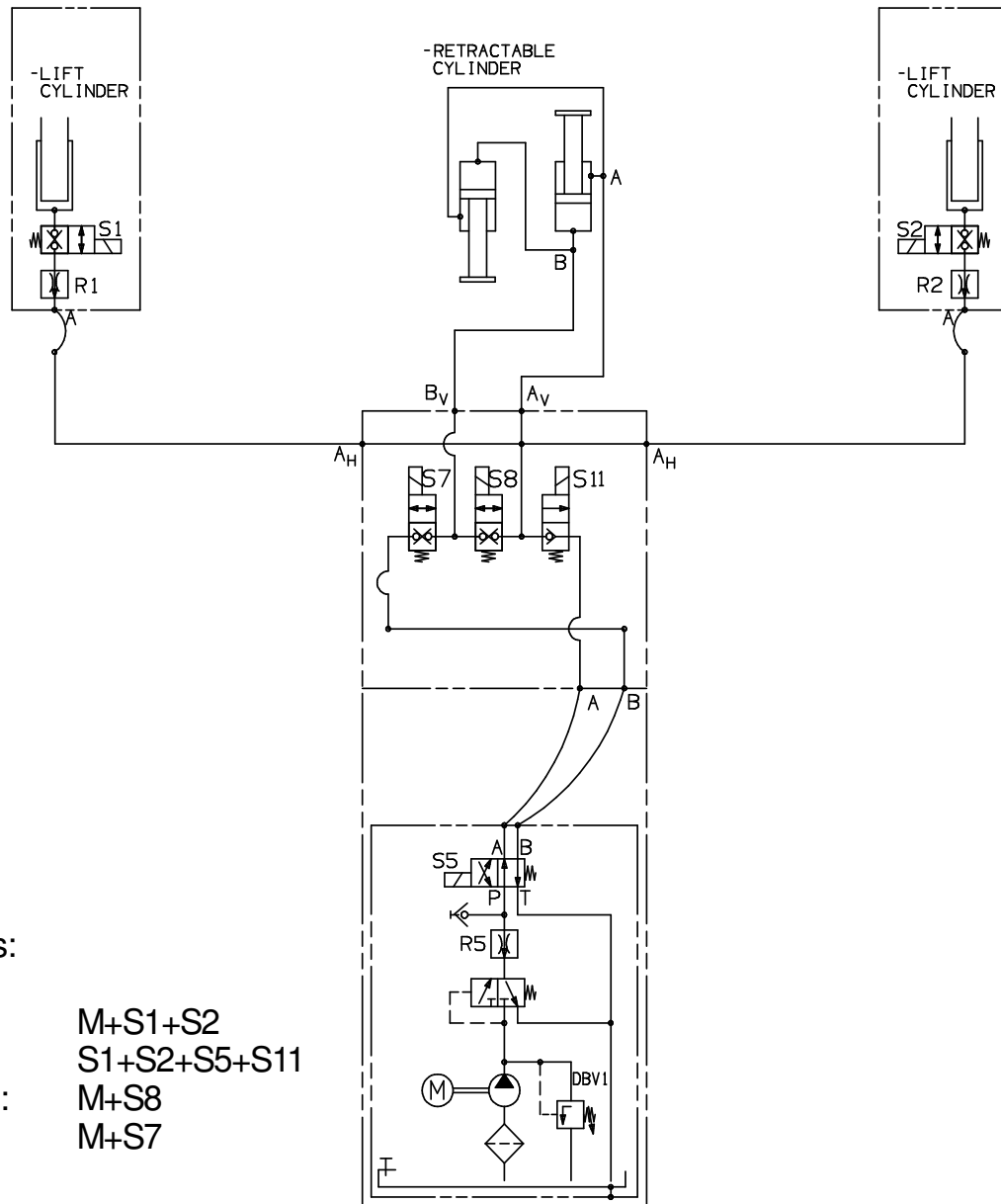

**Functions:**

- Lift: M+S1+S2
- Lower: S1+S2+S5+S11
- Slide Out: M+S8
- Slide In: M+S7

S1, S2 on lift cylinder and S7, S8 on push pull valve block are double acting release valves: They have to be activated for fluid to go through them in either direction

To slide out S8 is activated to allow fluid to both sides of retractable cylinders

To slide in S7 is activated to allow fluid to piston rod side of retractable cylinders

## **Functional Description of Hydraulics Schematic (Discontinued)**

### **7.8.1 Slide Out Function**

- As soon as the Motor starts to run, valve S8 is energized.
- Oil pressure on input “A” sets exits “Av” and Bv” at the valve block under pressure.
- The surface at the end of the piston rod on input “B” is larger than on the shaft at input “A”.
- This creates a stronger force at the piston rod (“B”) than at the shaft (“A”).
- This factor forces the cylinder to extend.
- The lift gate will slide out to the end of the rails.

### **7.8.2 Lower Down**

- The shift valve S5 at the pump and the solenoid release valves S1 and S2 at the cylinders will get energized. In addition the leaking down stop valve S11 in the back of the mount frame is also energized.
- The gate is designed to lower down by gravity. It will push the hydraulic oil out of the lift cylinder into the reservoir. The oil passes the solenoid release valves S1 and S2. It also has to pass the energized S11 valve in the back of the mount frame and the shift valve S5 at the pump.

### **7.8.3 Lift Up Function**

- Motor starts running and double locking release valves S1 and S2 are energized.
- The pressure is on input “A” at the valve block. The oil passes the S11 valve and sets pressure on exit “AH”.
- The energized double locking release valves S1 and S2 forces the fluid to push the lift cylinders to extend. The platform raises up.

### **7.8.4 Slide In Function**

- Motor starts running and S7 valve is energized.
- Oil pressure on input “A” sets pressure on exits “Av” at the valve block.
- The Oil pressure on exit “Av” at the valve block sets pressure on input “A” at the cylinder.
- The energized valve S7 is allowing the oil at the bottom of the piston rod to get back through the S5 into the reservoir.
- The pressure on the end of the shaft will force the piston rod to retract. The liftgate will slide in under the body.

### 7.8.5 Push-Pull Valving (Discontinued)

- S-8 energizes open and S7 closes to slide out
- S-7 energizes open and S8 closes to slide in.

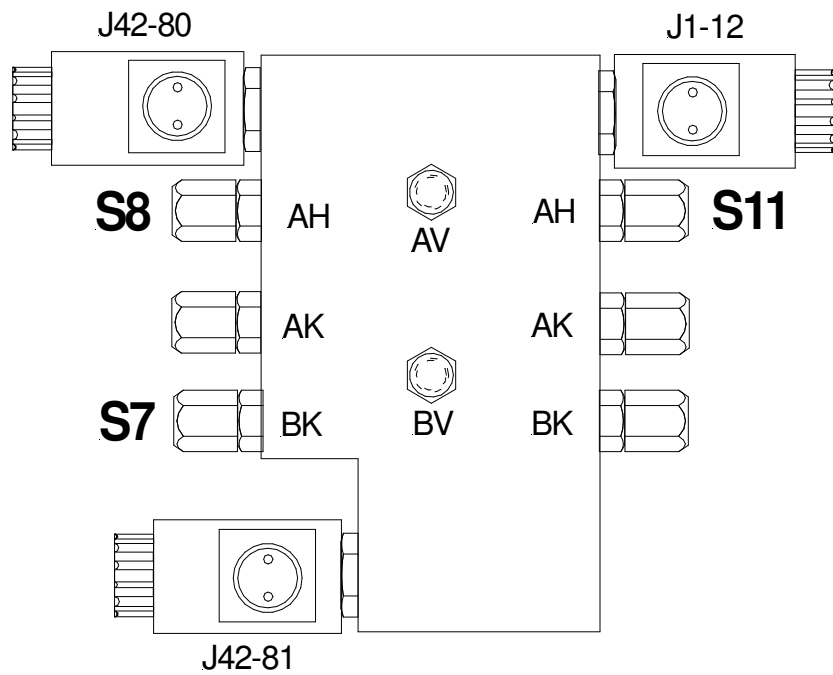

*Valve Block Setup at Main Frame*

## 8 Needed Information for Ordering Spare Parts and Repairs

### 8.1 Ordering Spare Parts

In order to assure quick delivery of spare parts, please always state the following information when making orders:

1. Liftgate model & serial number.
2. Designation and number of the spare part in accordance with the spare parts list.
3. Designation and number marked on the individual component (if available).

### 8.2 Repairs

Parts sent to PALFINGER Liftgates to repair must be accompanied by a letter (in separate cover) giving details and scope of the repairs required.

## 9 Warranty

PALFINGER Liftgates provides warranty as part of its conditions of delivery. Spare part deliveries are first of all billed. PALFINGER Liftgates then issues credit for all or part of the invoiced sum when PALFINGER Liftgates has been able to determine that the warranty claim is justified as defined by its warranty conditions. PALFINGER Liftgates does this by inspecting the defected parts which are sent back to PALFINGER Liftgates freight-prepaid as well as the written description of the problem which must have been filled out in full.

The parts that are sent back to PALFINGER Liftgates, marked with serial number and address, become PALFINGER Liftgates' property if the warranty claim is accepted.

All warranty claims must be received **within 30 days** of repair or replacement. Including the following information:

1. Liftgate model.
2. Liftgate serial number.
3. Description of problem.
4. Itemized bill of repair with breakdown of number of hours to perform warranty work and labor changes per repair.
5. Parts used for repair with PALFINGER Liftgates part number.
6. RMA#.
7. Contact at PALFINGER Liftgates, if applicable.

Model	Pump and Motor	Cylinders	Hardware	Control System	Hydraulic
ILSL	2 yrs	3 yrs	3 yrs	3 yrs	2 yr

*Warranty Coverage Schedule*

<sup>1</sup> Effective: Aug. 2010



## 10 Contact Address



15939 Piuma Ave

Cerritos, CA 90703

Phone: (562)-924-8218

Fax: (562)-924-8318

E-mail (parts order):

[liftgateparts@palfinger.com](mailto:liftgateparts@palfinger.com)

E-mail (technical support):

[technicalapplications@palfinger.com](mailto:technicalapplications@palfinger.com)



572 Whitehead Road

Trenton, NJ 08619

Phone: (609)-587-4200

Fax: (609)-587-4201

E-mail (parts order):

[liftgateparts@palfinger.com](mailto:liftgateparts@palfinger.com)

E-mail (technical support):

[technicalapplications@palfinger.com](mailto:technicalapplications@palfinger.com)