



**LIFTGATES**

---

**ILD** *plus*

**OWNER'S MANUAL**

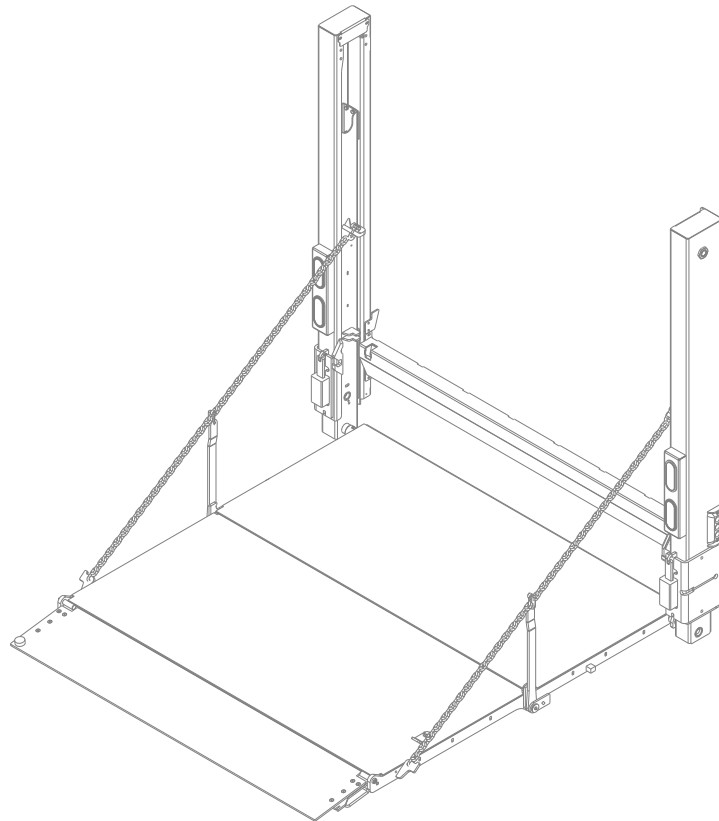

**ILD PLUS Owner's Manual**

**Document Part Number: 90-1113-150 / 13-680\_90-00\_01-50**

**ECN-M0751, Rev. 1.5, 05-13-16**

**Copyright © 2016 Palfinger Liftgates LLC.**

**All rights reserved.**

**Information in this document is subject to change without notice.**

**Visit [www.palfinger.com](http://www.palfinger.com) for up to date information and notifications.**

**If you received this product with damaged or missing parts,  
contact Palfinger Liftgates at (888)-774-5844**

**Parts Order**

**[liftgateparts@palfinger.com](mailto:liftgateparts@palfinger.com)**

**Technical Support**

**[technicalapplications@palfinger.com](mailto:technicalapplications@palfinger.com)**

**PALFINGER Liftgates, LLC.**

**15939 Piuma Ave.**

**Cerritos, CA 90703**

**Tel (888) 774-5844**

**Fax (562) 924-8318**

**PALFINGER Liftgates, LLC.**

**572 Whitehead Road.**

**Trenton, NJ 08619**

**Tel (609) 587-4200**

**Fax (609) 587-4201**

---

---

## **Introduction**

Thank you for purchasing a PALFINGER Liftgate! Your ILD series liftgate is an example of the latest engineering technology in the industry. With proper care and operation your liftgate will provide you with reliable, dependable service for years to come.

PALFINGER Liftgates is ready to provide you with fast action when you need sales, parts, or technical assistance. You can call the customer service department Monday to Friday 7 am to 5 pm Pacific Time or reach PALFINGER Liftgates 24 hours a day, 7 days a week through the internet home page ([www.palfinger.com](http://www.palfinger.com)) or voice message system. Providing quality, value and service to the customers is what our business is all about.

**Read this manual carefully** to learn how to operate and how to take care of your liftgate properly. Maintenance (other than the simple routine maintenance we ask you to perform within this manual, inspections, and repairs) must be completed by an **Authorized Service Center Only**. If you do not know who the **Authorized Service Center** in your area is, please contact Palfinger Liftgates.

## Table of Contents

<b>1</b>	<b>Safety Information .....</b>	<b>- 1 -</b>
<b>2</b>	<b>Important Information.....</b>	<b>- 2 -</b>
2.1	Important notes .....	- 3 -
<b>3</b>	<b>General Information.....</b>	<b>- 5 -</b>
3.1	Before Operation.....	- 5 -
3.2	Liftgate Function and Useage Information .....	- 5 -
3.3	Improper Useage .....	- 6 -
<b>4</b>	<b>General View of Liftgate .....</b>	<b>- 7 -</b>
4.1	General Figures .....	- 7 -
<b>5</b>	<b>Maximum Load and Placement of Load on Platform .....</b>	<b>- 9 -</b>
<b>6</b>	<b>Operation of Liftgate (Standard and Bottle Gas Units) .....</b>	<b>10</b>
6.1	Theory of Operation .....	10
6.2	Operating Instructions (Standard Units).....	10
6.3	Operating Instructions (Bottle Gas Units) .....	15
6.4	Loading and Unloading .....	- 21 -
6.5	3 Button Hand Held Control.....	- 21 -
6.6	Cart Stops.....	- 22 -
<b>7</b>	<b>Preventative Maintenance and Quick Check .....</b>	<b>- 24 -</b>
7.1	Quick Check List .....	- 24 -
7.2	Maintenance and Care .....	- 25 -
7.3	Trailer to Tractor Ground Test .....	- 26 -
7.4	Lubrication .....	- 27 -
7.5	Checking and Changing the Oil.....	- 30 -
7.6	Decal Placement and inspection .....	- 32 -
<b>8</b>	<b>Troubleshooting.....</b>	<b>- 35 -</b>
8.1	Basic Function Checks.....	- 35 -
8.1.1	LIFTGATE is completely DEAD (No Clicking or Movement at all).....	- 35 -
8.2	Battery Cable Connections.....	- 38 -
8.3	Electrical Schematic Overview .....	- 42 -
8.4	Control Board Codes.....	- 43 -
8.5	Hydraulic Schematic.....	- 44 -
8.6	Hydraulic Schematic (Pilot Check) .....	- 45 -
8.7	Hydraulic Schematic (Pilot Check and Bypass) .....	- 46 -
<b>9</b>	<b>Required Information for Ordering Spare Parts and Repairs .....</b>	<b>- 47 -</b>

9.1 Ordering Spare/Replacement Parts..... - 47 -  
9.2 Repairs..... - 47 -  
**10 Warranty ..... - 48 -**  
**11 Contact address..... - 49 -**

**Company Information:**

**Company Name:** \_\_\_\_\_

**Advisor Name:** \_\_\_\_\_

**Trailer Year Make & Model:** \_\_\_\_\_

**Liftgate Information:**

**Liftgate Serial Number:** \_\_\_\_\_

**Liftgate Model Number:** \_\_\_\_\_

**Date of Purchase:** \_\_\_\_\_

**Date of Installation:** \_\_\_\_\_

## 1 Safety Information

This manual follows the Guidelines set forth in "ANSI Z535.4-2007" for alerting you to possible hazards and their potential severity.



This is the safety alert symbol. It is used to alert you to potential personal injury hazards. Obey all safety messages that follow this symbol to avoid possible injury or death.



**! DANGER** indicates an imminently hazardous situation which, if not avoided, will result in death or serious injury.



**! WARNING** indicates a potentially hazardous situation which, if not avoided, could result in death or serious injury.



**! CAUTION** indicates a potentially hazardous situation which, if not avoided, may result in minor or moderate injury.



**CAUTION** without the safety alert symbol is used to address practices not related to personal injury. *(In this manual we use it to alert you to potentially hazardous situation which, if not avoided, may result in property damage.)*



**NOTICE** without the safety alert symbol is used to address practices not related to personal injury. *(In this manual we use it to alert you to special instructions, steps, or procedures.)*

## 2 Important Information

### Before Getting Started

## “READ FIRST”

### NOTICE

**Before starting any operations of the liftgate, please read and understand this Owner's Manual. The intention of this manual is to provide the user a guide for the operation as well as preventive maintenance. Do not attempt to modify or repair the liftgate unless performed by qualified personnel. Please contact your nearest PALFINGER Liftgates distributor or PALFINGER Liftgates in California or New Jersey for assistance if you have any questions regarding installation, operation or maintenance at 888-774-5844.**

This owner's manual applies to the following models: **ILD Plus 35, 44, 55, 66**

Maximum Capacity for liftgate models are as follows:

- ILD Plus 35 - capacity: 3500 lbs.
- ILD Plus 44 - capacity: 4400 lbs.
- ILD Plus 55 - capacity: 5500 lbs.
- ILD Plus 66 - capacity: 6600 lbs.

## 2.1 Important notes

The electric supply is taken from the battery kit in the Power Pack Box. If the vehicle battery is not sufficient, additional batteries need to be installed. The electric control power is secured via a fused circuit and an on-off switch located inside the cab.

The ILD plus series liftgate is a 100% level-ride, rail style vertical lift liftgate.

- Rail style liftgates have two rails mounted to the rear of your vehicle, either by welding or bolting. These rails support a platform which raises and lowers cargo. Lifting actions are carried out by a hydraulic cylinder which is equipped with a solenoid operated valve located at the pump and motor.
- The hydraulic power unit is easily accessible for service and exchange.
- The piston rods are treated against corrosion. The Hydraulic Power Unit is equipped with a built-in pressure relief valve, which prevents overloading when lifting.



The valves do not prevent overloading of the platform when lowering.

Additional safety features are:

- Pressure compensated flow control valve.
- Tread plate platform.
- Platform safety lock.
- Warning decals and manuals.



**⚠ WARNING**

Improper operation of this liftgate may result in severe personal injury or death. **DO NOT** operate unless you have been properly instructed, have read and are familiar with the procedures in this manual. This manual has been designed to illustrate the steps needed for the basic operation of the ILD liftgate. It also provides safety information and simple preventive maintenance tips.

**NOTICE**

This manual is not intended for use as a repair or troubleshooting guide. Repairs should be performed by a PALFINGER Liftgates Authorized Service Center.

This Manual has been designed for use in conjunction with the ILD series liftgates only which are designed for different capacities. There are four options available to determine the model and serial number of the installed liftgate:

- 1) Refer to the serial number tag on the liftgate (Located on Driver Side Column- shown below)

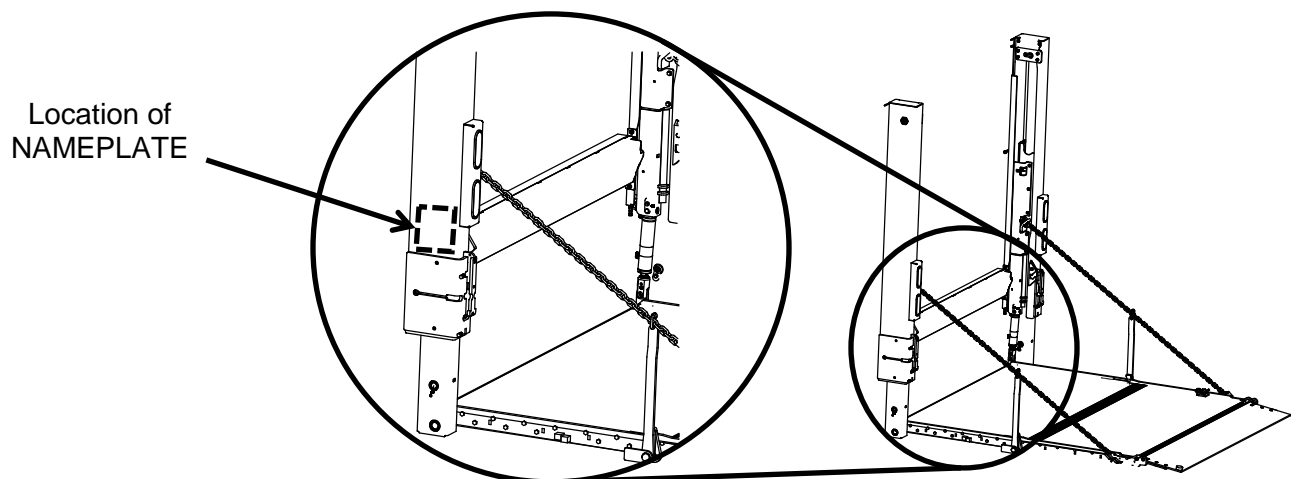

- 2) Ask your employer or lessor.
- 3) Call your PALFINGER Liftgates Authorized Service Center for assistance.
- 4) Call PALFINGER Liftgates for assistance in the USA at 888-774-5844. You can also contact PALFINGER Liftgates by fax (562) 924-8318 or on the internet- [www.palfinger.com](http://www.palfinger.com)

For technical support, contact PALFINGER Liftgates or an authorized PALFINGER service center. [www.palfinger.com](http://www.palfinger.com)

*Replacement manuals are available at no charge by contacting Customer service at 888-774-5844*

## 3 General Information

### 3.1 Before Operation

#### **REMEMBER:**

It is the fleet manager's responsibility to educate the operator on the liftgate and its intended use. The operator's attention should be drawn to the permitted load limits and an understanding of the operation to ensure the safety throughout the operation.

#### **ONE-MAN OPERATION:**

Never let an "outsider" operate the liftgate while you are handling the cargo.

A "misunderstanding" can result in serious personal injury.

In the interest of safety it is important that all operating personnel properly understand the functions of the liftgate, possible hazards, dangers, the load limits and load positioning for that specific unit.

### 3.2 Liftgate Function and Usage Information



Before the operator uses the liftgate, they should be thoroughly familiar with the liftgate functions and usage according to the following:

1. Improper operation of this lift can result in serious personal injury. Do not operate unless you have been properly instructed, have read and are familiar with the operation instructions. If you do not have a copy of the instructions please obtain them from your employer, distributor, or lessor as appropriate before you attempt to operate the lift.
2. Be certain the vehicle is properly and securely stopped before using the lift.
3. Always inspect this lift for maintenance or damage before using it. If there are signs of improper maintenance, damage to vital parts or slippery platform surface, do not use the lift. Do not attempt your own repairs unless you are specifically trained.
4. Do not overload. See the Rating Label on the unit for the rated load. Remember that this limit applies to both raising and lowering operations.
5. Each load should be placed in a stable position as near as possible to the body of the truck/trailer.
6. Never stand in, move through or allow anyone else to stand in or move through the area in which the lift operates, including that area in which a load might fall.
7. This Lift gate is intended for loading and unloading of cargo only. **DO NOT** use this Liftgate for anything but its intended use. This is not a passenger lift. Do not ride the lift with unstable loads or in such a manner that a failure would endanger you. The lift is not equipped with a back-up system to prevent falling cargo in the event of a failure.



**The maximum loads must be observed and followed!**

### 3.3 Improper Useage

Some examples of improper use of the liftgate may include, but are not limited to:

- Using the liftgate as an elevating work platform
- Using the liftgate to push, pull, or tow loads or other objects.
- Using the liftgate to carry people (Only the operator may travel on the platform)
- Using the liftgate to clear snow
- Trying to use the liftgate as a "launching pad".
- Using force of the hydraulic system to bend, shear, or break objects.
- Driving a forklift over the liftgate.
- Driving the truck or trailer with the platform open.
- Driving the truck or trailer with platform unsecured in the travel position.
- "Plowing" with the platform.

Please read through the operational and technical description of the PALFINGER Liftgate.

Thank you for choosing PALFINGER Liftgates

# 4 General View of Liftgate

## 4.1 General Figures

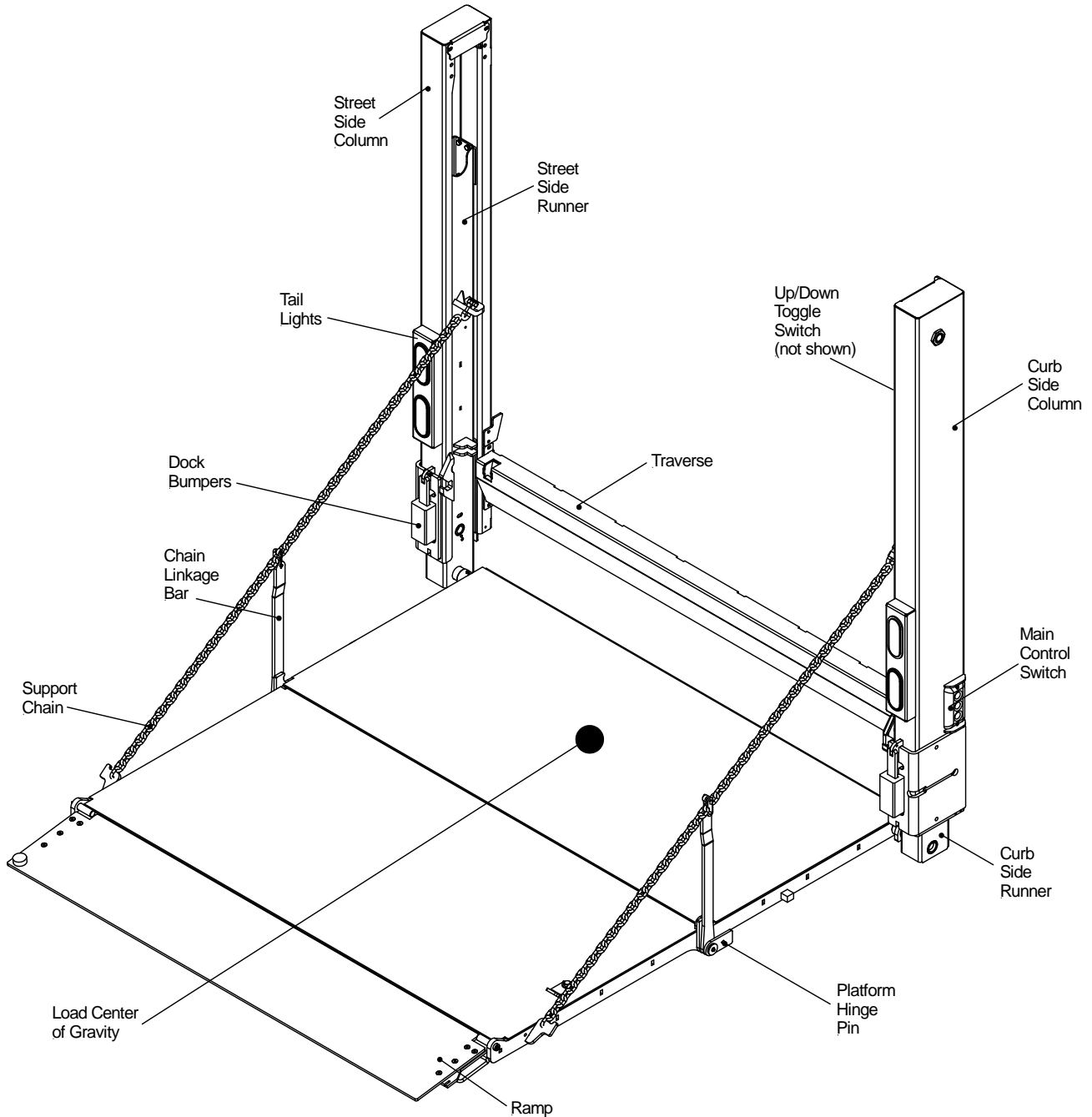

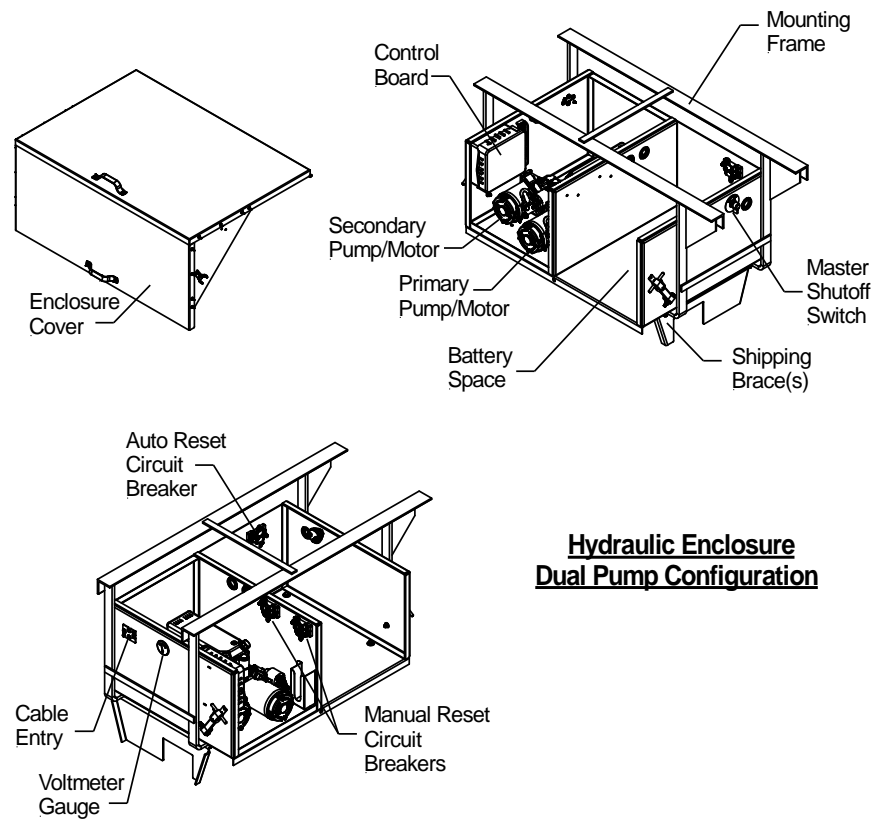
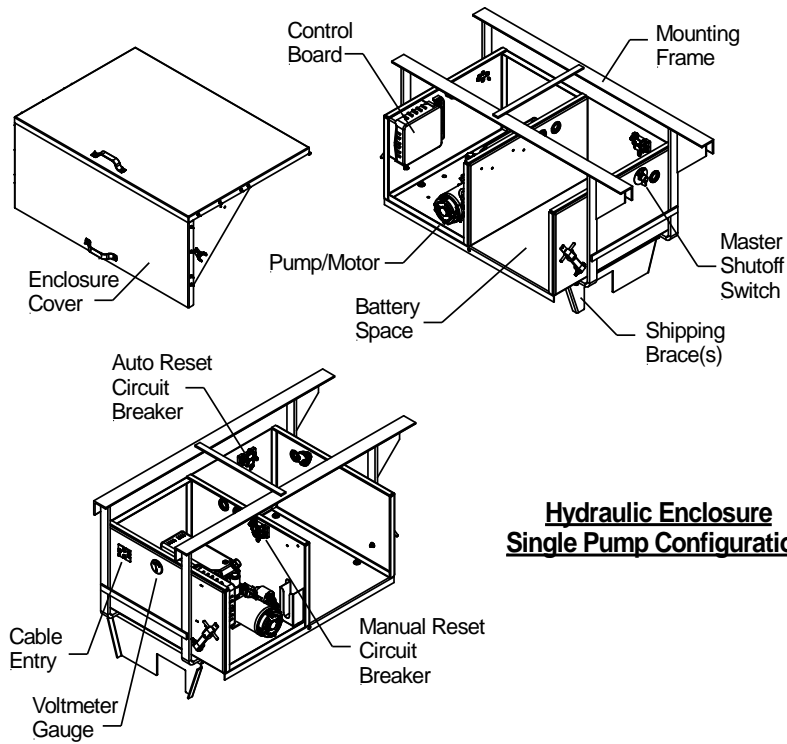

## 5 Maximum Load and Placement of Load on Platform

Every PALFINGER Liftgate is rated up to a maximum load. The point of maximum load is rated at a defined distance. The center point of maximum load is 24" from start of truck or trailer body.

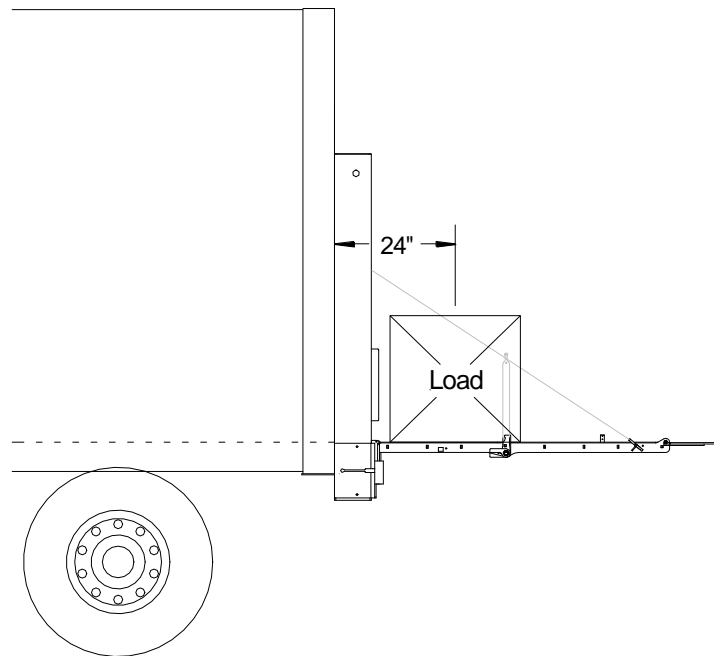

By increasing this distance the maximum load of the lift gate is decreasing. Make sure not to overload the liftgate. Place the cargo in the middle of the platform. Operating a gate with a misplaced load may cause serious damages or even injuries to the operator.

### Load Capacity vs Distance "A"

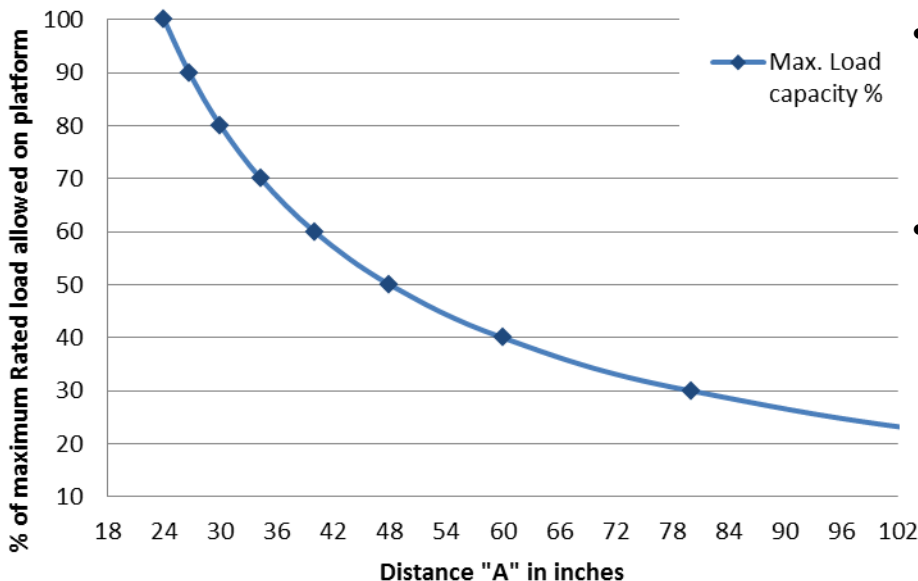

- Note that Maximum capacity is rated at 24" from the truck. As the load is placed further away from the truck, the overall capacity of the liftgate decreases.
- Never apply a load that exceeds your liftgate's maximum load rating.

## 6 Operation of Liftgate (Standard and Bottle Gas Units)

### 6.1 Theory of Operation

The rail-type liftgate is designed to transport cargo vertically from the vehicle bed to the ground and vice versa. A hydraulic power unit provides pressure to two vertical cylinders that raise and lower the platform. Activation of a control switch supplies current from a 12-volt battery source to the hydraulic power unit. The hydraulic power unit in turn supplies hydraulic fluid to the hydraulic cylinders, causing them to retract and extend.

The platform is lowered by gravity, however it also can be lowered by hydraulic power. Activation of the control buttons opens the hydraulic valves and directs hydraulic fluid to extend the cylinder. The downward force on the platform lowers it.

The platform is opened and closed hydraulically by the extension and retraction of the open/close cylinder.

### 6.2 Operating Instructions (Standard Units)

Steps:

1. Turn on power: To activate power to the liftgate, turn the master disconnect switch located on the outside of the battery box to the "ON" position

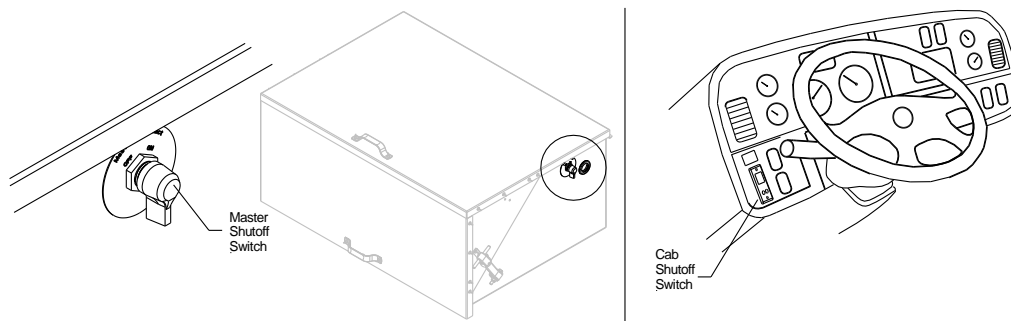

2. Open Liftgate Platform: Be certain the operating area around platform is clear before opening platform. Push and hold the "UP" button to raise the platform up so that it is completely out of the travel locks.

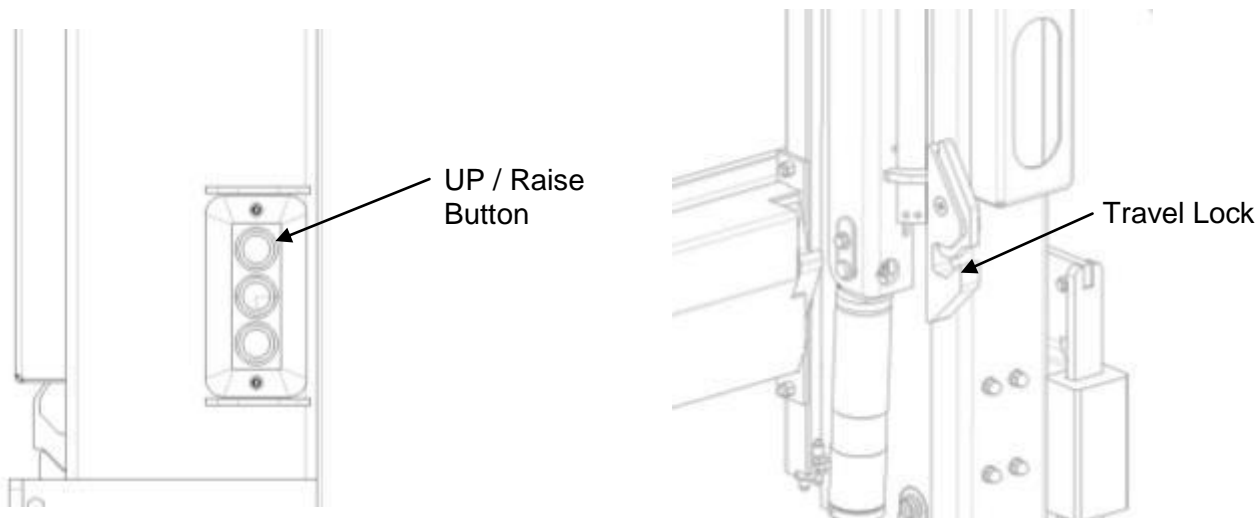

Open the Liftgate Platform (continued): Be certain operating area around platform is clear before opening platform.

Pushing the "DOWN" button, and "OPEN" button together to power the platform open.

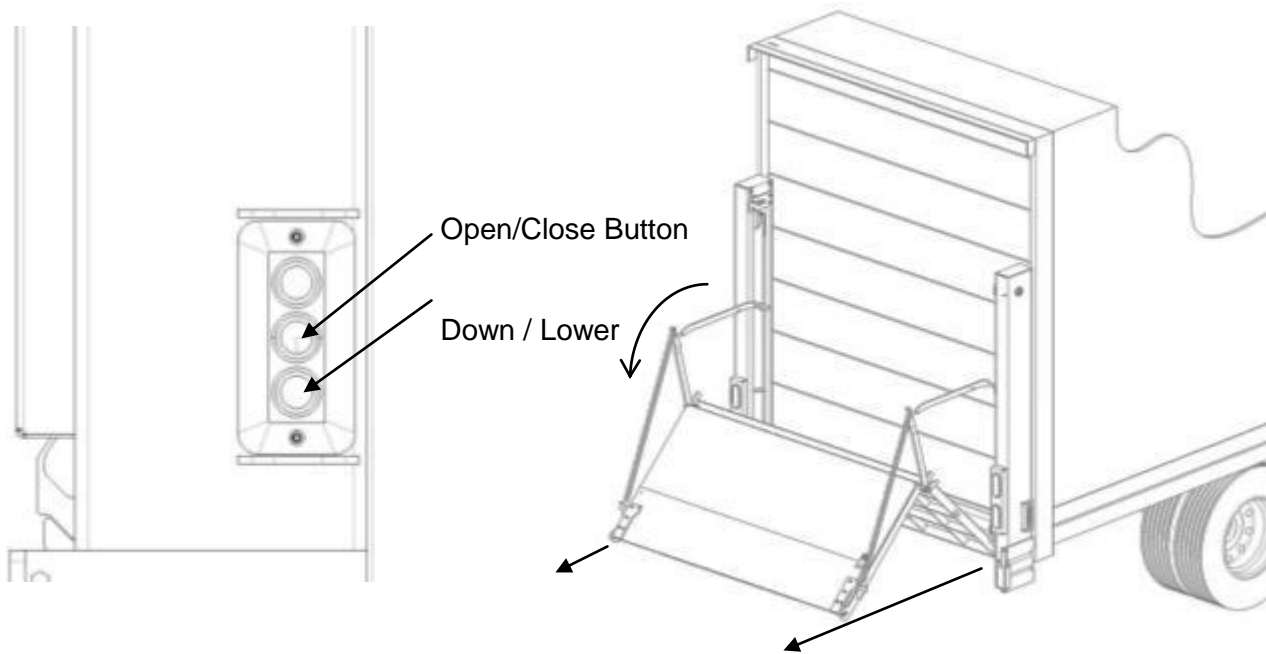

3. Lower the platform to the ground: Pushing the "DOWN" button, lower the platform to the ground.  
 Note: for power down operation, push the down button twice (within 3 seconds).

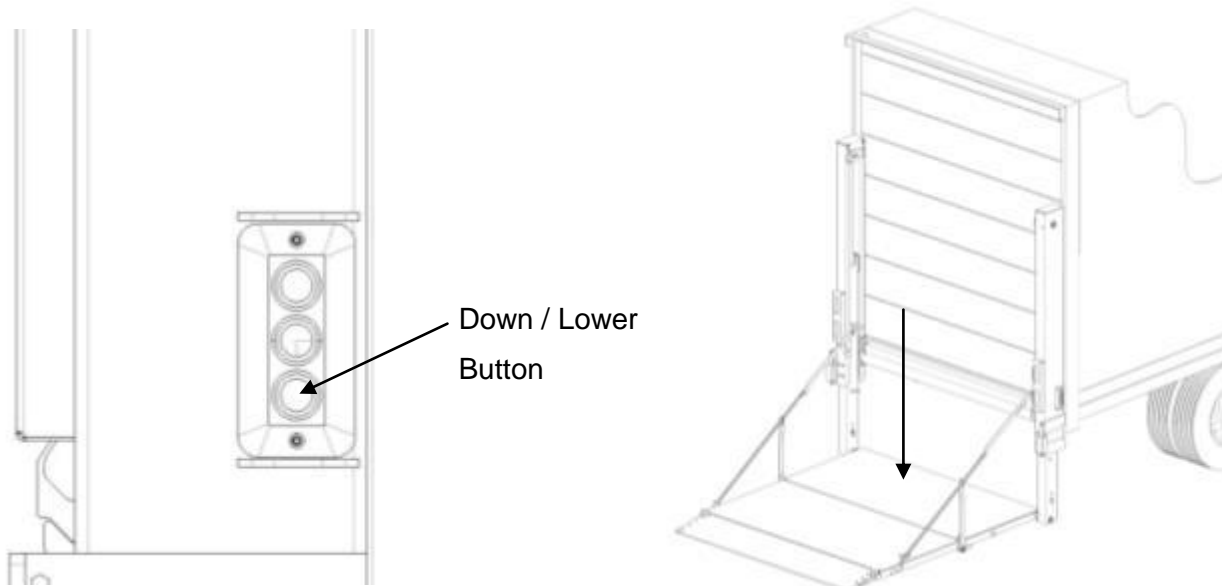



4. Raise the platform to bed level: Pushing the “UP” button, raise the platform to bed level.
5. Bleeding the system: With the platform at bed level, push the “UP” button for thirty (30) seconds. This will bypass hydraulic fluid through hydraulic poppet valves located in each of the lift cylinder pistons returning hydraulic fluid back to the reservoir via the return lines.

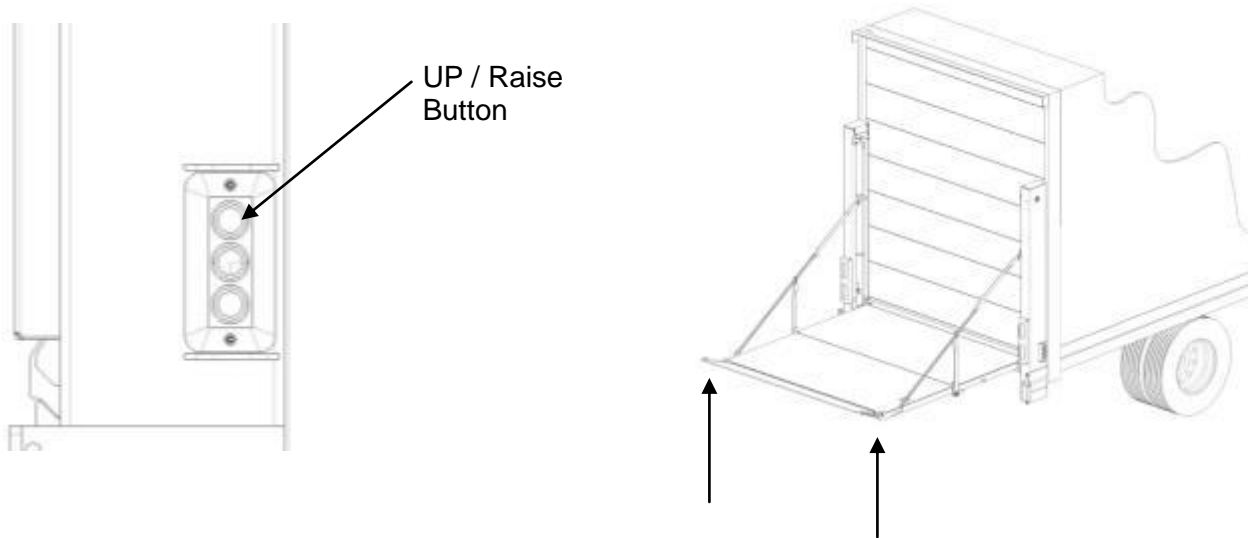

6. Closing and Storing of the Platform for transit: With the platform open at bed level use the “UP” button and “CLOSE” button together, power the platform closed.

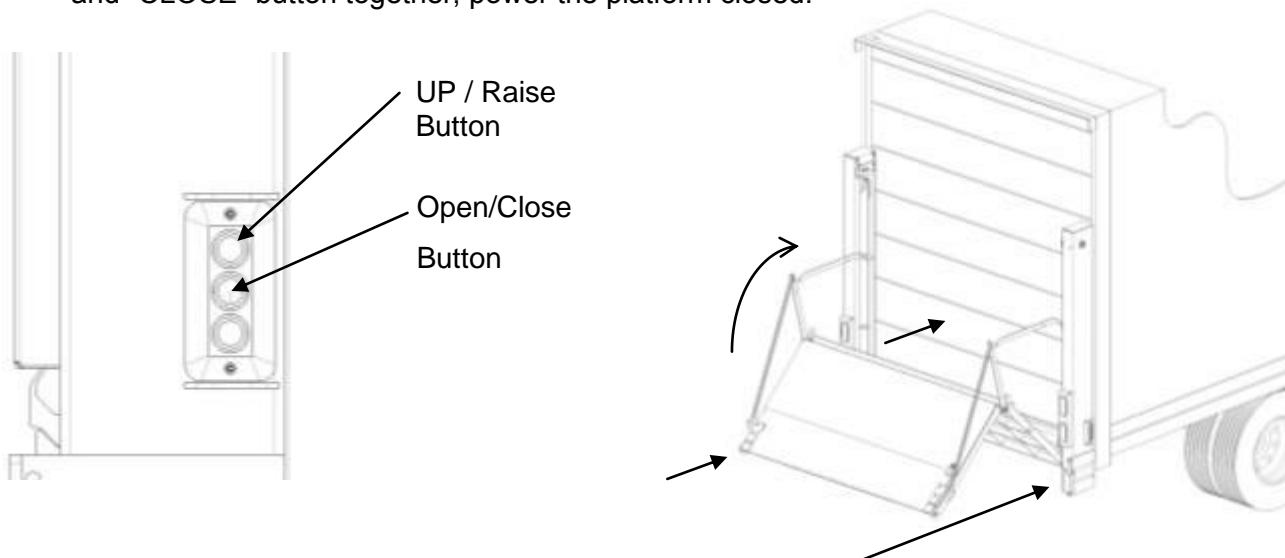

7. Lower the Platform: Using the “DOWN” button, push down twice (within 3 seconds) and power down platform past the Travel Locks. (See Illustration)

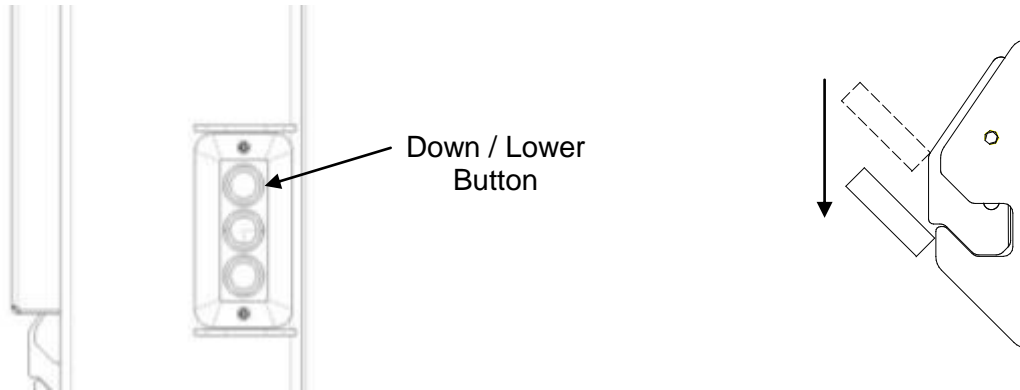

8. Raise the Platform: Using the “UP” button, raise platform up until travel ears clear the travel lock slot. (See Illustration)

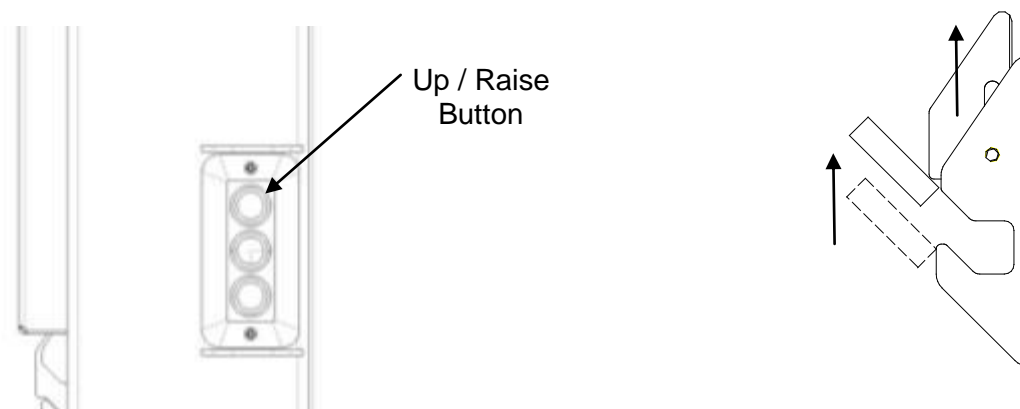

9. Lock the Platform: Once the travel ear clears the slot, use the **down button twice** (within 3 seconds) to **power down** travel ear into travel lock slot.

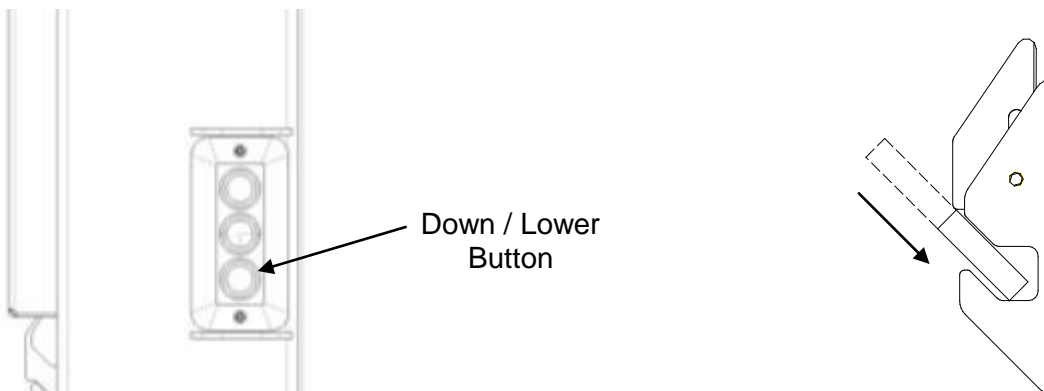

**Lowering Platform for Dock Loading (Standard Units)**

**Steps:**

1. Using the "UP" button to power platform up so that it is completely out of the travel locks.

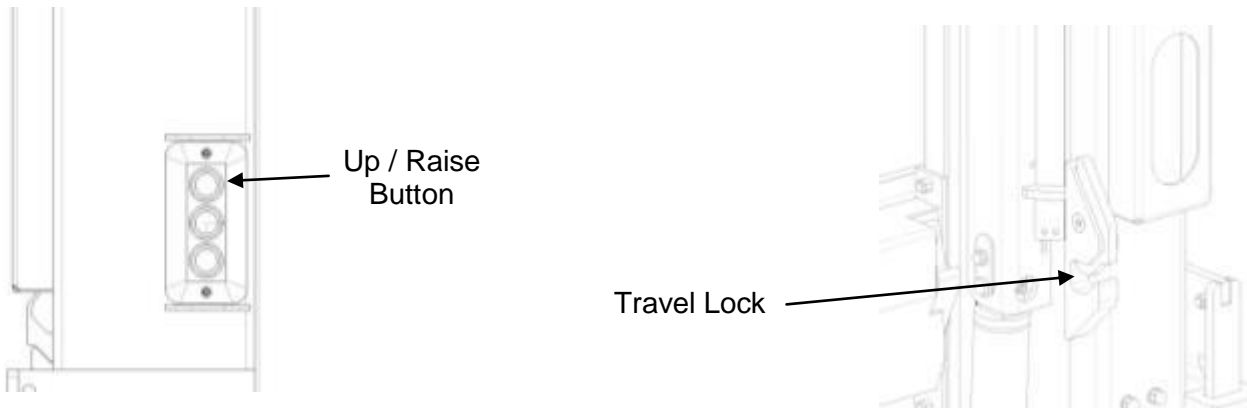

2. To lower platform down push **Down Button twice** (within 3 seconds) until the platform passes the travel latch and is level with the vehicle floor and rests on the Dock Stops.

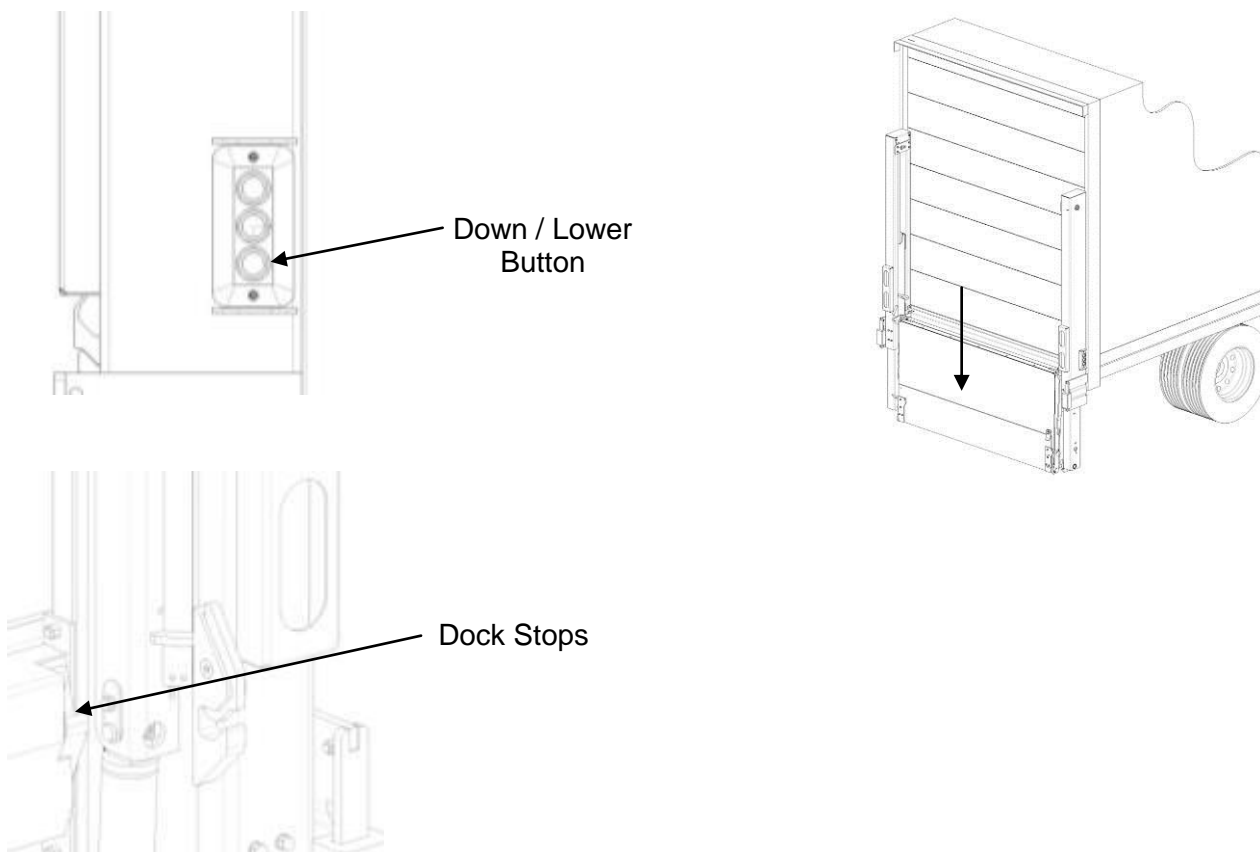

### 6.3 Operating Instructions (Bottle Gas Units)

Steps:

1. Turn on power: To activate power to the liftgate, turn the master disconnect switch located on the outside of the battery box to the "ON" position.

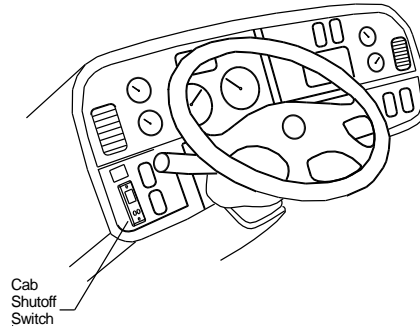
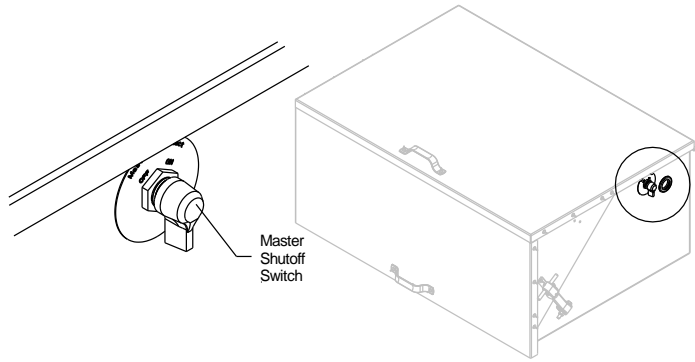

2. Open Liftgate Platform: Be certain the operating area around platform is clear before opening platform. Pushing the "UP" button, raise the platform up so that it is completely out of the travel locks.

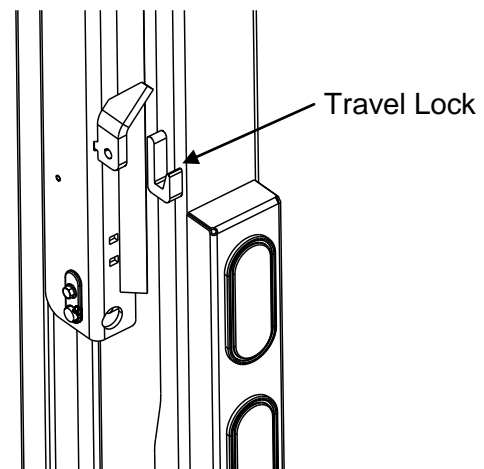
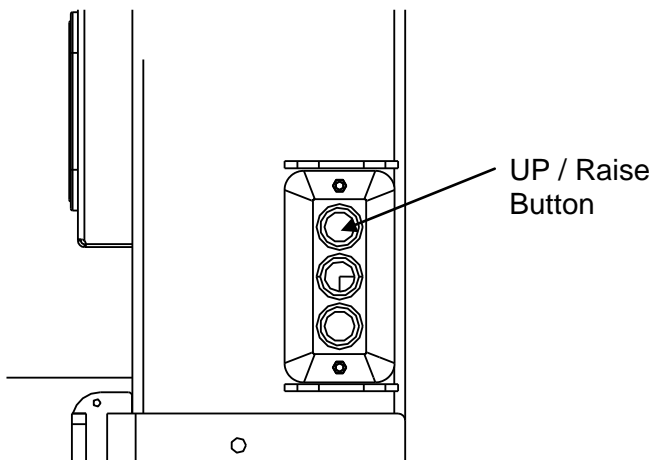

Open Liftgate Platform (continued): Be certain operating area around platform is clear before opening platform. Push the "DOWN" button, and "OPEN" button together to power the platform open.

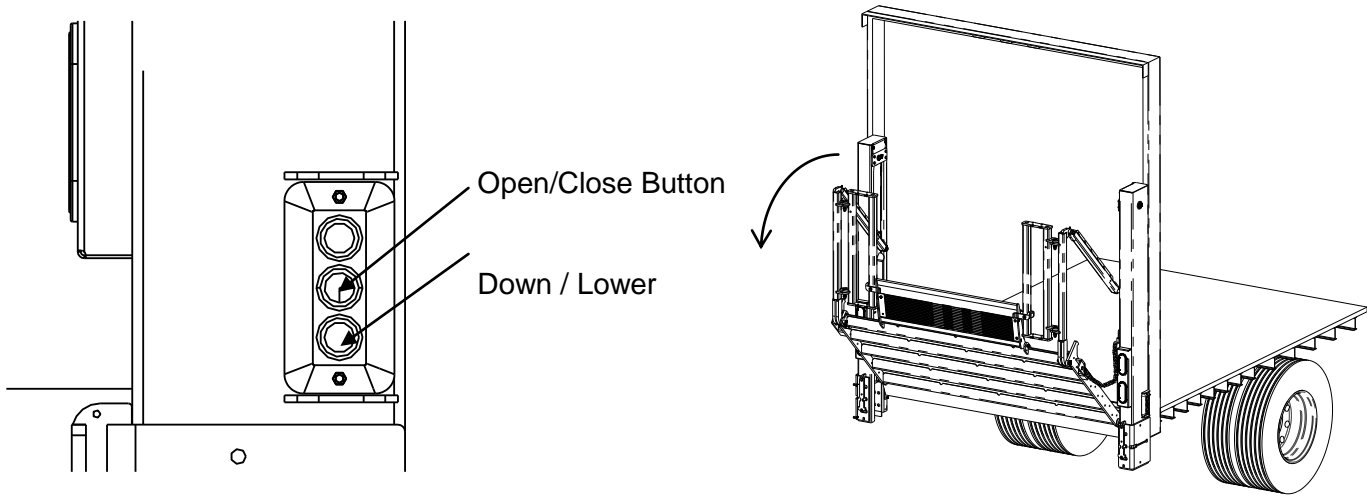

3. Lower the platform to the ground: Pushing the "DOWN" button, lower the platform to the ground. Note: for power down operation, push the down button twice (within 3 seconds).

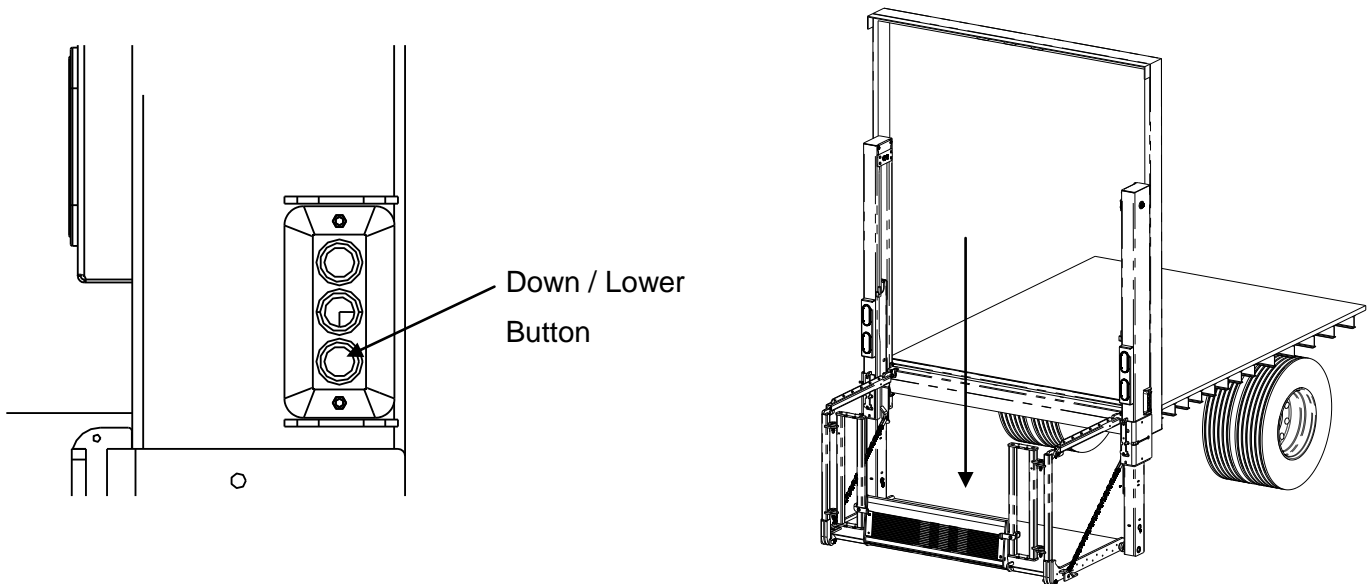

4. Raise the platform to bed level: Pushing the “UP” button, raise the platform to bed level.
5. Bleeding the system: With the platform at bed level, push the “UP” button for thirty (30) seconds. This will bypass hydraulic fluid through hydraulic poppet valves located in each of the lift cylinder pistons returning hydraulic fluid back to the reservoir via the return lines.

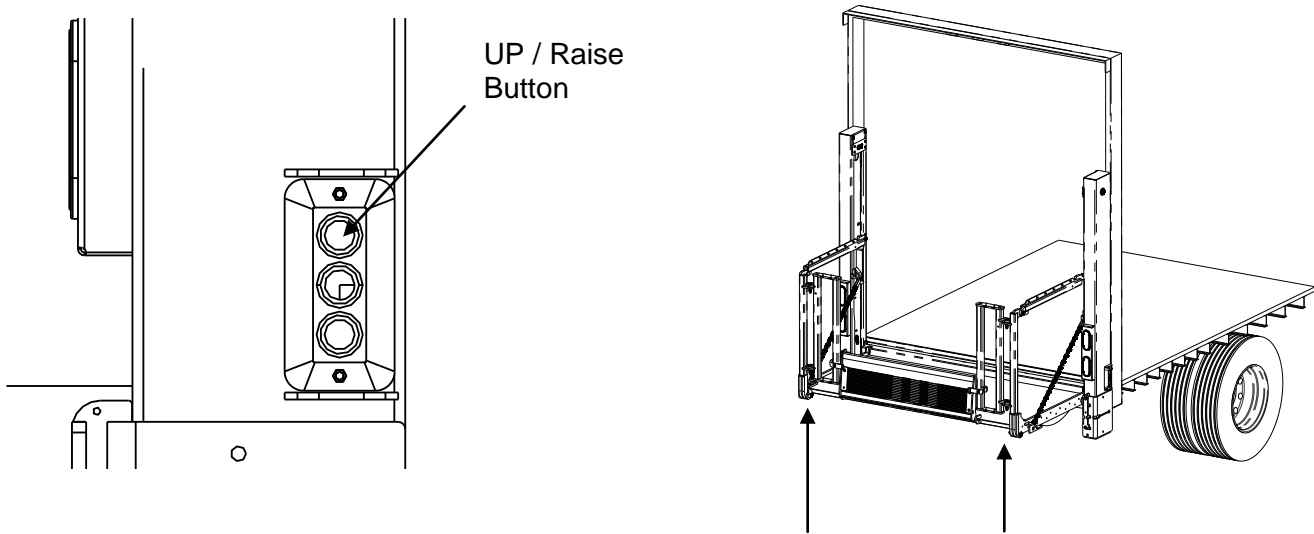

6. Closing and Storing of the Platform for transit: With the platform open at bed level use the “UP” button and “CLOSE” button together, power the platform closed.

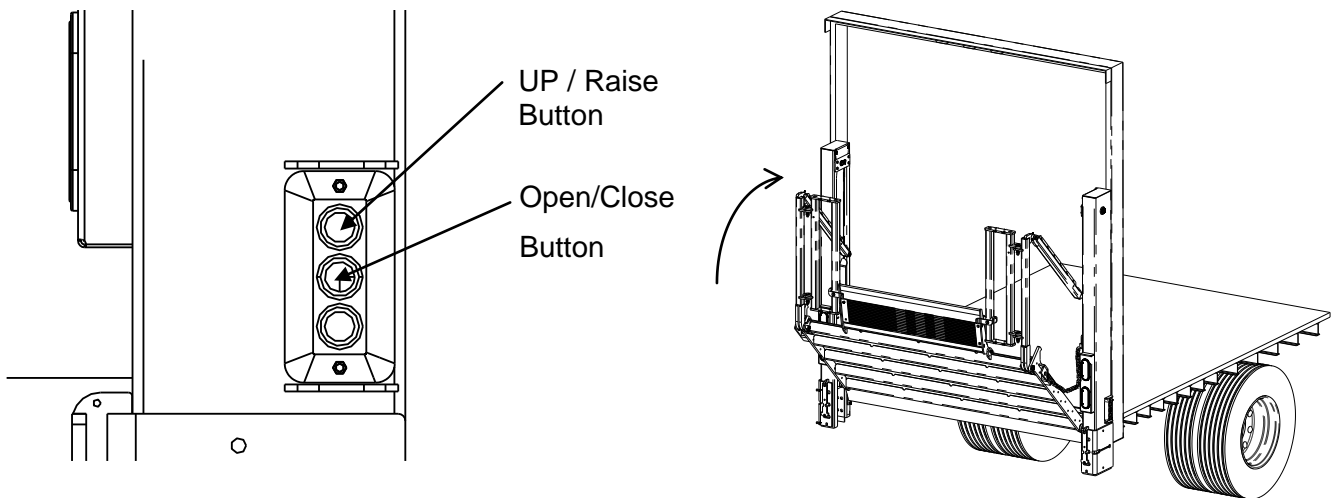

7. Lower the Platform: Using the "DOWN" button, push down twice (within 3 seconds) to power down the travel ear into travel locks. (See Illustration)

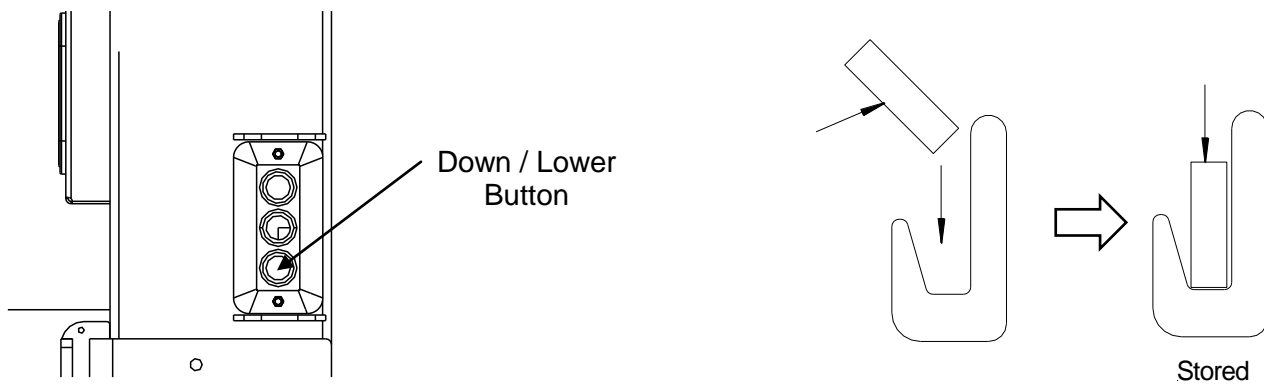

The platform should now be in stored/ transit position, as shown below.

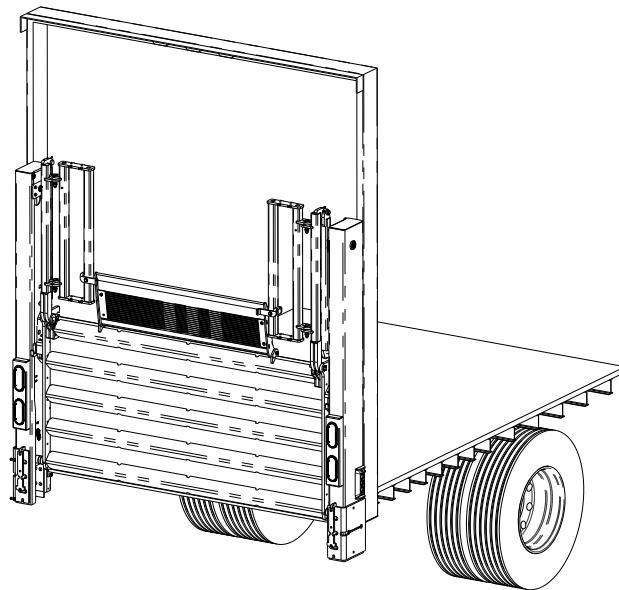

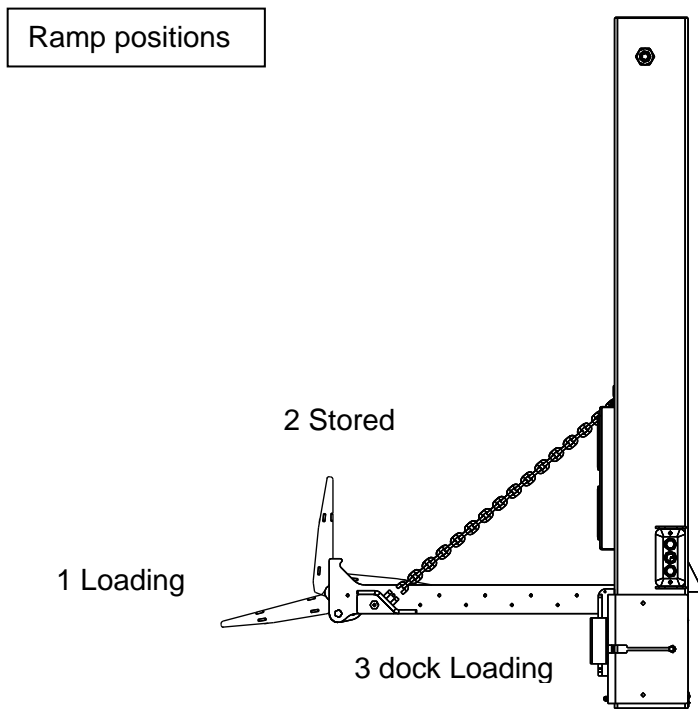

**“Loading” position (Position 1 above)** is achieved with the gate completely lowered to the ground, platform out, and the ramp out.

To open the ramp, flip the ramp latches to a vertical position. This will release the ramp

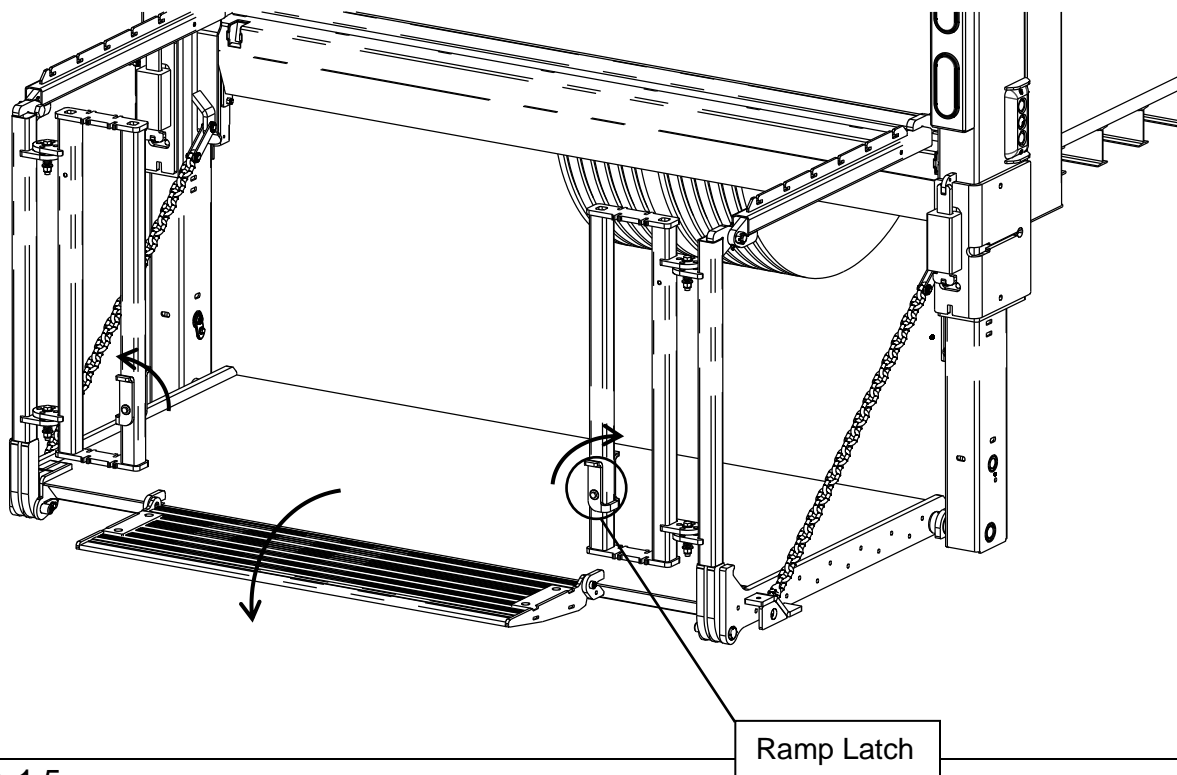



The swing doors can open in a 180° range. Lift the swing door vertically, and pivot the door in the direction you wish to open. The doors lock automatically in 3 positions.

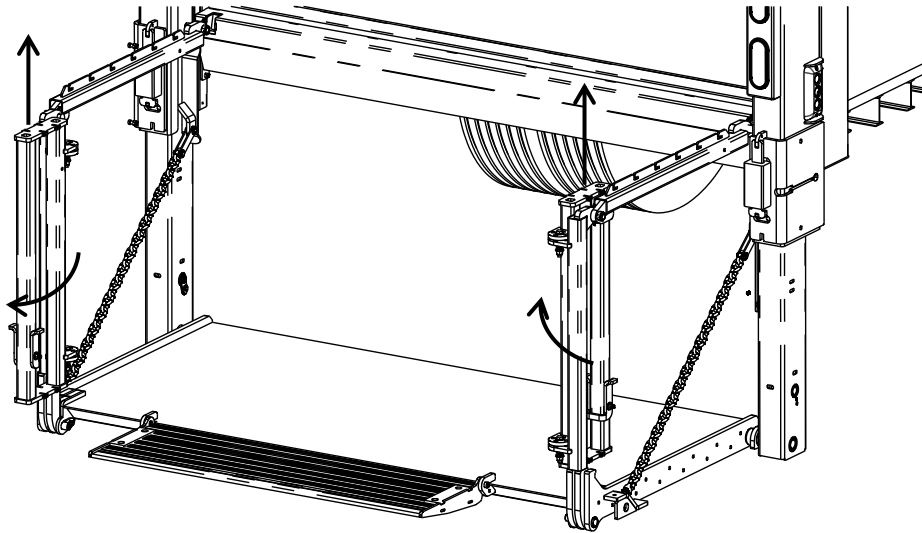

**“Dock Loading” position (Position 3)** is achieved when the platform is folded closed, and the liftgate is lowered.. The ramp should be folded over, on top of the platform.

**Operation:** From the **stored** position, raise the liftgate out of the travel lock. Press the **“Up/Raise”** button and the **“Open/Close”** button briefly to open the platform enough to clear the travel lock. Fold the ramp as shown below, if it is not already. Lower the gate until the platform passes the travel latch and is level with the vehicle floor. The platform will rest on “Dock Stops” built into the unit.

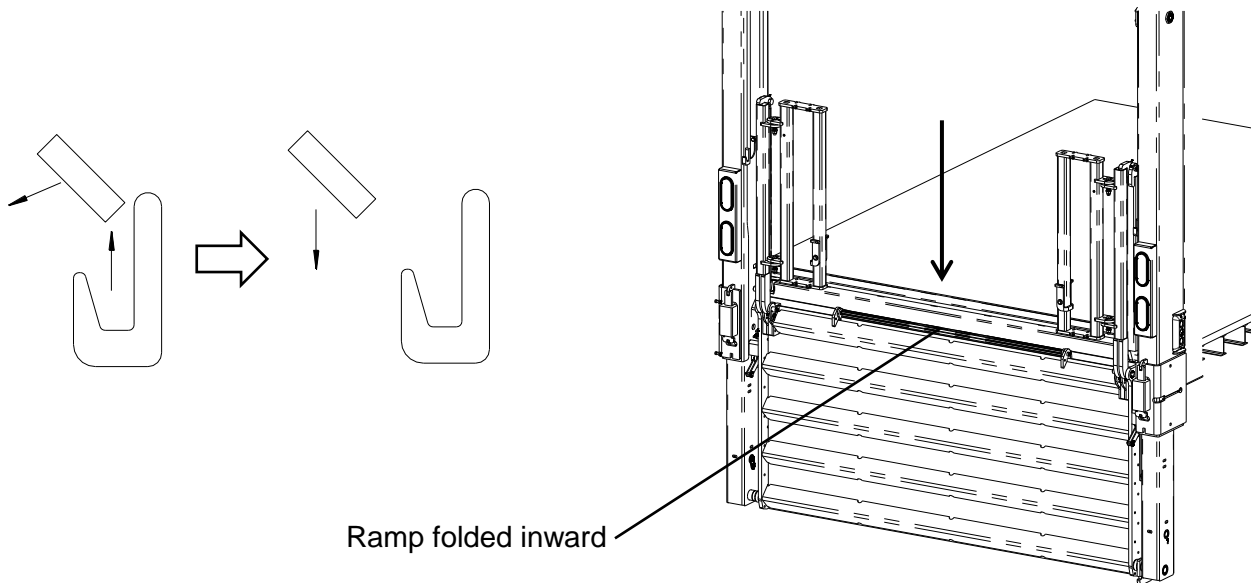

## 6.4 Loading and Unloading



### When backing up vehicle to loading dock

DO NOT hit the dock. Have a second person outside the truck directing you. Hitting the dock may cause hidden damage to liftgate components. Be sure to inspect the liftgate for damage.

## 6.5 3 Button Hand Held Control

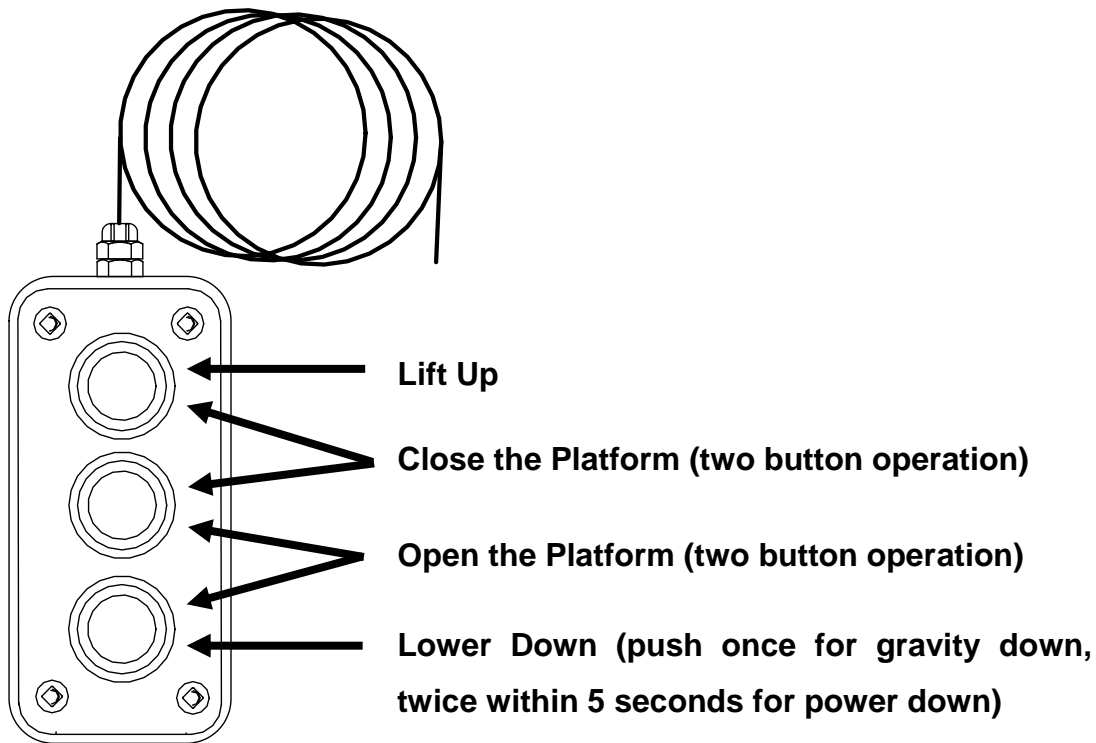

## 6.6 Cart Stops

### Aluminum Platform Cart Stops

1. Push the cart stop latch out toward the curb side. The cart stop will spring open automatically once the latch has been moved from its original position.
2. To close the cart stops, push the cart stop latch inward towards the street side. After the latch is in place close each cart stop by pushing each stop down.

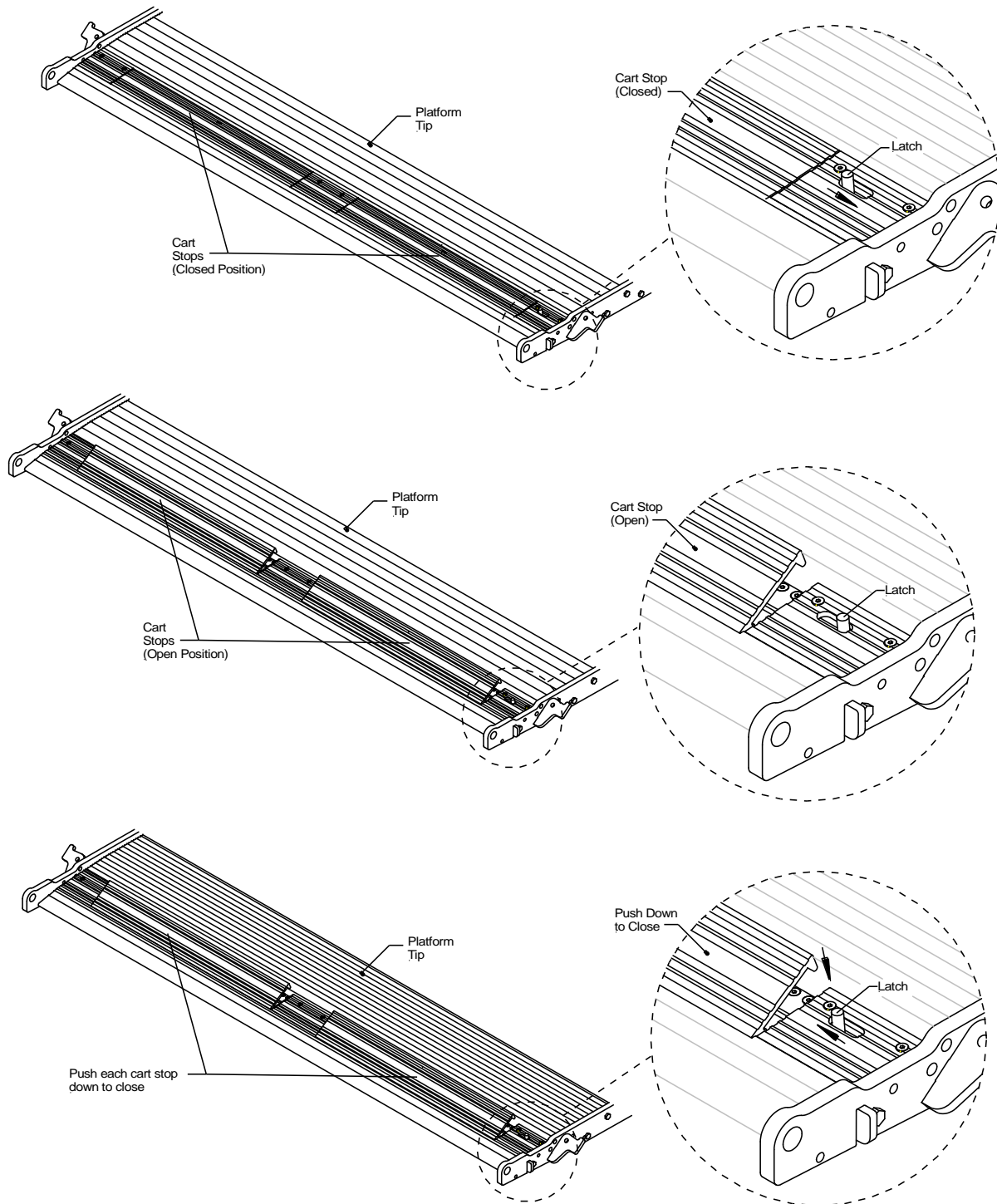

**Steel Platform Cart Stops**

1. Each cart stop is equipped with a retaining latch. Push each latch inward to open the cart stop. The cart stop will automatically spring open once the latch has been pushed.
2. To close the cart stop, push and hold each cart stop down in close position and lock each cart stop with the retaining latch.

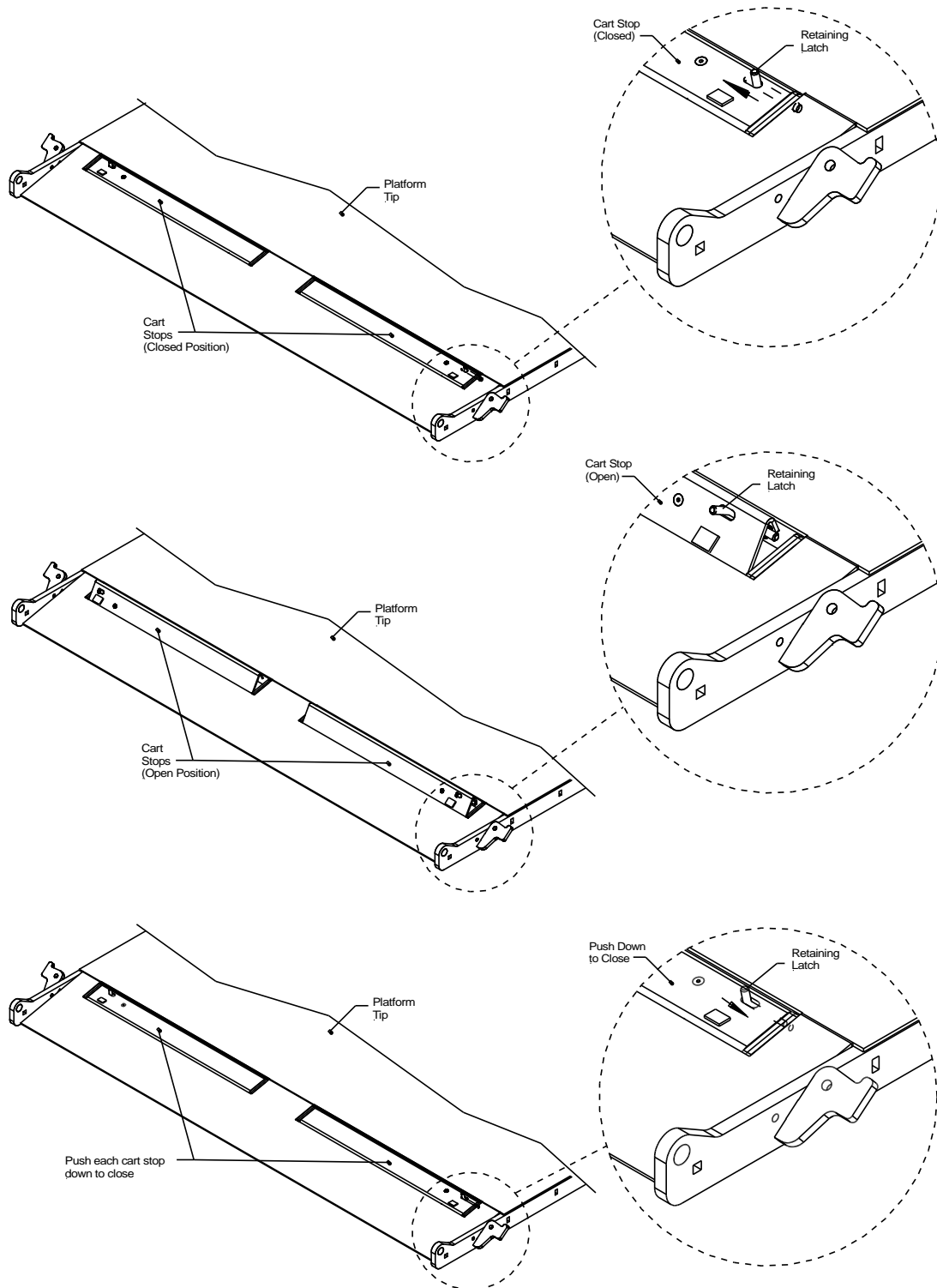

## 7 Preventative Maintenance and Quick Check

The ILD needs preventive maintenance in order to achieve maximum performance. Lubricate and inspect regularly. Also, check that there are no damaged components such as hoses, cables, controls, etc.

### 7.1 Quick Check List

1. Operate the liftgate throughout its entire cycle and check for noise and damage such as bent parts, scratches, or cracked welds.
2. Inspect all welds and fasteners that attach the mount frame to the truck.
3. Check all pin lock bolts for tight fit.
4. Visually inspect the hydraulic hoses for damage, scratches, bending or leakage. Also ensure that hoses are not fixed such that rubbing/wear on the hoses will occur- hoses should be securely fastened, not loose.
5. Inspect the cylinders for leakage and make sure the cylinder pins are secured.
6. Check the oil level when platform is down. The level should be approx. 1.5" below the top of the Oil Reservoir. PALFINGER Liftgates recommends replacing oil after the first 500 cycles, and then on a yearly basis in the fall before winter begins.
7. Check for oil leakage around the power pack. Tighten or replace components if needed. If you perform work on any hydraulic components, bleed the air out of the system by operating all functions several times to self-bleed the lift cylinders. Run the gate all the way up and down to remove air from the fluid.
8. Check all electrical connections. Clean the battery terminals.
9. Inspect all terminals on the solenoid-operated valves at the port of the cylinder. Lubricate the terminals for better protection from oxidation if needed.
10. Grease all zerks and link arms on the liftgate per the lubrication instructions and make sure that they all accept grease. It helps to operate the liftgate while you do this.
11. Test all liftgates functions, if possible with maximum loads placed according to load diagram.
12. Check the function of the pressure relief valve.
13. If you find any kind of damage that can make the operation of the liftgate dangerous, DO NOT CONTINUE TO USE THE LIFTGATE. It must be completely repaired before using. All repairs must be made by an authorized technician. Use only original spare parts. If in doubt contact your PALFINGER Liftgates distributor or PALFINGER Liftgates directly.
14. Perform the Trailer to Tractor Ground Test.



**Do not ignore any accidents or damage; it can be dangerous for you and your co-workers.**



**IMMEDIATELY REPAIR OR REPLACE FAULTY PARTS**

**7.2 Maintenance and Care**

The following “inspection and maintenance” should be performed at the recommended intervals depending on operation and amount of cycles or at the time when the unit shows any signs of damage or abuse. Remember that the secret to a long life of your PALFINGER Liftgate is to maintain it through preventive care.

The **Daily Overall Inspection** (See **Error! Reference source not found.** below) should be performed by the operator each day. You should also perform the **Lubrication Plan** according to the following pages. The **Routine Maintenance Schedule** should be performed half-yearly by an Authorized Service Center.

Your first visit to your Authorized Service Center should occur once the liftgate has been in operation for 30 days. The importance of this initial inspection is to make sure that everything is working properly during this break in period. Once this is complete, return half-yearly to your Authorized Service Center.



**Do not operate the liftgate if any issues or damages are noticed during its daily inspection. Liftgate malfunction may cause severe personal injury or death. Liftgate should be inspected IMMEDIATELY by an Authorized Service Center.**

* Recommended bases for inspection and maintenance	Depending on use	Daily	Monthly	Quarterly
cleaning	x			
general lubrication of pins and bushings				x
oil level inspection			x	
oil change	x(yearly)			
check hydraulic hoses and pipes for leaks		x		
check controls and connections				x
check pins and pin retaining bolts			x	
check batteries and connections				x
check warning labels and other safety equipment for effectiveness and visibility		x		
visual check for loose or missing parts and un-usual noise during operation		x		
check lock bolts for tightness				x
check complete function of gate		x		
check support chains			x	
check all welds			x	
Check all fasteners			x	
Lubricate grease fittings			x	

### 7.3 Trailer to Tractor Ground Test

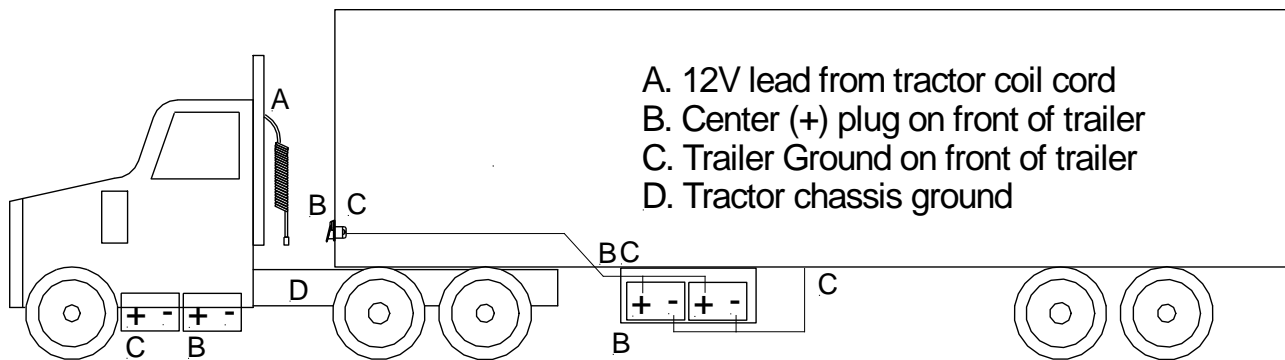

Testing of full system using a battery load tester. Start with testing each individual battery on both tractors and trailer before proceeding to check the system:

#### 1. Tractor Test:

Ground battery load tester on tractor chassis point (D)

Connect positive load tester cable on positive pole of single pole plug at end of tractor coil cord (A)

Run load test- This will test entire circuit on tractor including ground

#### 2. Trailer Test:

Ground battery load tester on trailer chassis point (C)

Connect positive cable on positive pole of single pole plug receptacle on trailer (B).

Run load test- This will test entire circuit on tractor including circuit breakers and ground between trailer batteries and trailer chassis.

#### 3. Tractor and Trailer Charging system test while connected:

Ground battery load tester on tractor chassis point (D)

Connect positive cable on positive pole of single pole plug receptacle on trailer (B).

Run load test- This will test entire circuit on tractor and trailer including ground between tractor, trailer, and circuit breaker on trailer.

A simple low amp voltage test at the front of the trailer or at the tractor will not show insufficient connections or ground problems.

## 7.4 Lubrication

Proper lubrication will help ensure a long trouble free service life for the PALFINGER ILD+. Therefore, the lift-gate should be lubricated at the same time as the truck/trailer. Grease more frequently if the lift gate is heavily used or whenever the pivot points appear to be dry. Average ILD plus use is considered 25 cycles per day or 500 cycles per month. Lubricate the gate at least every 3 months or 1500 cycles, whichever comes first.

### **CAUTION**

**DO NOT grease the “Slider Bearings” or “Columns” or “Runners”, as this will VOID your WARRANTY on the slide bearings.**

- There are 12 grease fittings to maintain.
- Use a light penetrating oil on closing aids. For power closing units, grease upper & lower pivot mounting points.

#### Bottle Gas Units:

For units with the Bottle Gas Options, there are an additional 8 grease fittings, and additional 8 locations that require light penetrating oil.

Check the oil level in the reservoir. The level should be 1.5” below the oil filler hole when the platform is opened and on the ground. Use a good quality hydraulic fluid. Change oil at least once a year, preferably in the fall before the weather gets cold. The operation of the liftgate will accumulate condensation and some dirt which can interfere with the liftgate functions.



**Standard Lubrication Locations:**

All bearing points must be lubricated in accordance with the maintenance interval.

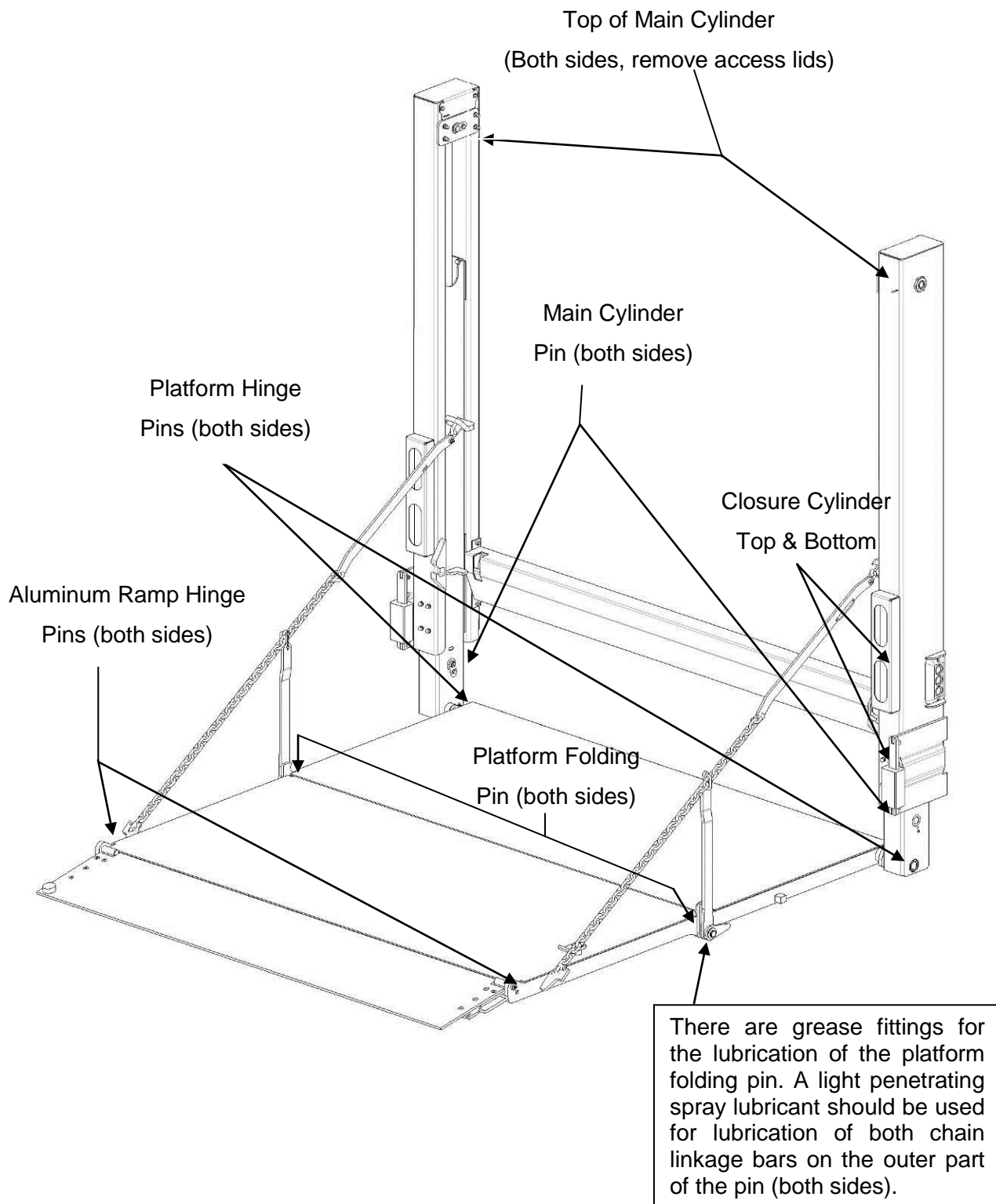

**Bottle Gas Unit Lubrication Points**

In addition to the lubrication locations shown in the previous page, Bottle Gas units require the following locations to be maintained:

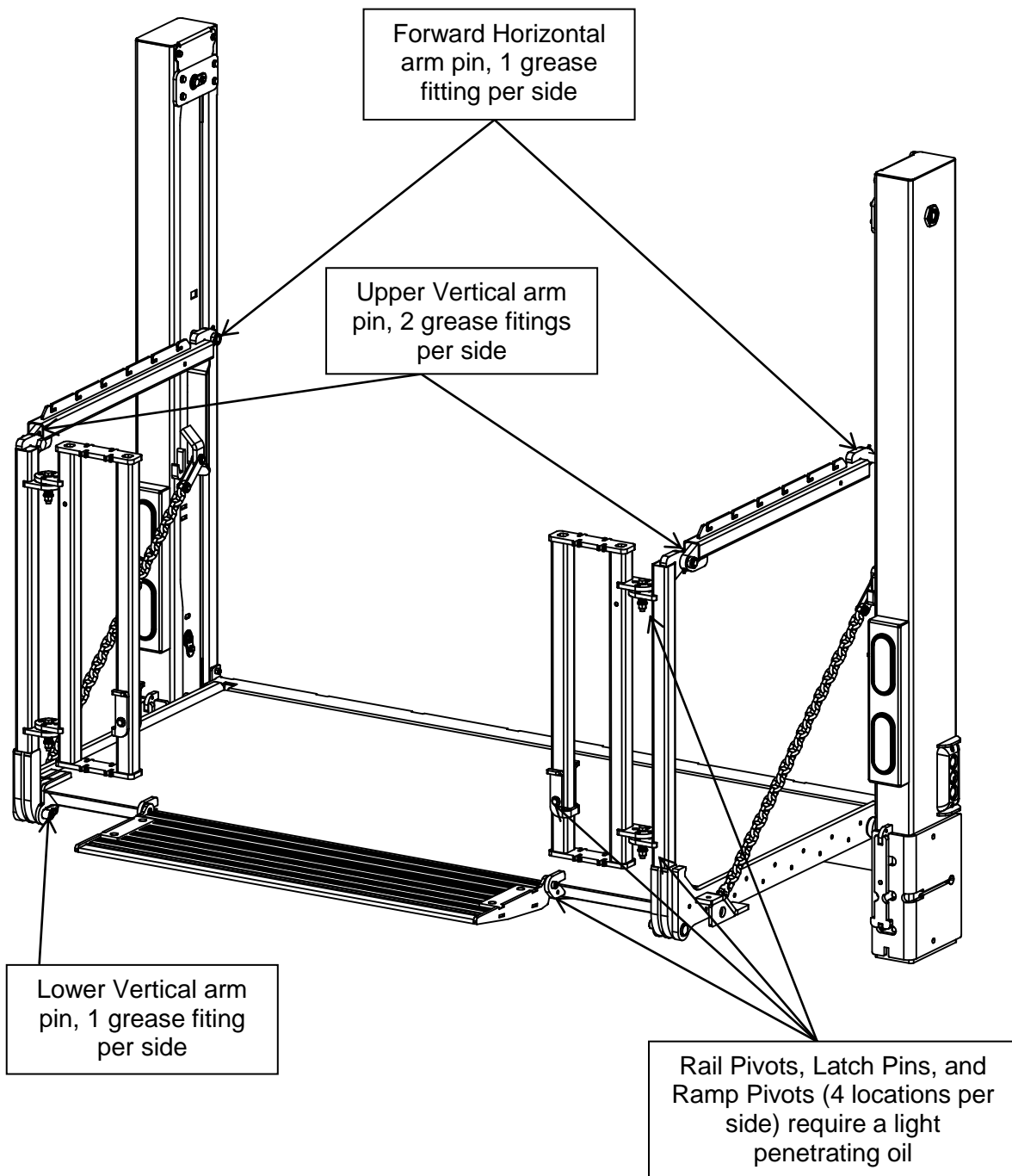

### 7.5 Checking and Changing the Oil

1. Remove the hydraulic enclosure cover..
2. Check Oil quality. If bad, follow next steps.
3. Open the platform to bed level. Remove the Oil Filler Cap.
4. Use a pump to remove the old oil. Catch the fluid in an adequate container. DO NOT disconnect any hydraulic hoses. Responsibly dispose of the old hydraulic fluid.
5. Fill up the Oil Reservoir with approved oil and secure the Oil Reservoir Cap. See next page for recommended oil. Maintain the fluid 1.5" from the oil filler hole.
6. Operate the gate through 3 cycles to disperse the oil.
7. Reinstall the oil filler cap and the hydraulic enclosure cover.

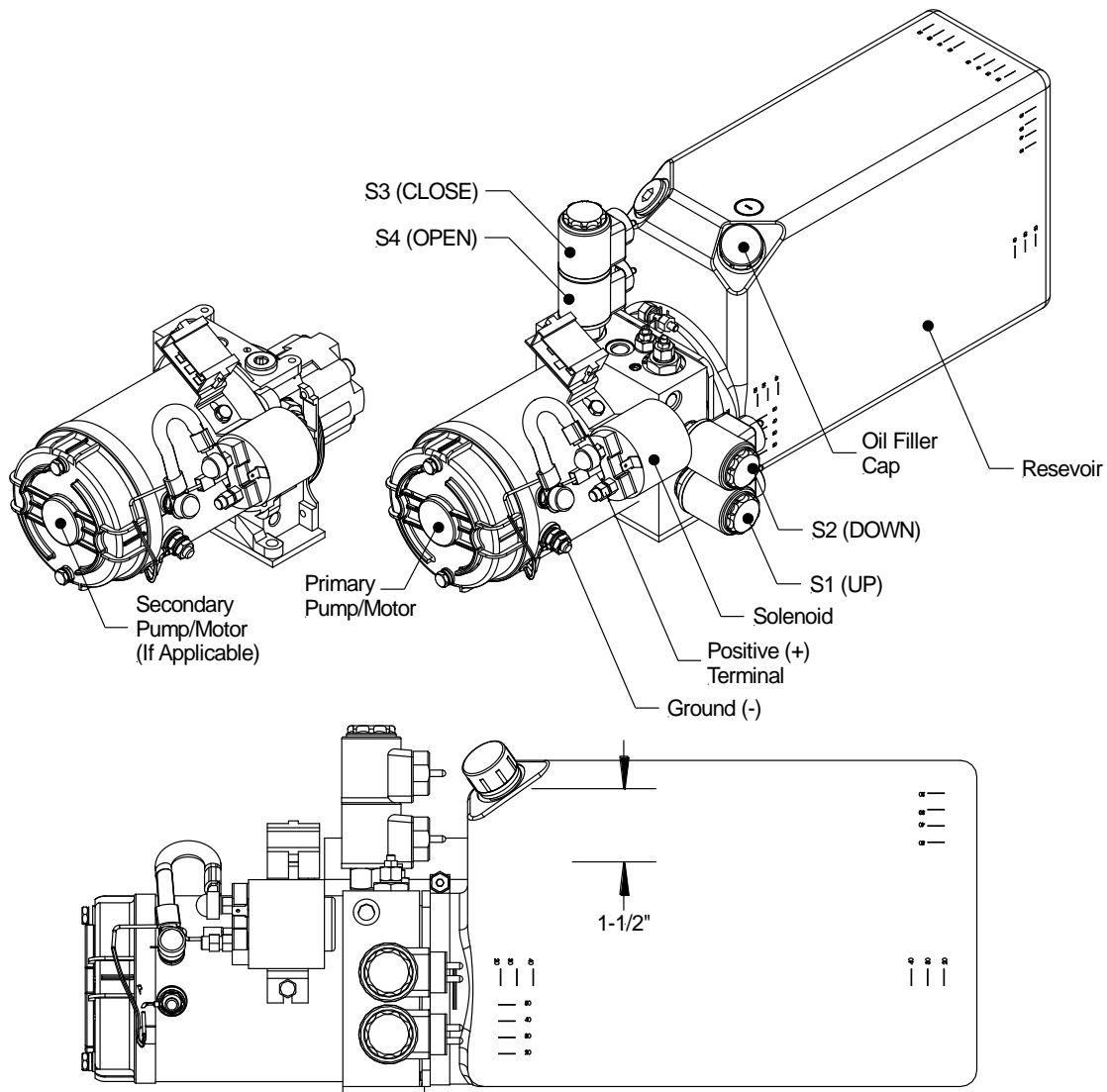

All ILD liftgates come with Hydrex MV Arctic 15 hydraulic fluid.

<b>Hydraulic Fluid Installed From Factory</b>	
<b>Property</b>	<b>HYDREX MV ARCTIC 15</b>
<i>Start Up Temperature</i>	<50°C / -58°F
<i>Operating Temperature</i>	-45°C to +23°C / -49°F to 73°F
<i>Pour Point</i>	-57°C / -71°F
<i>Flash Point</i>	128°C / 262°F
<i>Density 15°C (59°F). kg/L</i>	0.834
<i>Viscosity:</i> <i>cSt @ 40°C/SUV @ 100°F</i> <i>cSt @ 100°C/SUV @ 210°F</i> <i>cP @ -50°C (-58°F)</i>	13.0 / 69.7 4.95 / 42.5 1,310

When changing fluids, it is highly recommended to use Hydrex MV Arctic 15 fluid, however, the alternatives fluid brands listed below can be used.

<b>Alternative Fluids</b>	
<b>Temperature Range</b>	<b>Fluid Brand</b>
30° TO 150°F	EXXON UNIVIS J26
	MOBIL DTE 13M
	CHEVRON AW MV32
	ROSEMEAD MV 150 (32)
-50° TO 150°	MOBILE DTE 11
	SHELL AERO FLUID 4/41
	SHELL TELLUS 15
Extreme Cold Temperature	MIL H5606 (Military Spec.)

7.6 Decal Placement and inspection

**!** For operator's safety, all decals appearing in "Decal Kit" must be placed visibly on control side of liftgate by operator. This is typically a combination of decals on the liftgate and truck body. Please make sure to place the maximum capacity decal (D) on driver and curb side.

Decal Kit			
Decal	Qty.	Part No.	Description
A	1	ATG-OPER-ILD	Operating Instructions
B	1	ATG-OPER-ILD-BG-2	Operating Instructions (ILD-BG)
C	1	ATG-SWILD	Main Operation Switch
D	1	ATG-OPENILD	Notice for Open & Close
E	2	ATG-XXXX	Max. Capacity (please check the serial number plate to find out your specific capacity)
F	1	ATG-URGWA	Urgent warning: Elevating gate instructions
G	2	ATG-WLH	Warning: liftgate can crush
H	1	ATG-BKR	Circuit Breaker Reset (must be located at the circuit breaker)
I	1	ATG-RESET	Circuit Breaker Protection.
J	2	ATG-PLAT	Warning: Always stand clear of platform area
K	1	ATG-CAB	Liftgate Shut-Off (Place Decal next to the On-Off Switch in the Cab)
L	1	85-1114-003/85-1114-001	Conspicuity tape (If applicable)
M	1	ATG-UD	Toggle Decal, Up-Down

**OPERATING INSTRUCTIONS**

**OPENING PLATFORM FROM STOWED POSITION:**

- Turn on power to lift gate by turning on the master disconnect switch, located on the pump line, to the lift platform.
- The control operating unit (power platform) to close before operating lift gate.
- Using the "UP" button, power platform up so that it is completely out of the stowed lock.
- Using the "DOWN" button and "ON/OFF" button simultaneously, power up platform.
- Using the "DOWN" button when platform is lowered for power down (see power down with no load on platform).

**RAISING PLATFORM FROM STOWED POSITION:**

- With the platform open power platform all the way up.
- Push the "UP" button and "ON/OFF" button simultaneously to close platform.
- Using the "DOWN" button, push down lower (within 2 seconds) and power down platform until the lower lock.
- Using the "UP" button. Power platform up to lift the back case.
- Power platform up until lower lock clicks the lower lock lock.
- Use the "DOWN" button, push down (within 2 seconds), to power down lower for lift into the lower lock lock.
- Turn off power to lift gate by turning the master disconnect switch, located on the pump line, to the "OFF" position.

**POUCH WARNINGS:**

- Use on power to lift gate for turning the master disconnect switch, located on the pump line, to the "OFF" position.
- Using the "UP" button, power platform up so that it is completely out of the stowed lock.
- Using the "DOWN" button, power platform down until the platform is level with the lower lock and the back case.
- Always stand clear of platform before getting back into truck.

Decal - A

**OPERATING INSTRUCTIONS**

**Opening platform from stowed position:**

- Turn on power to lift gate by turning the master disconnect switch, located on the pump line, to the "ON" position.
- The control operating unit (power platform) to close before operating lift gate.
- Using the "UP" button, power platform up so that it is completely out of the stowed lock.
- Using the "DOWN" button and "ON/OFF" button simultaneously, power up platform.
- Using the "DOWN" button when platform is lowered for power down (see power down with no load on platform).

**RAISING PLATFORM FROM STOWED POSITION:**

- With the platform open power platform all the way up.
- Push the "UP" button and "ON/OFF" button simultaneously to close platform.
- Using the "DOWN" button, push down lower (within 2 seconds) and power down platform until the lower lock.
- Using the "UP" button. Power platform up to lift the back case.
- Power platform up until lower lock clicks the lower lock lock.
- Use the "DOWN" button, push down (within 2 seconds), to power down lower for lift into the lower lock lock.
- Turn off power to lift gate by turning the master disconnect switch, located on the pump line, to the "OFF" position.

**POUCH WARNINGS:**

- Use on power to lift gate for turning the master disconnect switch, located on the pump line, to the "OFF" position.
- Using the "UP" button, power platform up so that it is completely out of the stowed lock.
- Using the "DOWN" button, power platform down until the platform is level with the lower lock and the back case.
- Always stand clear of platform before getting back into truck.

Decal - B

**OPERATING INSTRUCTIONS**

Close liftgate from stowed position:

- Turn on power to lift gate by turning the master disconnect switch, located on the pump line, to the "ON" position.
- The control operating unit (power platform) to close before operating lift gate.
- Using the "UP" button, power platform up so that it is completely out of the stowed lock.
- Using the "DOWN" button and "ON/OFF" button simultaneously, power up platform.
- Using the "DOWN" button when platform is lowered for power down (see power down with no load on platform).

**RAISING PLATFORM FROM STOWED POSITION:**

- With the platform open power platform all the way up.
- Push the "UP" button and "ON/OFF" button simultaneously to close platform.
- Using the "DOWN" button, push down lower (within 2 seconds) and power down platform until the lower lock.
- Using the "UP" button. Power platform up to lift the back case.
- Power platform up until lower lock clicks the lower lock lock.
- Use the "DOWN" button, push down (within 2 seconds), to power down lower for lift into the lower lock lock.
- Turn off power to lift gate by turning the master disconnect switch, located on the pump line, to the "OFF" position.

**POUCH WARNINGS:**

- Use on power to lift gate for turning the master disconnect switch, located on the pump line, to the "OFF" position.
- Using the "UP" button, power platform up so that it is completely out of the stowed lock.
- Using the "DOWN" button, power platform down until the platform is level with the lower lock and the back case.
- Always stand clear of platform before getting back into truck.

Decal - C

**NOTICE**

OPEN AND CLOSE LIFTGATE WITH PLATFORM FULLY RAISED

ATG-OPENILD

Decal - D

**CAUTION**

Maximum Load Capacity  
**xxxx pounds.**

Center load on platform to avoid personal or property damage.

ATG-XXXX

Decal - E

**NOTICE**

ELECTRICAL SYSTEM IS PROTECTED BY A RESETTABLE CIRCUIT BREAKER. SEE OWNER'S MANUAL AND DECAL LOCATED AT THE BATTERY.

ATG-RESET

Decal - I

**NOTICE**

ELECTRICAL SYSTEM PROTECTED BY RESETTABLE CIRCUIT BREAKER

TO RESET - PUSH RESET TAB IN

ATG-BKR

Decal - H

**NOTICE**

UP  
DOWN

ATG-UD

Decal - M

**URGENT WARNING**

BEFORE OPERATING LIFT, BE SURE YOU UNDERSTAND:

- Improper operation of this lift gate can result in serious personal injury. Do not operate unless you have been properly instructed, trained, and are familiar with the operating instructions. If you do not have a copy of the instruction manual, please obtain it from your employer, distributor or dealer, or appropriate, before you attempt to operate the lift gate.
- Be certain the vehicle is properly and securely loaded before using the lift gate.
- Always inspect this lift gate for maintenance or damage before using it. If there are signs of repairs, malfunctions, damage to vital parts, or if any safety devices are missing, do not use the lift gate. Do not obstruct your own repairs, unless you are specifically trained.
- Do not overload. See the lift, literature and/or rating label on the unit for the rated load. Remember that this lift applies to both raising and lowering operations.
- Each load should be placed in a stable position as near as possible to the center of the platform.
- Never allow yourself, a helper, or a bystander to stand in a position where an unstable load might fall on them. Do not allow any part of your or your helper's body to be placed under, through, or around any portion of the raising lift gate, or in a position it would pass through between any parts when the lift gate is lowered.
- This lift gate is intended for loading and unloading of cargo only. Do not use this lift gate for anything but its intended use. The lift gate is not equipped with a back up system to prevent falling in the event of a failure.

ATG-URGWA

Decal - F

**WARNING**

LIFTGATE HAZARDS CAN RESULT IN CRUSHING OR FALLING

KEEP HANDS AND FEET CLEAR OF PINCH POINTS

IF RIDING LIFTGATE, MAKE SURE LOAD IS STABLE AND FOOTING IS SOLID

HEAD AND UNDERSTAND ALL INSTRUCTIONS AND WARNINGS BEFORE USE.

ATG-WLH

Decal - G

**WARNING**

ALWAYS STAND CLEAR OF PLATFORM AREA

ATG-CAB

Decal - J

**NOTICE**

LIFT GATE SHUT-OFF TO BE TURNED OFF WHEN LIFT IS NOT IN USE

ATG-SWILD

Decal - K



Decal - L

You may obtain free replacement decals by contacting us at 888-774-5844 within the U.S. and Canada. Please have your liftgate model # and serial # ready.

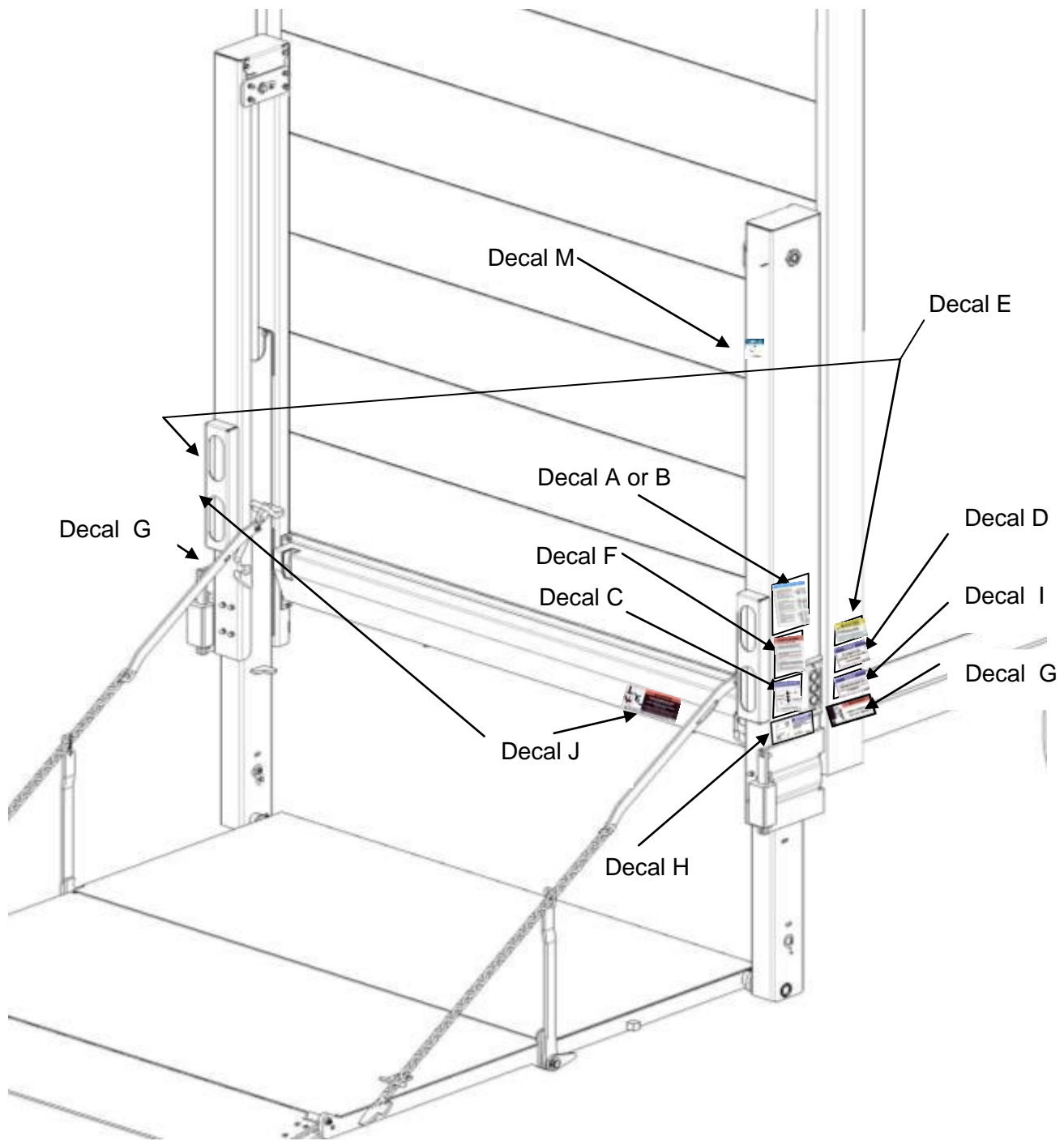

**NOTICE**

It is the installer's responsibility to determine the proper application of the Conspicuity tape, and to ensure that the vehicle or trailer meets DOT and federal lighting regulations. The following diagram is a guideline for placement on trailers over 80" wide and GVWR of 10,000 Lbs or more. This document is not intended to replace published agency regulations, and it is strongly recommended that the installer refer to the Code of Federal Regulations (CFR) which can be viewed at <http://ECFR.gpoaccess.gov>.

**Requirement 2:**  
On each corner: Two 12" long white reflective pieces, place adjacently to one another as close to the upper corner of the trailer as possible

**Requirement 1:**  
Red/white reflective tape applied across the entire width of the trailer placed at an appropriate height H from the ground

**Requirement 3:**  
Red/white reflective tape applied across the entire width of the rear underride protection device.  
**Note:** Not required if no underride protection is equipped

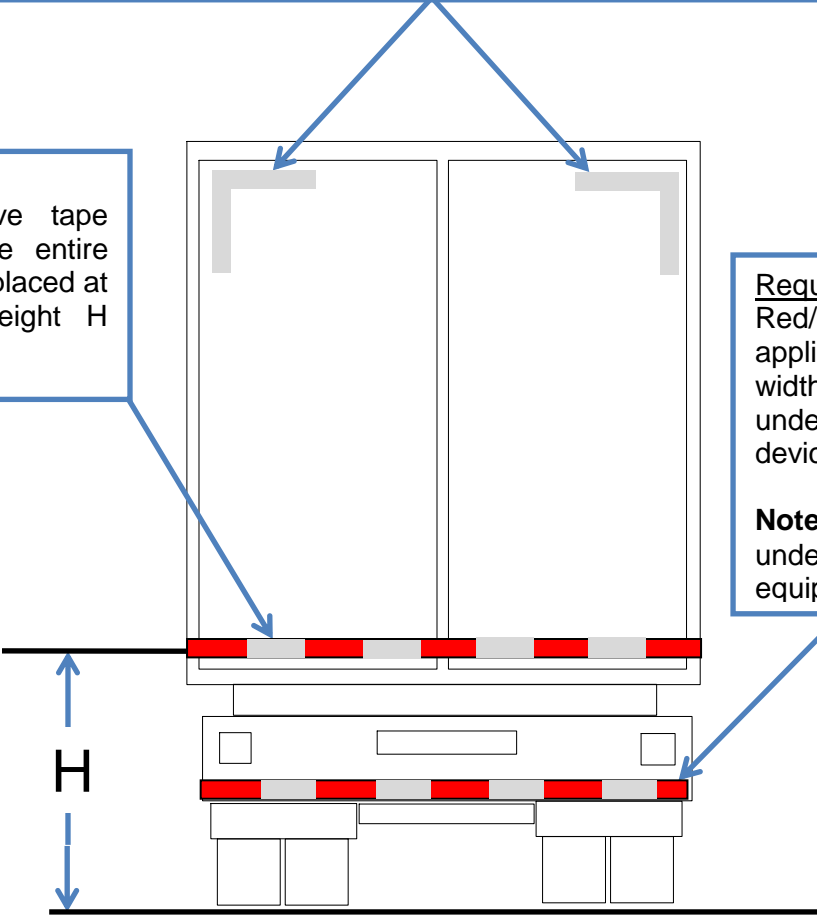

**H Dimension:**  
15" < H < 60" from ground to center of tape

## 8 Troubleshooting

### **⚠ WARNING**

Dangerous injuries are possible from objects such as tools short circuiting main battery connections. Be sure that you are working in a safe environment.

### **NOTICE**

Change oil after working on hydraulic unit (removal of valves, opening of cylinder etc). There is a possibility of injury if somebody other than an authorized technician works on the electrical system!

### 8.1 Basic Function Checks

#### 8.1.1 LIFTGATE is completely DEAD (No Clicking or Movement at all)

1. Check the cab shut off switch

Turn on cab switch, located in the cab next to the steering wheel. Location may vary by model and year of truck.

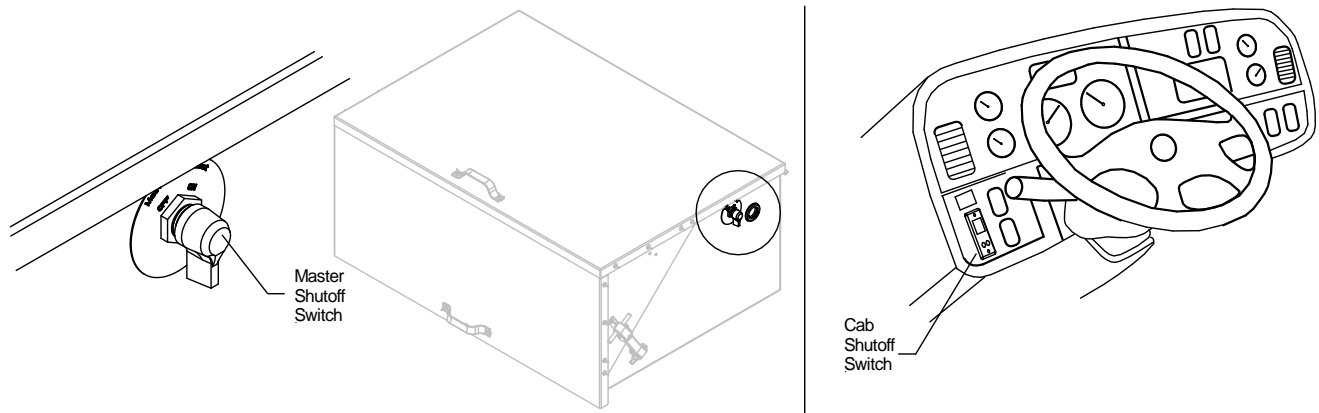

On trailer units, you will find a toggle switch near rear curb side corner post to activate the gate.



2. Check the circuit breaker at the main batteries

Every truck has a circuit breaker on top of the main battery. Trailers and some trucks are equipped with an auxiliary battery kit as shown in the pictures below ("Truck Battery" and "Auxiliary Battery"). If circuit breaker reset arm is popped out, push it back in as shown on the decal ATG-BKR next to your breaker or on battery box lid.

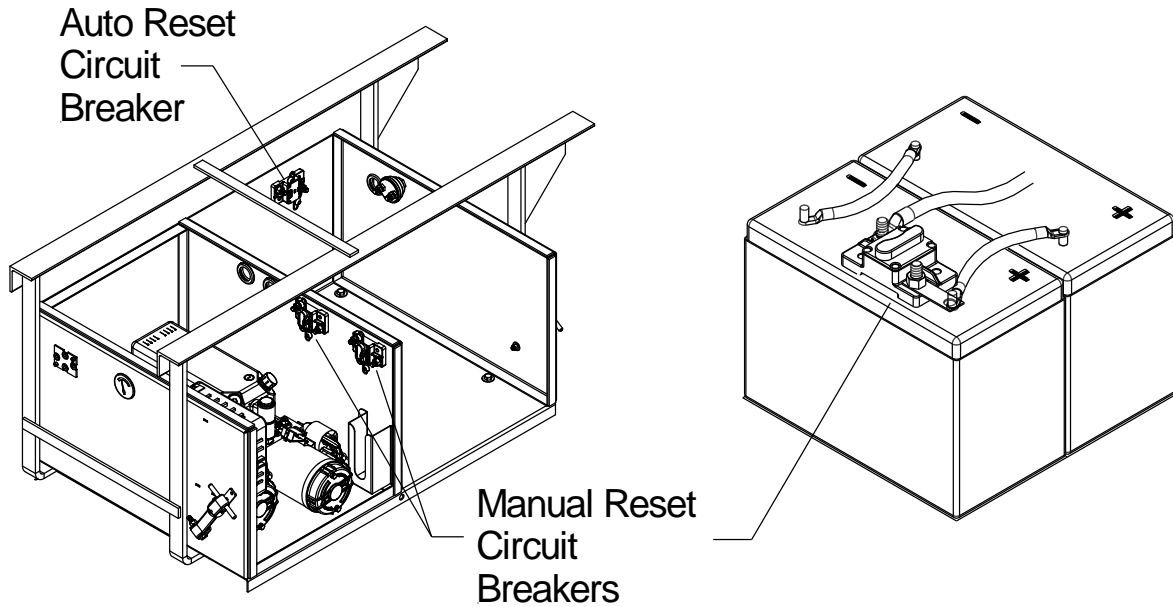

Circuit Breakers at Hydraulic Enclosure

Circuit Breaker at Vehicle Batteries

3. Are the vehicle batteries charged?

Check batteries and the truck/trailer charging system. Start truck and run engine in fast idle for charging the batteries. If the liftgate starts working, recharge batteries.

4. check the fuse at the power pack.

Remove the Housing Cover. After opening the Cover you will see the fuse in front of the Power Pack, as shown in the following picture. Check for burned fuse and replace it with the same type. See **Error! Reference source not found.** on the next page.



DO NOT use higher amperage fuse.

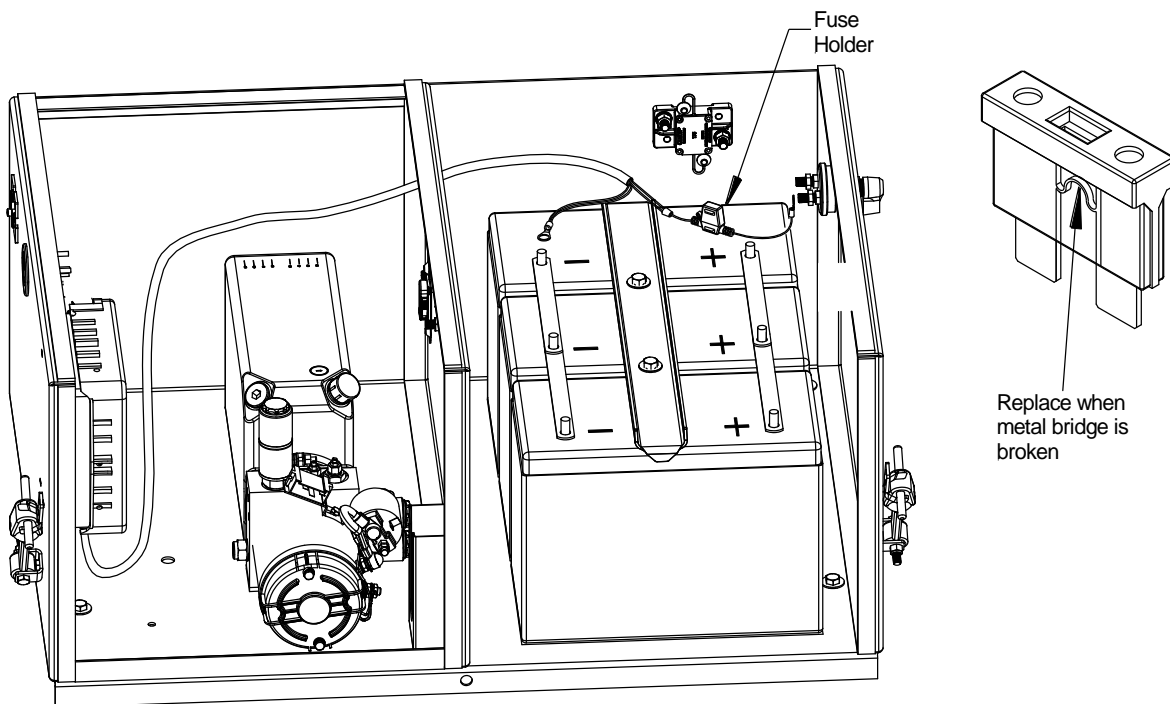

5. Is the connection to ground in power pack OK?

Is the ground connection from the tail lift to vehicle OK?

6. Check the oil level in the power pack reservoir.

7. Are there any damages on mechanical or electrical parts (such as damaged cables)?

### 8.2 Battery Cable Connections

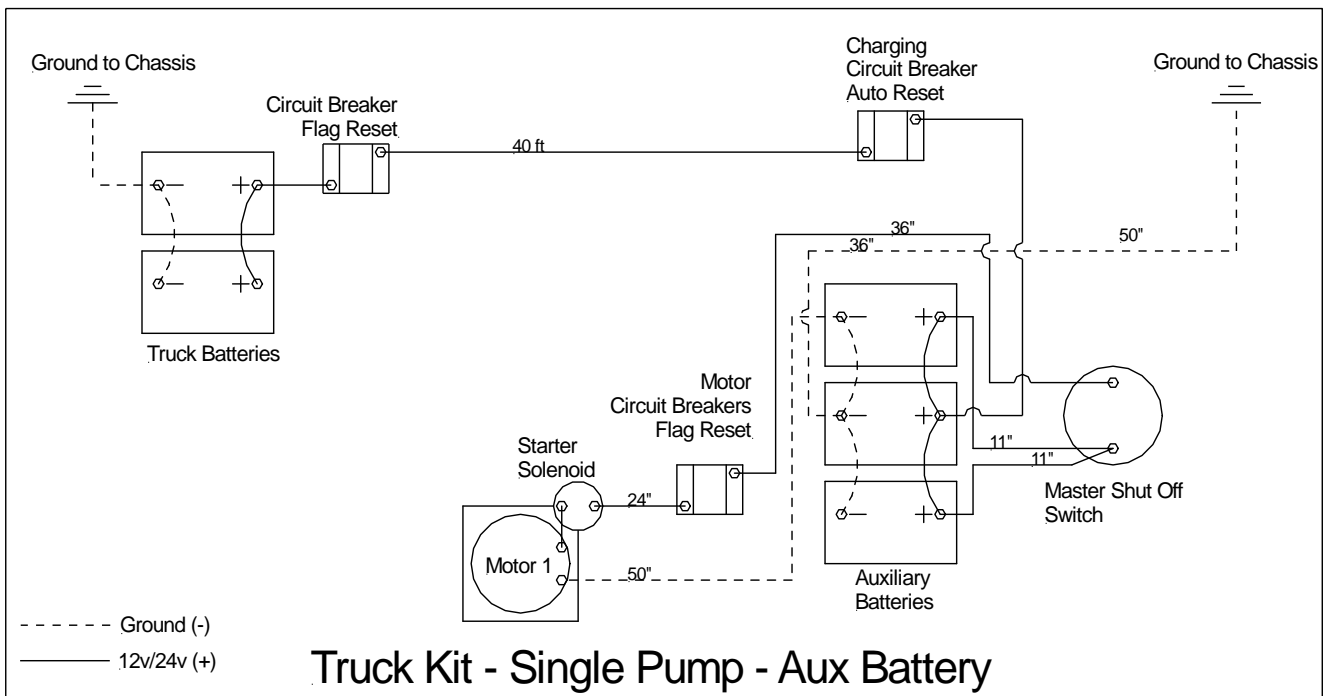
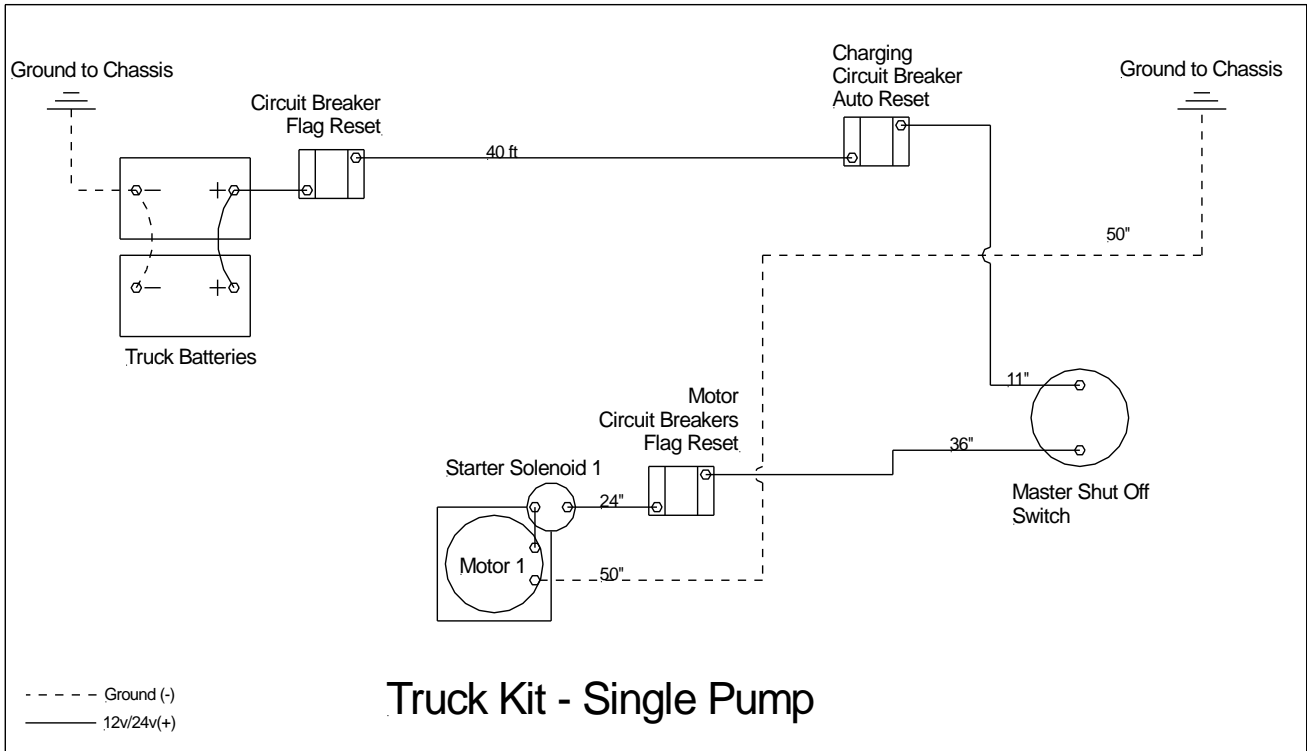

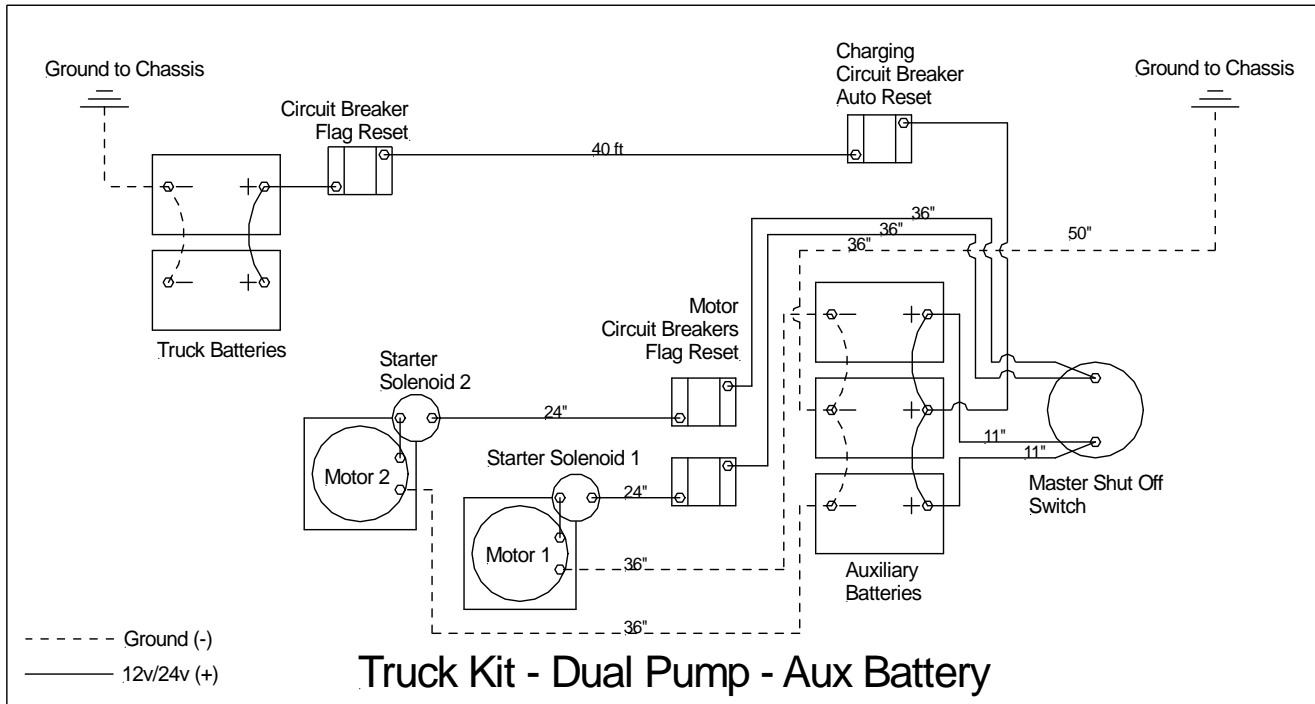

**Battery Connections: Auxiliary Battery Trailer Kit**

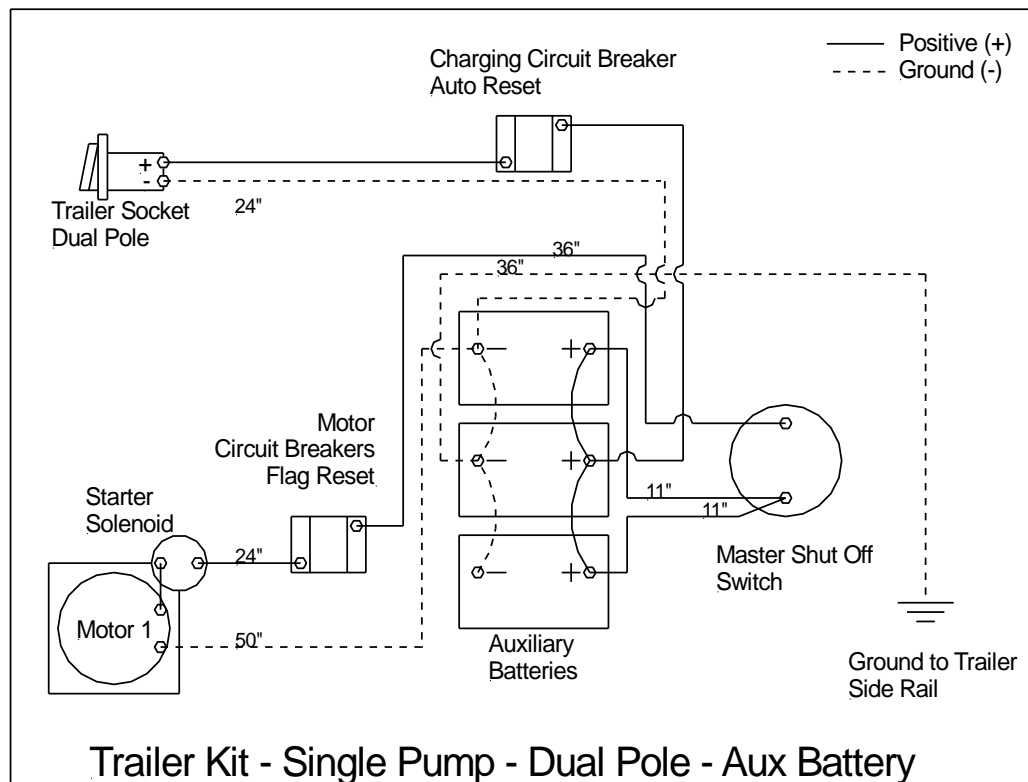
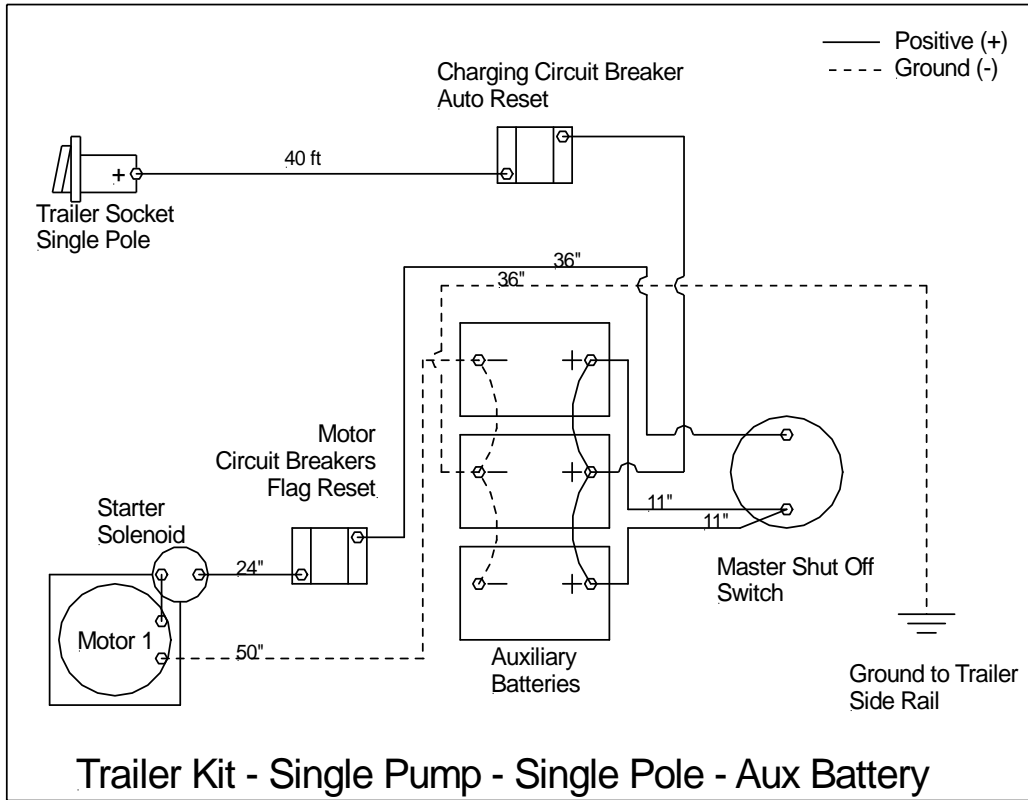

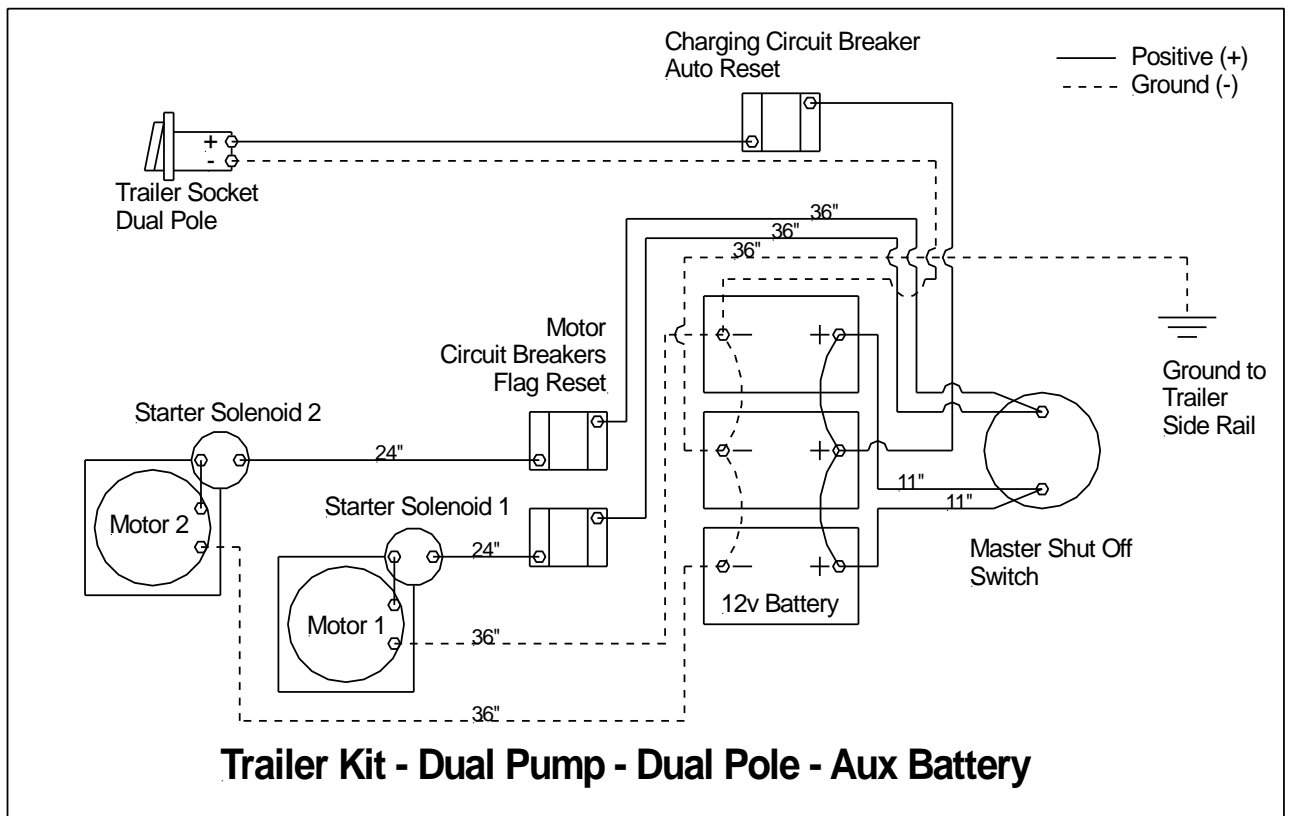
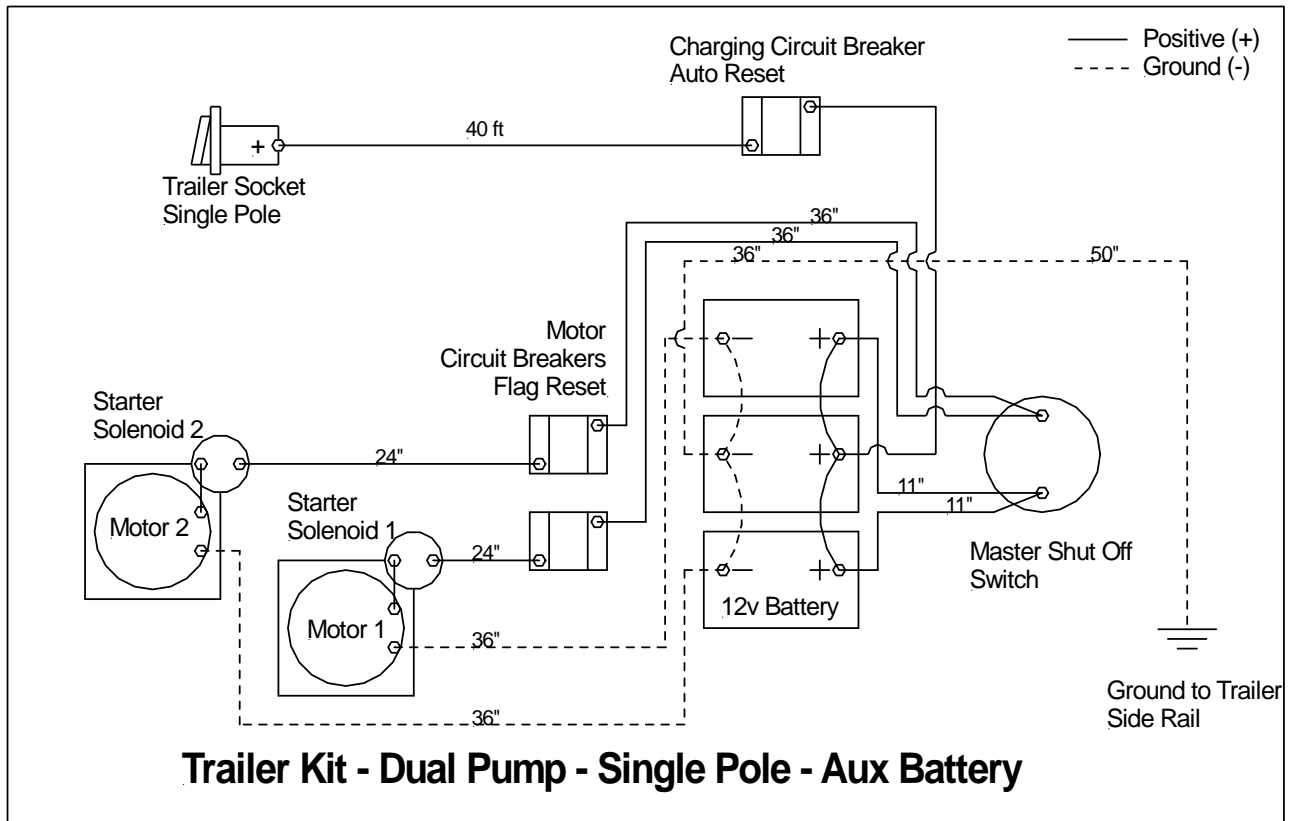

### 8.3 Electrical Schematic Overview

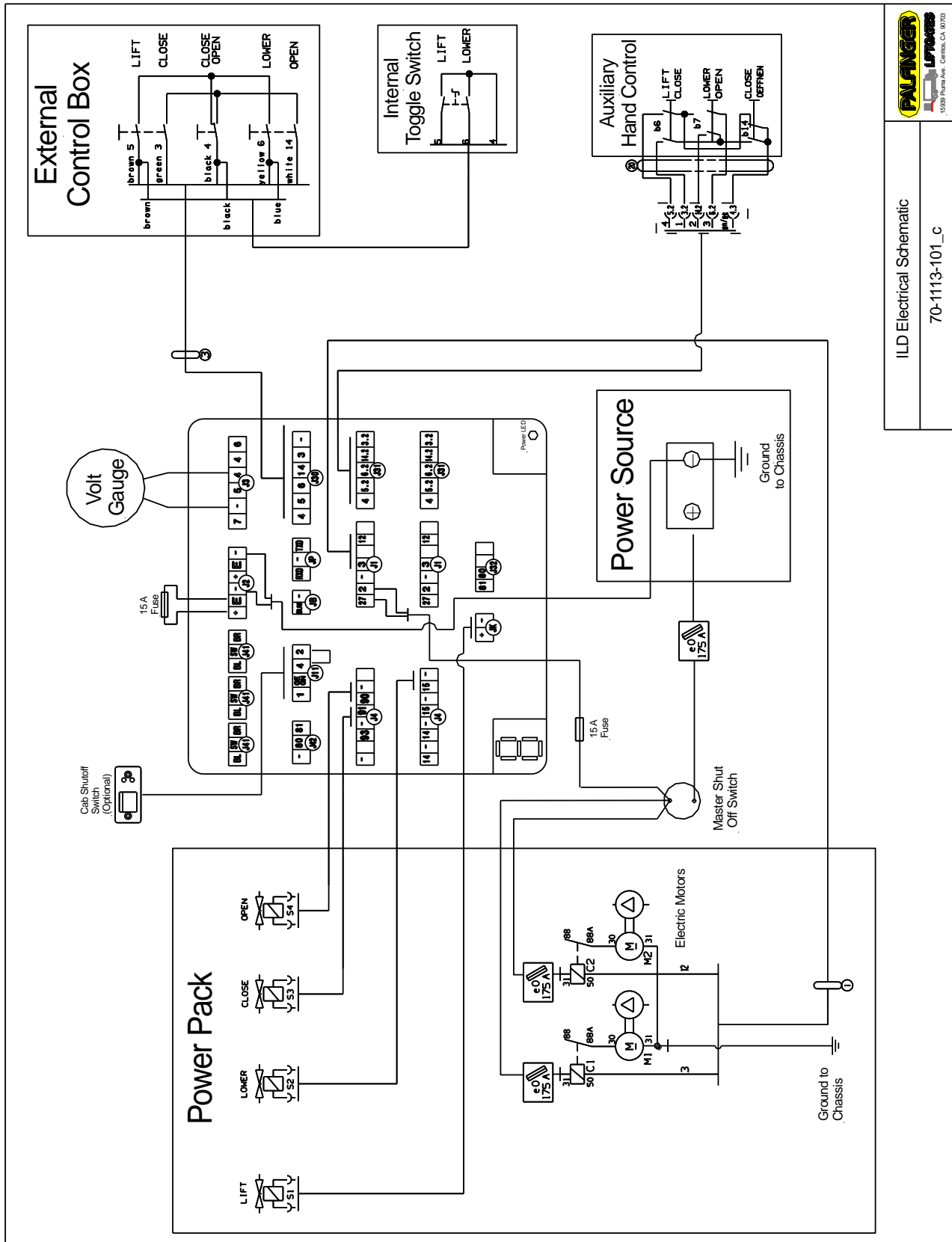

8.4 Control Board Codes

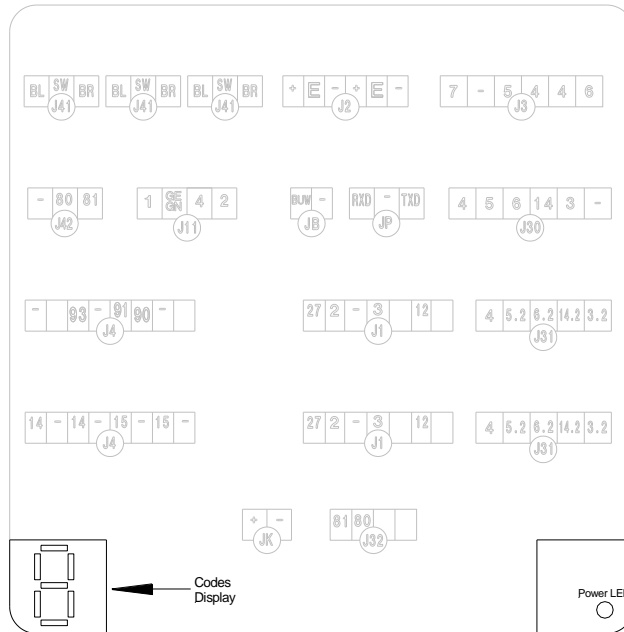

Control Board Code	Description	Reset
0	System ok / Cab switch off, (or missing bridge J11/2<->4)	
1	System ok / Cab switch on, (or bridge J11/2<->4)	
2	Low voltage – start truck engine, charge battery	Cab switch: off/on (or disconnect bridge J11/2<->4)
3	Defective or missing tilt switch B13 at lift arm	Automatically when the valves are back to normal
4	Defective or missing tilt angle sensor B15 at lift arm	Automatically when the valves are back to normal
5	Defective or missing tilt angle sensor B15 at platform	Automatically when the valves are back to normal
6	Warning lights shorted	Cab switch: off/on (or disconnect bridge J11/2<->4) or close tail lift
7	Short in cab switch / on-off-switch or aux port	Cab switch: off/on (or disconnect bridge J11/2<->4) or close tail lift
8	General short in electric wiring	Cab switch: off/on (or disconnect bridge J11/2<->4) or voltage interruption MBB control
9	Defect at motor solenoid detected during lifting	Automatically when the valves are back to normal
A	Voltage V02 (J1 pin 2) is missing, defective fuse?	Replace the fuse
b	Defect at opening, valve (S3/S4) or motor relay detected during opening	Automatically when the valves are back to normal
c	Defect at motor solenoid or S5 valve detected during closing	Automatically when the valves are back to normal
d	Defect at lowering valve (S1/S2) or S5 valve detected	Automatically when the valves are back to normal
E	Emergency program (all sensors are bypassed). Activation by: Press Open + Lower + Extra Button > 10 seconds	Cab switch: off/on (or disconnect bridge J11/2<->4)
P	Diagnosis mode activated	Removing service connector



8.5 Hydraulic Schematic

# HYDRAULIC SCHEMATIC ILD+

( Serial# up to PD 10178 )

TANDEM PUMP/MOTOR  
OPTIONAL: 3500, 4400  
STANDARD: 5500, 6600

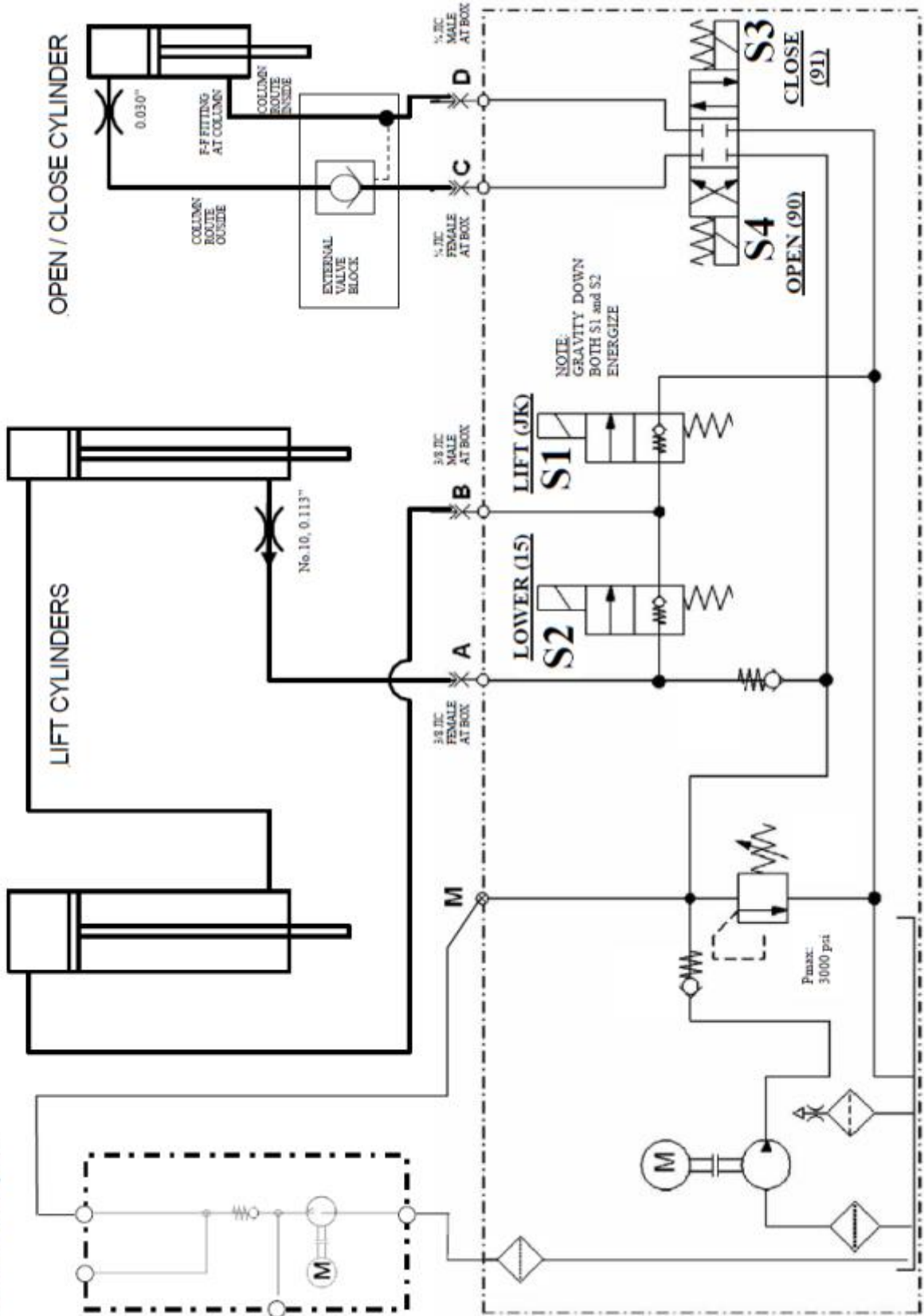

8.6 Hydraulic Schematic (Pilot Check)

**HYDRAULIC SCHEMATIC ILD+**  
( Serial# PD 10179 through xxxxxxx )

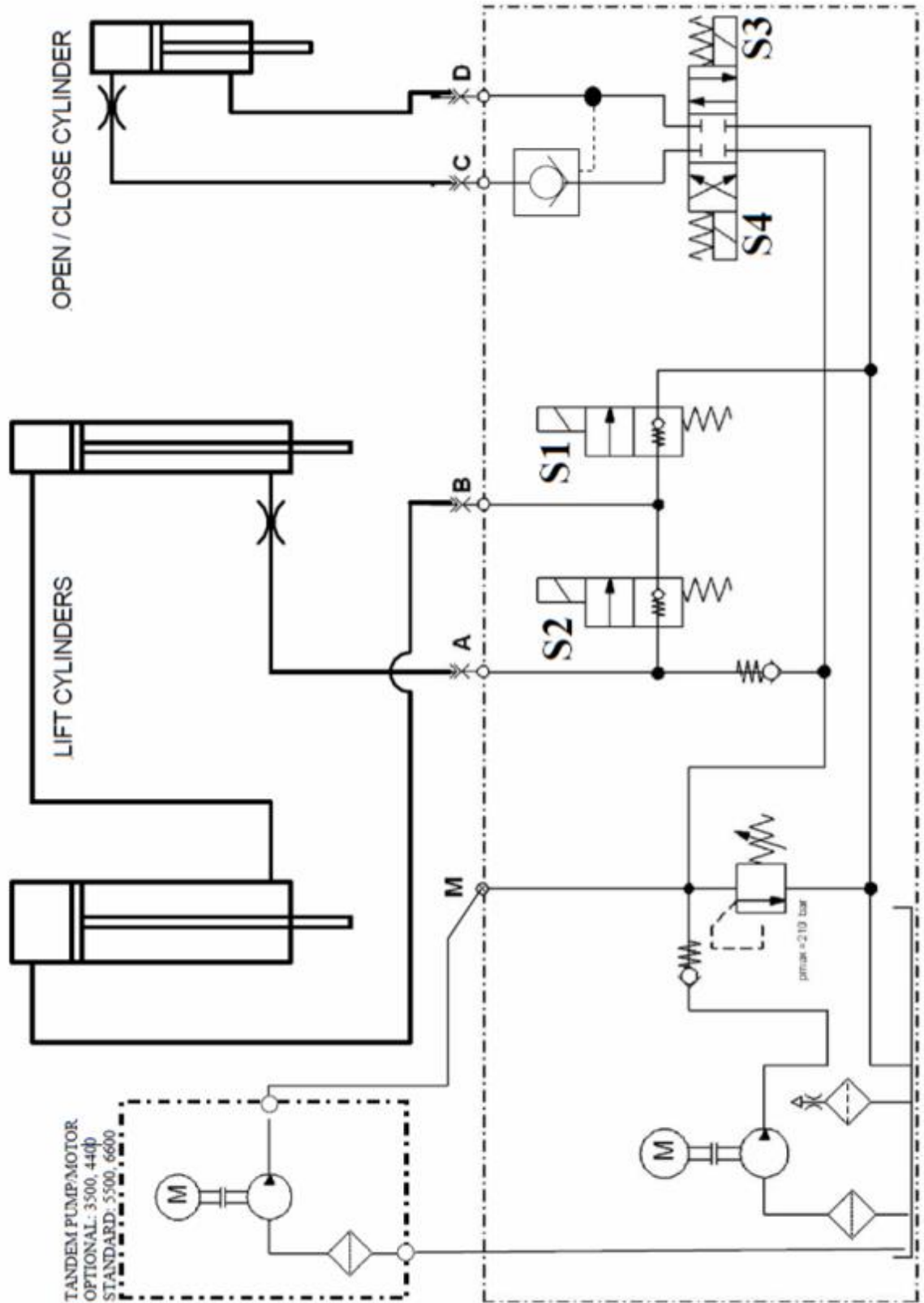

8.7 Hydraulic Schematic (Pilot Check and Bypass)

**HYDRAULIC SCHEMATIC ILD+**  
( Serial# XXXXXXX and higher )

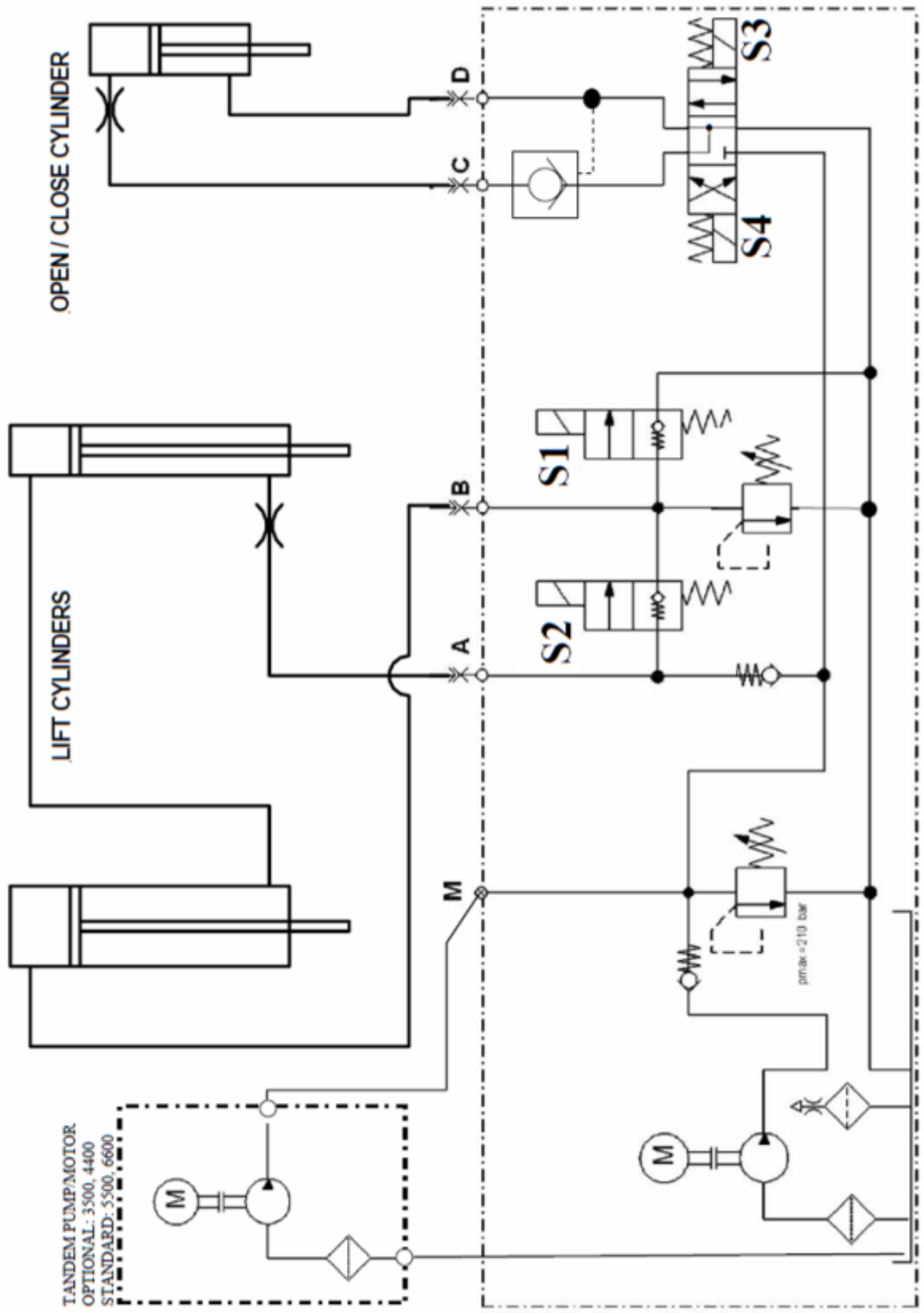

## 9 **Required Information for Ordering Spare Parts and Repairs**

### 9.1 **Ordering Spare/Replacement Parts**

In order to assure quick delivery of replacement parts, always state the following information when making orders:

1. Liftgate model & serial number.
2. Designation and number of the spare part in accordance with the spare parts list.
3. Designation and number marked on the individual component (if available).

### 9.2 **Repairs**

Parts sent to PALFINGER Liftgates to repair must be accompanied by a letter (in separate cover) giving details and scope of the repairs required.

## 10 Warranty

PALFINGER Liftgates provides warranty as part of its conditions of delivery.

All part deliveries will initially be billed. PALFINGER Liftgates then issues credit for all or part of the invoiced sum, when PALFINGER Liftgates has been able to determine that the warranty claim is justified as defined by its warranty conditions. PALFINGER Liftgates does this by inspecting the defective parts, which are sent back to PALFINGER Liftgates freight-prepaid as well as the written description of the problem which must be filled out in full.

The parts that are sent back to PALFINGER Liftgates, marked with serial number and address, become PALFINGER Liftgates' property if the warranty claim is accepted.

All warranty claims must be received **within 30 days** of repair or replacement. Including the following information:

1. Liftgate model.
2. Liftgate serial number.
3. Description of problem.
4. Itemized bill of repair with breakdown of number of hours to perform warranty work and labor charges per repair.
5. Parts used for repair with PALFINGER Liftgates part number.
6. RMA#.
7. Contact at PALFINGER Liftgates, if applicable.

Model	Pump and Motor	Cylinders	Hardware	Control System	Hydraulic
ILD Plus	3 yr	3 yr	3 yr	3 yr	3 yr

<sup>1</sup> Effective: Aug. 2010

## 11 Contact address

### **PALFINGER Liftgates, LLC.**

15939 Piuma Ave  
Cerritos, CA 90703

Phone: (562)-924-8218  
Fax: (562)-924-8318  
E-mail (parts order): [customerservice@PALFINGER.com](mailto:customerservice@PALFINGER.com)  
E-mail (technical support): [technicalservice@PALFINGER.com](mailto:technicalservice@PALFINGER.com)

### **PALFINGER Liftgates, LLC.**

572 Whitehead Road  
Trenton, NJ 08619

Phone: (609)-587-4200  
Fax: (609)-587-4201  
E-mail (parts order): [customerservice@PALFINGER.com](mailto:customerservice@PALFINGER.com)  
E-mail (technical support): [technicalservice@PALFINGER.com](mailto:technicalservice@PALFINGER.com)