

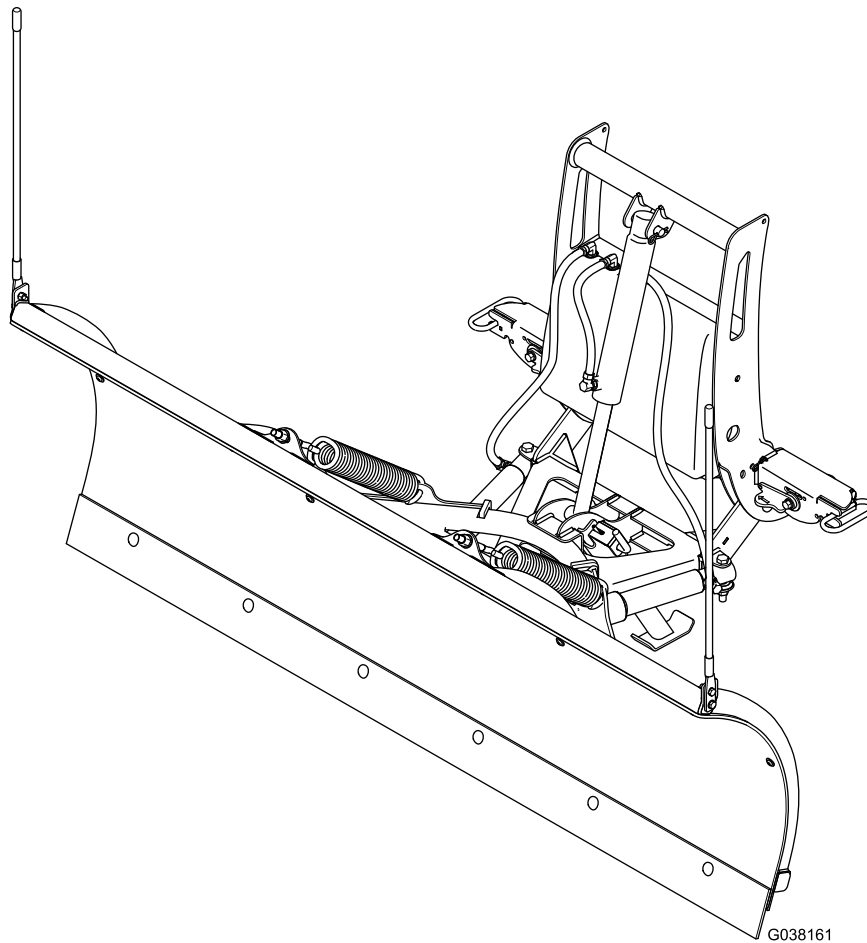

P.O. Box 787
Iron Mountain, MI 49801
United States

Owner's Manual

RT3 UTV Straight-Blade Plow



This product complies with all relevant European directives; for details, please see the separate product specific Declaration of Conformity (DOC) sheet.

▲ WARNING

CALIFORNIA Proposition 65 Warning

This product contains a chemical or chemicals known to the State of California to cause cancer, birth defects, or reproductive harm.

Introduction

Note: This manual is used for the assembly of all BOSS UTV straight-blade plows. Illustrations may vary.

Contents

Safety	2
Preparation.....	2
Operation.....	2
Safety and Instructional Decals	3
Setup	5
Installing the Push Frame and Coupler	5
Installing the Hydraulic Hoses.....	6
Installing the Blade Guides and Filling the Hydraulic Reservoir	6
Installing the Wire Harness.....	7
Mounting the Plow Controller.....	9
Mounting the Snowplow	9
Product Overview	10
Controls	10
Operation	11
Mounting the Snowplow	11
Removing the Snowplow.....	12
Checking the Hydraulic Fluid Level.....	13
Adding Hydraulic Fluid.....	13
Maintenance	14
Draining the Hydraulic Fluid.....	14
Checking the Hydraulic Lines and Hoses.....	14
Storage	15
Storing the Plow.....	15
Removing the Plow from Storage.....	15
Troubleshooting	16
Schematics	19

Safety

Improper use or maintenance by the operator or owner can result in injury. To reduce the potential for injury, comply with these safety instructions and always pay attention to the safety-alert symbol ▲, which means: *Caution, Warning, or Danger*—personal safety instruction. Failure to comply with the instruction may result in personal injury or death.

Preparation

- Read the *Owner's Manual* before operating or servicing the plow.
- Always follow the vehicle manufacturer's recommendations relating to snowplow installation. For recommended vehicle models, refer to the *BOSS Snowplow Application Chart and Selection Guide*.
- Follow all operator safety instructions and age restrictions found in your UTV *Owner's Manual*.
- Ensure that only trained personnel install and perform maintenance on the equipment.
- Keep your hands, feet, and clothing away from moving parts and mounting points.
- Ensure the plow is properly attached to the vehicle before moving it.
- Always wear appropriate personal protective equipment when loading, unloading, and servicing the plow. Wear substantial, slip-resistant footwear, cold-weather clothing, safety glasses, and dust protection.

Operation

- Use a 500 kg (1/2 ton) minimum lifting device to move heavy plow components.
- When transporting the vehicle, position the plow so as not to block your vision.
- **Do not** exceed 8 km/h (5 mph) when changing the blade position.
- **Do not** exceed 38 km/h (24 mph) when transporting the plow.
- **Do not** exceed 22 km/h (14 mph) when plowing.
- Always lower the blade when the vehicle is not in use.
- **Never** put any part of your body between the plow and the vehicle.
- **Do not** climb or ride on the plow.
- Do not operate on steep inclines.
- Do not operate the machine while ill, tired, or under the influence of alcohol or drugs.
- Always wear your seat belt and other protective equipment while operating the plow.
- Ensure that you do not exceed the front gross-axle-weight rating (FGAWR), rear gross-axle-weight rating (RGAWR), and the gross-vehicle-weight rating (GAWR) at any time.

This may require weighing the vehicle and adding ballast as necessary. It may also limit the payload capacity of the vehicle.

- The sport duty UTV straight-blade plow is for personal, non-commercial use only. Using the plow in a commercial setting voids the plow warranty.

Safety and Instructional Decals



Safety decals and instructions are easily visible to the operator and are located near any area of potential danger. Replace any decal that is damaged or missing.

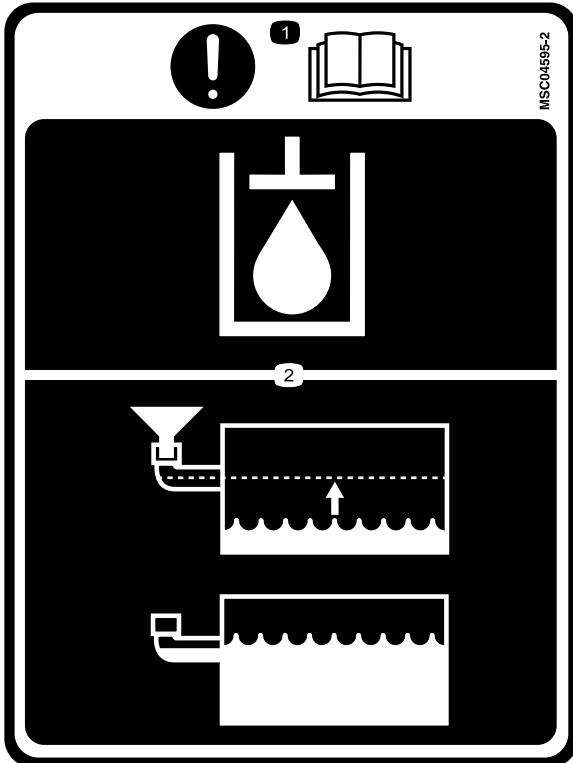

MSC04595

1. Important—read the *Owner's Manual*.
2. Fill the hydraulic fluid to the bottom of the fill elbow.

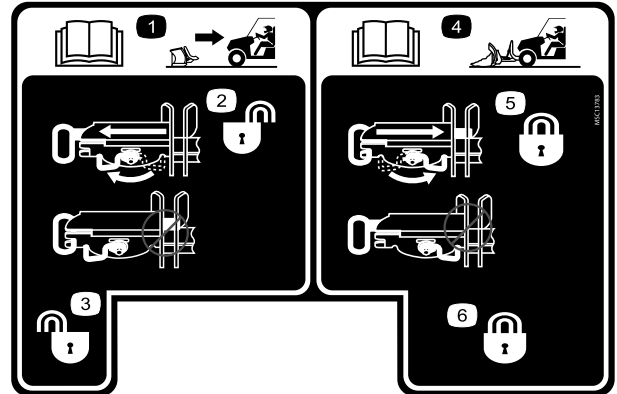

MSC13783

1. Read the *Owner's Manual* for information on removing the plow.
2. Coupler spring pin—unlock
3. Coupler spring pin—unlock
4. Read the *Owner's Manual* for information on attaching the plow.
5. Coupler spring pin—lock
6. Coupler spring pin—lock

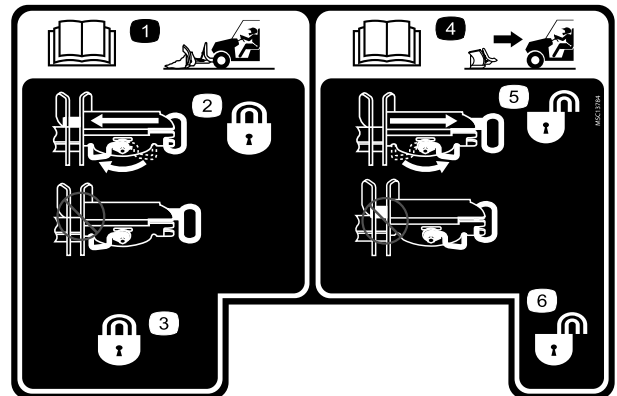

MSC13784

1. Read the *Owner's Manual* for information on attaching the plow.
2. Coupler spring pin—lock
3. Coupler spring pin—lock
4. Read the *Owner's Manual* for information on removing the plow.
5. Coupler spring pin—unlock
6. Coupler spring pin—unlock



MSC12453

1. Warning—read the *Owner's Manual*.
2. Warning—all operators should be trained before operating the machine.
3. Warning—wear your seatbelt and helmet while operating the plow.
4. Warning—coupler spring pins must be locked before plowing.
5. Warning—coupler spring pins must be unlocked to remove the plow.
6. Warning—do not block driver visibility with the plow.
7. Crushing hazard—do not stand between the plow and vehicle during maintenance.
8. Warning—do not exceed 40 km/h (25 mph) when transporting the plow.
9. Warning—do not exceed 23 km/h (14 mph) when plowing; keep the vehicle in low when plowing.
10. Warning—lower the plow when the vehicle is not in use.

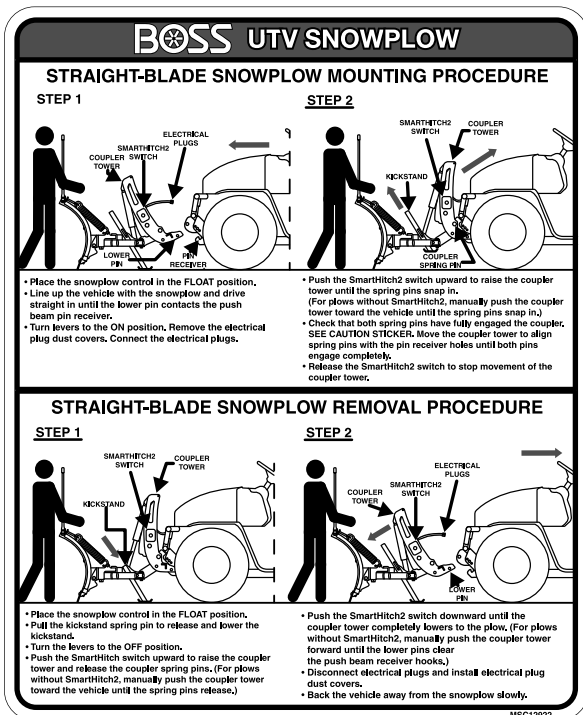

MSC12922

Setup

Determine the left and right sides of the machine from the normal operating position.

Installing the Push Frame and Coupler

1. Attach the front of the push-frame assembly to the plow blade using 2 bolts (5/8 inch) and self-locking nuts (Figure 1). Torque the bolts to 153 N·m (113 ft-lb).

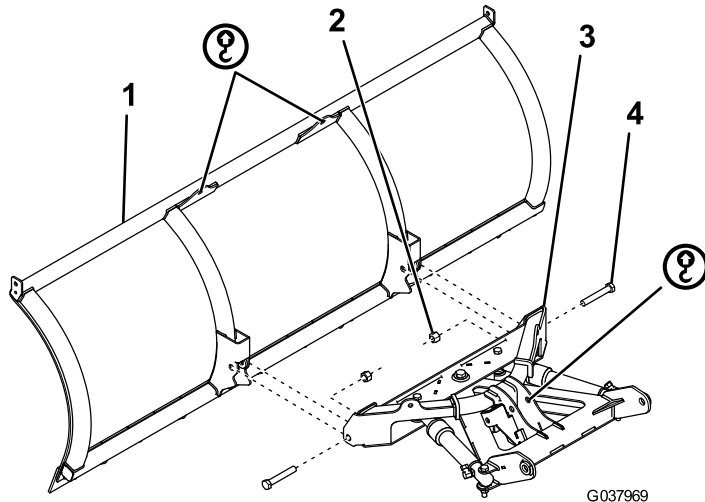

Figure 1

- | | |
|---------------------|------------------------|
| 1. Plow blade | 3. Push frame assembly |
| 2. Self-locking nut | 4. Bolt (5/8 inch) |

2. Pull the kickstand-spring pin to release and lower the kickstand (Figure 2).

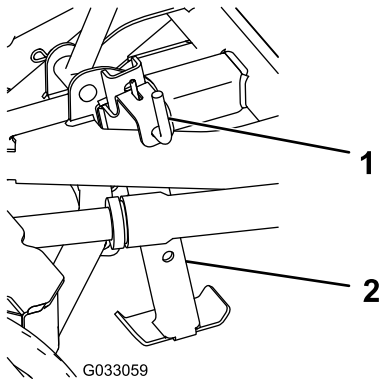

Figure 2

- | | |
|-------------------------|--------------|
| 1. Kickstand spring-pin | 2. Kickstand |
|-------------------------|--------------|

3. Hook the 2 trip springs through the holes on the push-frame assembly (Figure 3).

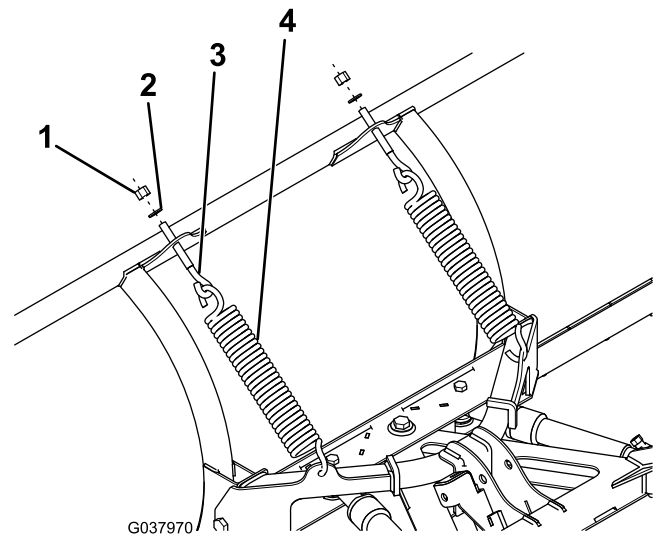

Figure 3

- | | |
|---------------------|----------------|
| 1. Self-locking nut | 3. Eye bolt |
| 2. Washer | 4. Trip spring |

4. Hook the other ends of the trip springs to 2 eyebolts (Figure 3).
5. Insert the threaded end of the eyebolts through the holes on the plow blade and secure them using 2 washers (1/2 inch) and 2 self-locking nuts (Figure 3).
6. Tighten the self-locking nuts until there is a gap of 0.8 mm (1/32 inch) between the trip spring coils.
7. Align the pivot holes of the coupler tower with the pivot holes on the push-frame assembly, and secure them with 2 pivot pins, 2 flat washers (3/4 inch), and 2 cotter pins (Figure 4).

Note: Make sure to spread the ends of the cotter pins.

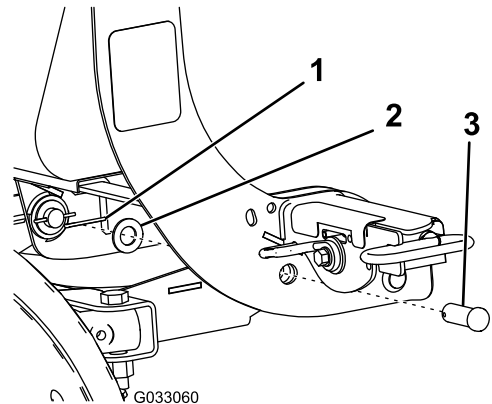

Figure 4

- | | |
|----------------|--------------|
| 1. Cotter pin | 3. Pivot pin |
| 2. Flat washer | |

8. Secure the rod end of the lift cylinder to the push-frame assembly using a clevis pin and hairpin cotter (Figure 5).

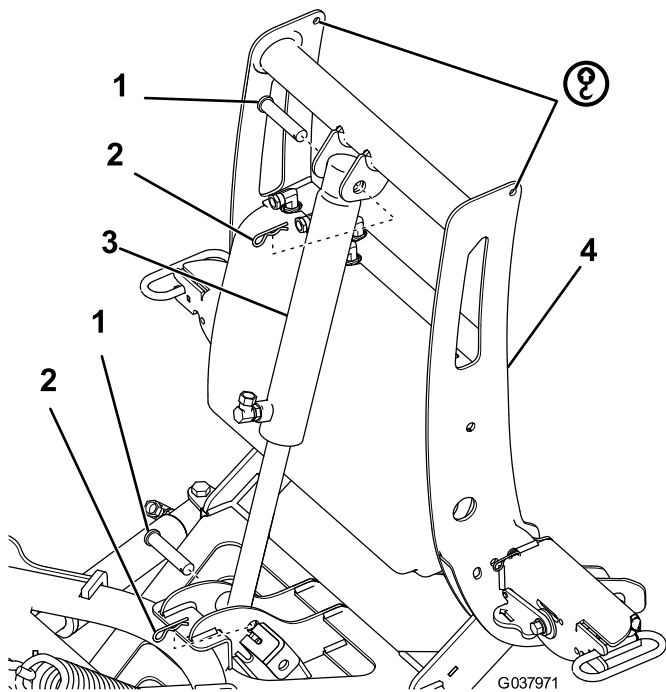

Figure 5

- | | |
|-------------------|------------------|
| 1. Clevis pin | 3. Lift cylinder |
| 2. Hairpin cotter | 4. Coupler tower |

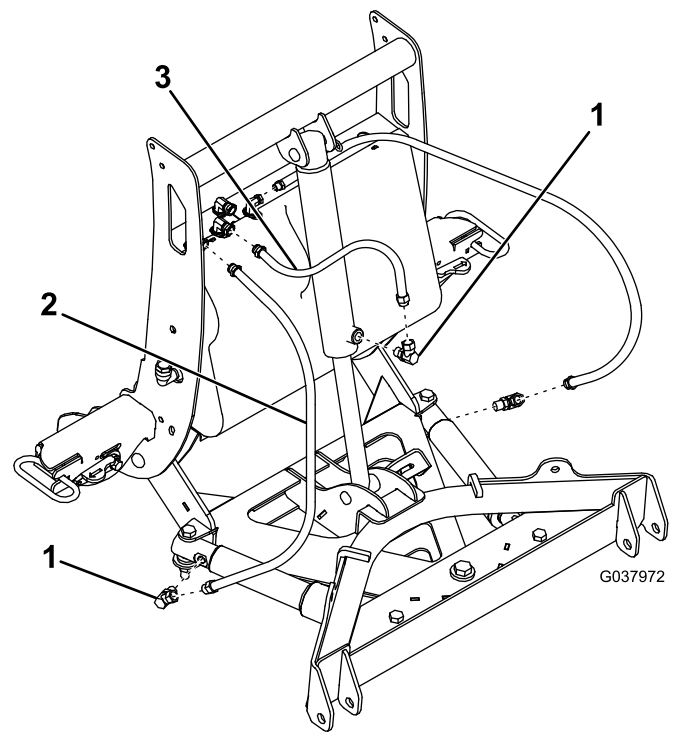

Figure 6

- | | |
|-------------------------|-----------------------------|
| 1. 90° fitting | 3. 39 cm (15-1/2 inch) hose |
| 2. 76 cm (30 inch) hose | |

9. Secure the free end of the lift cylinder to the coupler tower using a clevis pin and hairpin cotter (Figure 5).

Installing the Hydraulic Hoses

1. Remove the plug from the lower port on the lift cylinder.
2. Using thread compound, install a 90° fitting to the lower port on the lift cylinder (Figure 6).

3. Install the 39 cm (15-1/2 inch) hydraulic hose to the middle fitting on the hydraulic shelf and the previously installed 90° fitting (Figure 6). Turn the fitting until it is finger tight, then turn it 2 to 3 more times.

Important: Do not overtighten.

4. Using thread compound, install a 90° fitting to the right angle cylinder located on the push-frame assembly (Figure 6).

Note: The fitting should be installed at a 45° angle pointing forward.

5. Install the 76 cm (30 inch) hydraulic hose to the right fitting on the hydraulic shelf and the previously installed 90° fitting (Figure 6). Turn the fitting until it is finger tight, then turn it 2 to 3 more times.

Important: Do not overtighten.

6. Repeat steps 4 and 5 on the left side.
7. Remove the plug on the upper fitting on the lift cylinder, and install the breather vent.

Installing the Blade Guides and Filling the Hydraulic Reservoir

1. Attach the blade guides to the plow blade using 2 bolts (5/16 inch), 2 self-tapping bolts, and 2 self-locking nuts (Figure 7).

Installing the Wire Harness

⚠ DANGER

Vehicle engines contain moving parts and can become extremely hot, capable of causing severe burns and serious bodily harm.

Shut off the engine and allow it sufficient time to cool down before installing this kit.

⚠ DANGER

Vehicle batteries can cause dangerous electrical shocks that could lead to severe burns or death.

Disconnect your battery before installing this kit.

Note: Apply dielectric grease to all electrical connections.

Note: Some vehicles require a battery cable extension kit. Contact your Authorized BOSS Dealer for more information.

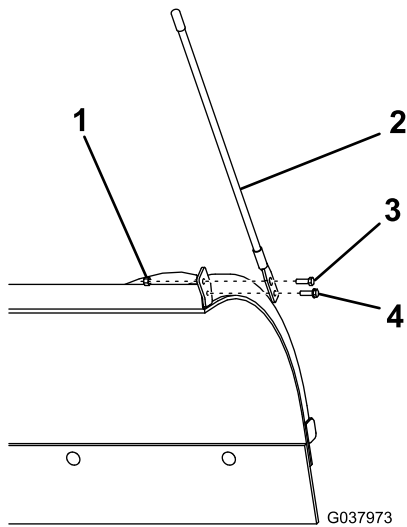

Figure 7

- | | |
|---------------------|----------------------|
| 1. Self-locking nut | 3. Bolt (5/16 inch) |
| 2. Blade guide | 4. Self-tapping bolt |

2. Ensure that the lift cylinder is completely collapsed.
3. Remove the fill cap from the hydraulic reservoir elbow (Figure 8).

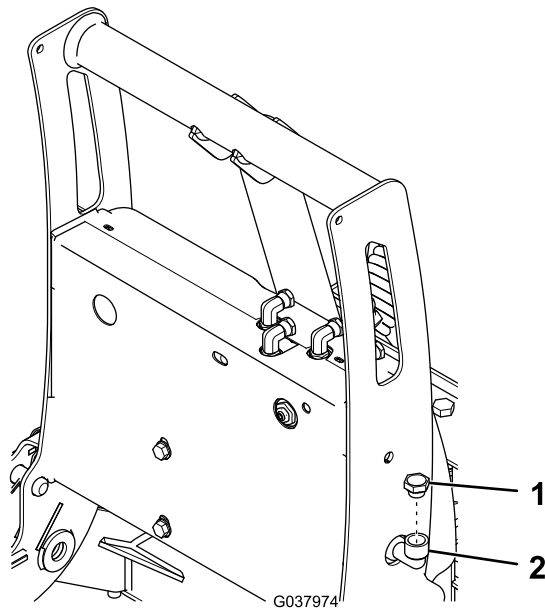

Figure 8

- | | |
|-------------|------------------------------|
| 1. Fill cap | 2. Hydraulic reservoir elbow |
|-------------|------------------------------|

4. Slowly fill the reservoir with BOSS high-performance hydraulic-fluid until it accepts no more.

Note: The reservoir holds approximately 1.9 L (2 US qt) of hydraulic fluid.

5. Install the previously removed fill cap.

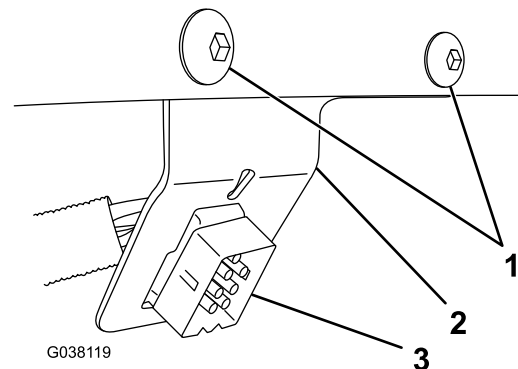

Figure 9

- | | |
|-----------------------|------------------------------|
| 1. Self-tapping bolts | 3. Plow controller connector |
| 2. Dash bracket | |

3. Mount the plow controller connector to the dash bracket, and secure the bracket to the left of the steering wheel using 2 self-tapping bolts (Figure 9).
4. Plug the plow controller into the plow controller connector.
5. Mount the plow controller; refer to [Mounting the Plow Controller](#) (page 9).
6. Connect the black/red wire to a keyed 12 V+ ignition source.

Note: Connecting the wire to a source that is not keyed can cause the battery to drain.

7. Connect the white/black wire from the wire harness to the small post on the pump solenoid (Figure 10).

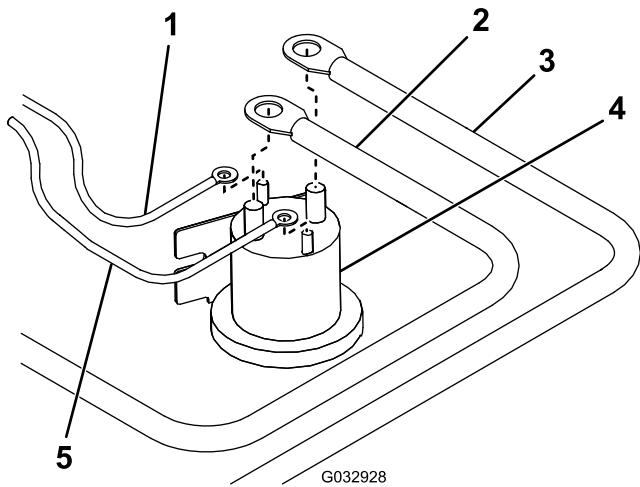

Figure 10

- | | |
|---------------------------|------------------|
| 1. White/black wire | 4. Pump solenoid |
| 2. Battery cable | 5. Brown wire |
| 3. Red power/ground cable | |

-
8. Connect the brown wire from the wire harness to the other small post on the pump solenoid (Figure 10).
- Note:** The wires may go on either small post, but should not share a post.
9. Mount the pump solenoid under the hood of the vehicle, ensuring that it stays in an upright position and does not contact the body, hood, or other conductive material on the vehicle.
10. Connect the red power/ground cable to the large post on the pump solenoid (Figure 10).
11. Connect the battery cable to the other large post on the pump solenoid (Figure 10).

Note: The wires may go on either large post, but should not share a post.

12. Mount the UTV-side, wire-harness plow connector to the left side of the top tube of the bumper using the control-harness mounting-bracket and 2 self-tapping bolts (Figure 11).

Note: You will have to drill 2 holes in the bumper tube to mount the bracket.

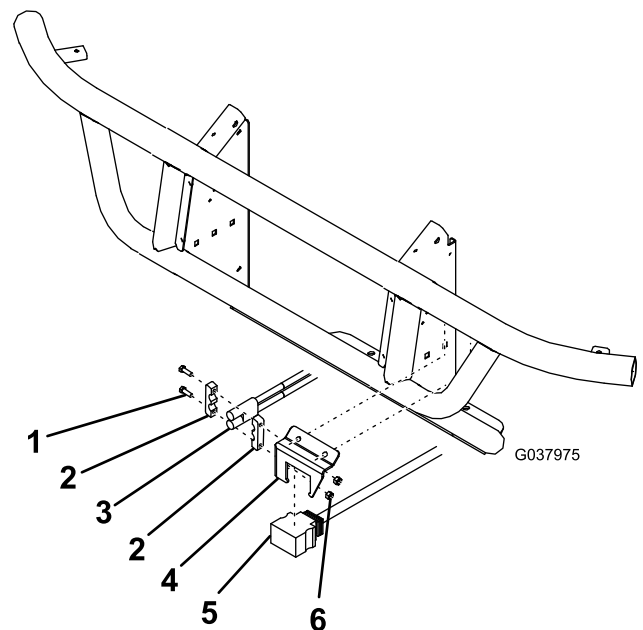

Figure 11

- | | |
|---------------------------|-------------------------------------|
| 1. Bolt | 4. Control harness mounting bracket |
| 2. Power/Ground connector | 5. Plow connector |
| 3. Power/ground connector | 6. Nut |

-
13. Mount the black and red power/ground connector to the control harness mounting bracket (Figure 11).
14. Mount the relay pack under the hood using 1 sheet-metal screw (Figure 12).

Note: Ensure that the relay pack is mounted in the upright position.

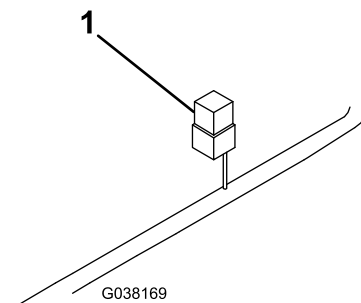

Figure 12

1. Relay pack

-
15. Connect the black power/ground cable to the negative (-) battery terminal (Figure 13).

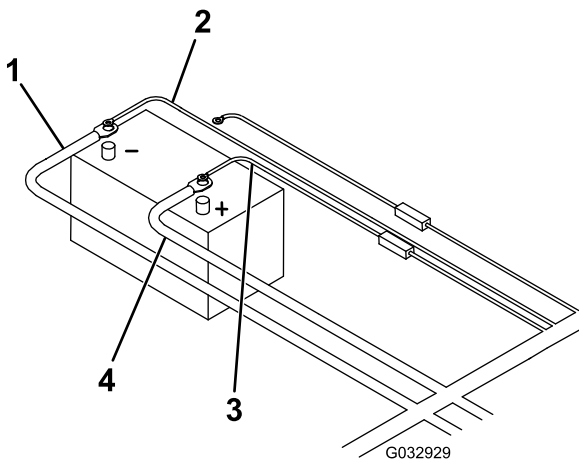

Figure 13

- | | |
|-----------------------------|-------------------|
| 1. Black power/ground cable | 3. Red fused wire |
| 2. Brown wire | 4. Battery cable |

16. Connect the brown wire to the negative (-) battery terminal (Figure 13).
17. Connect the free end of the battery cable to the positive (+) battery terminal (Figure 13).
18. Connect the red, fused wire to the positive (+) battery terminal (Figure 13).
19. Secure all wiring in a position that avoids hot or moving parts using cable ties.

Mounting the Plow Controller

Mounting the SmartTouch2™ Controller

Note: Mount the controller in the cab in a dry area where it does not interfere with vehicle operation or visibility.

Important: Do not install the swivel mount when temperatures are below 16°C (60°F).

▲ DANGER

The controller could cause serious injury if contacted during a crash.

Mount the controller in a location that vehicle occupants will not contact during a crash.

1. Determine the mounting location for the controller.
2. Clean the location with the provided alcohol wipe and dry it with a cloth or paper towel.
3. Clean the back of the swivel mount (Figure 14) with the alcohol wipe and then dry it.

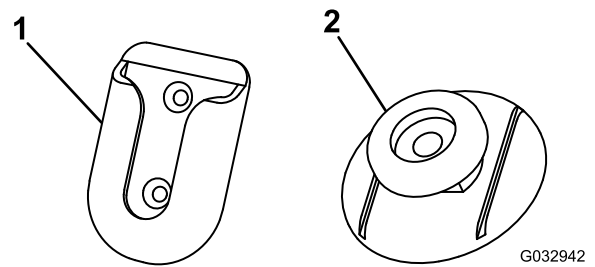

Figure 14

- | | |
|-----------------|-----------------|
| 1. Swivel mount | 2. Mounting tab |
|-----------------|-----------------|

4. Remove the backing from 1 side of the adhesive and apply it to the back of the swivel mount.
5. Remove the remaining backing from the swivel-mount adhesive and press the swivel mount to the clean area of the dashboard for 30 seconds.

Important: Once the mount is placed, you cannot remove it without destroying the adhesive.

6. Clean the back of the controller with the alcohol wipe and then dry it.
7. Remove the backing from 1 side of the adhesive and apply it to the back of the mounting tab (Figure 14).
8. Remove the remaining backing from the controller adhesive and press the mounting tab to the controller for 30 seconds.
9. Let the swivel mount rest unused for 72 hours before sliding the controller into the mounting bracket.

Important: Mounting the controller immediately may cause the adhesive to fail.

10. Continue the wire harness installation from step 6 of [Installing the Wire Harness \(page 7\)](#).

Mounting the Snowplow

Refer to [Mounting the Snowplow \(page 9\)](#) to mount the plow.

Product Overview

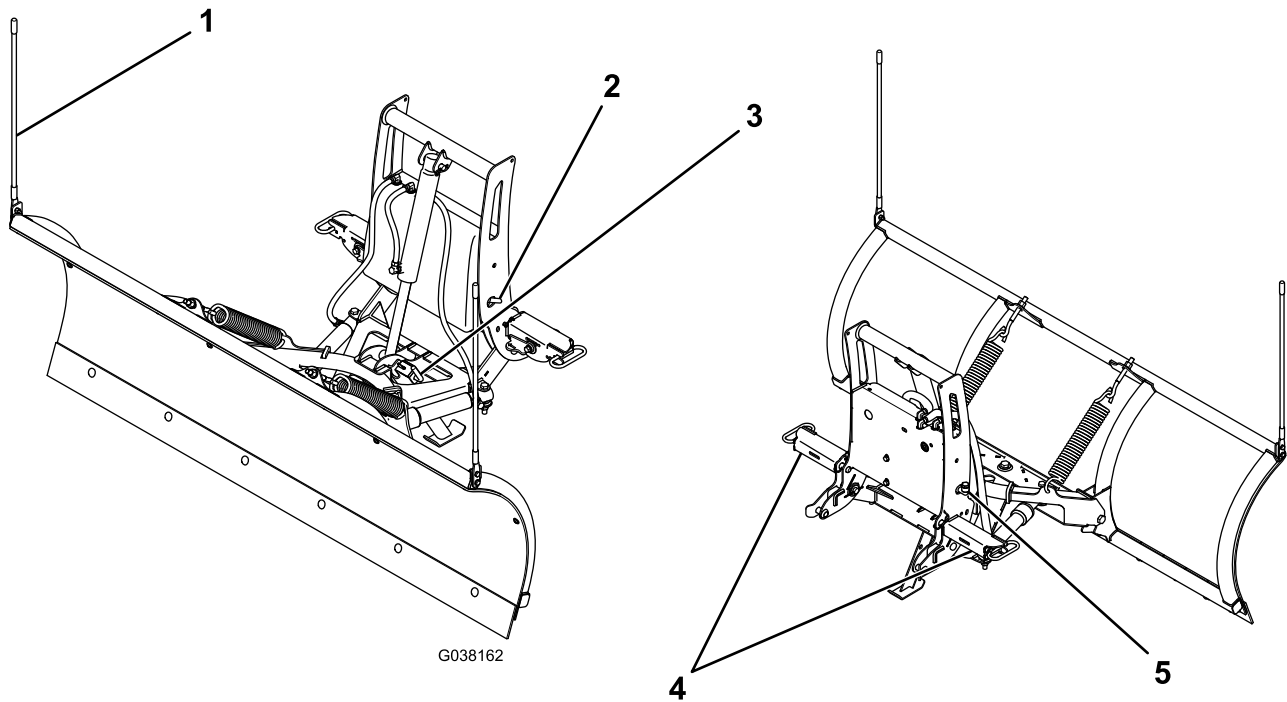

Figure 15

- 1. Blade guide
- 2. SmartHitch2 switch
- 3. Kickstand spring pin

- 4. Couplers
- 5. Hydraulic fluid fill elbow

Controls

Become familiar with all the controls before you operate the plow.

SmartHitch2 Switch

The SmartHitch2 switch controls the movement of the coupler tower to facilitate plow attachment and removal. Press the switch up to raise the tower and down to lower the tower.

Couplers

The couplers secure the plow to the vehicle push beam. Turn the levers toward the coupler tower to turn on the spring pins. Turn the levers away from the coupler tower to turn off the spring pins.

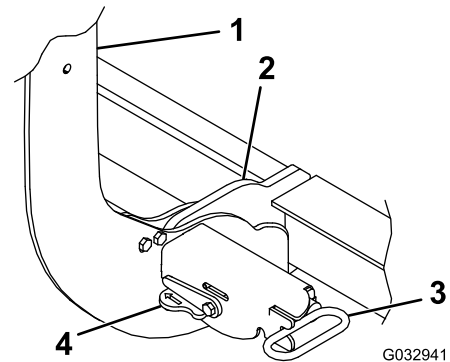

Figure 16

- 1. Coupler tower
- 2. Pin receiver
- 3. Coupler spring-pin
- 4. Coupler lever

SmartTouch2 Controller

The SmartTouch2 controller operates the movement of the snowplow.

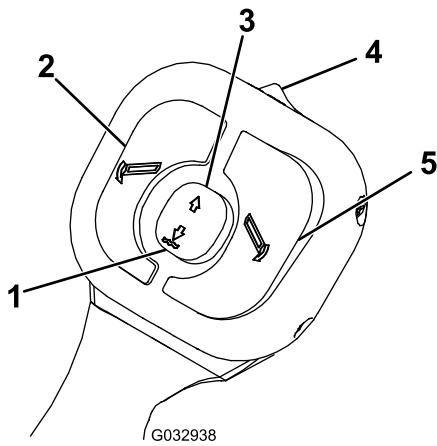

Figure 17

- | | |
|-----------------------|------------------|
| 1. Lower/Float button | 4. On/Off switch |
| 2. Left button | 5. Right button |
| 3. Raise button | |

- On/Off switch—turns the plow controller on and off. A green light illuminates when the controller is on.

Note: Turn off the controller when not in use to prevent accidental activation of the plow.

- Raise button—raises the plow blade. Pressing the button quickly twice automatically raises the blade.
- Lower/Float button—lowers the plow blade and activates the Float feature. Pressing the button quickly twice automatically lowers the blade and activates the Float feature, allowing the plow blade to follow the contour of the ground. A red light illuminates when the Float feature is active.
- Left button—angles the plow blade to the left
- Right button—angles the plow blade to the right
- Sleep mode—If you do not use the controller for 20 minutes, it enters sleep mode and the controller lights flash green and red. Turn the controller off to deactivate the sleep mode.

Operation

Determine the left and right sides of the machine from the normal operating position.

Mounting the Snowplow

Note: The vehicle must be running before starting this procedure.

1. Activate the FLOAT feature on your plow controller.
2. Line up the vehicle with the snowplow and drive forward until the lower pin contacts the push-beam pin receiver (Figure 18).

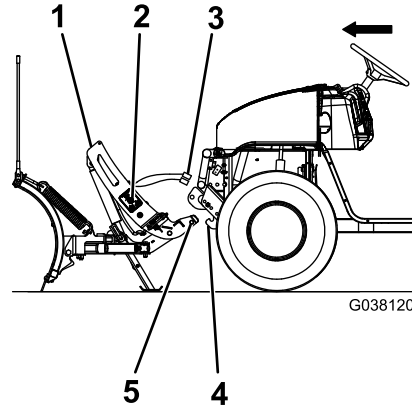

Figure 18

- | | |
|-----------------------|-----------------|
| 1. Coupler tower | 4. Pin receiver |
| 2. SmartHitch2 switch | 5. Lower pin |
| 3. Plow wire harness | |

3. Turn the levers on the couplers to the ON position (Figure 19).

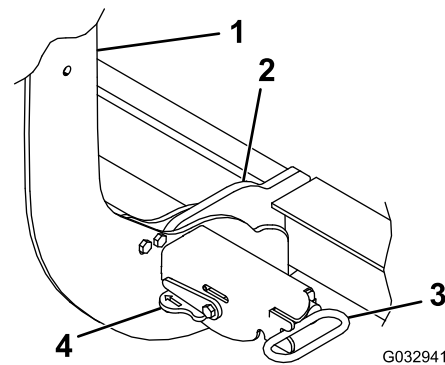

Figure 19

- | | |
|------------------|-----------------------|
| 1. Coupler tower | 3. Coupler spring pin |
| 2. Pin receiver | 4. Coupler lever |

4. Remove the electrical-plug dust-covers and connect the plow wire harness to the vehicle wire harness (Figure 18).
5. Push the SmartHitch2 switch on the side of the coupler tower upward and raise the tower until the coupler spring pins snap in (Figure 20).

Note: For plows without the SmartHitch2, manually push the coupler tower toward the vehicle until the spring pins snap in.

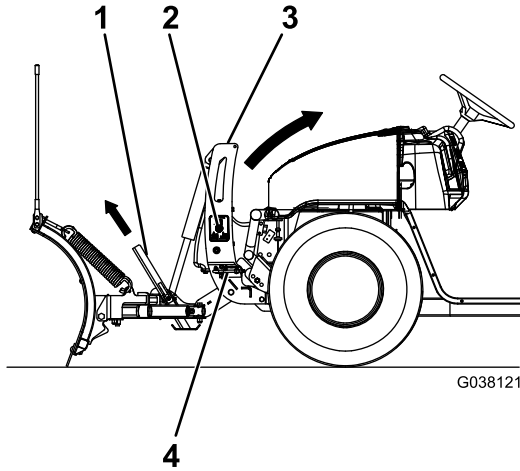

Figure 20

- | | |
|-----------------------|-----------------------|
| 1. Kickstand | 3. Coupler tower |
| 2. SmartHitch2 switch | 4. Coupler spring pin |

6. Ensure that both coupler spring pins have fully engaged the coupler (Figure 19).

Note: Move the coupler tower until the spring pins engage completely.

7. Pull the kickstand spring-pin outward and raise the kickstand, then release the spring pin to secure it (Figure 20).

Removing the Snowplow

Note: The vehicle must be running before starting this procedure.

1. Switch the headlight toggle switch to the TRUCK position.
2. Activate the FLOAT feature on your plow controller.
3. Pull the kickstand spring pin outward and lower the kickstand, then release the spring pin to secure it (Figure 21).

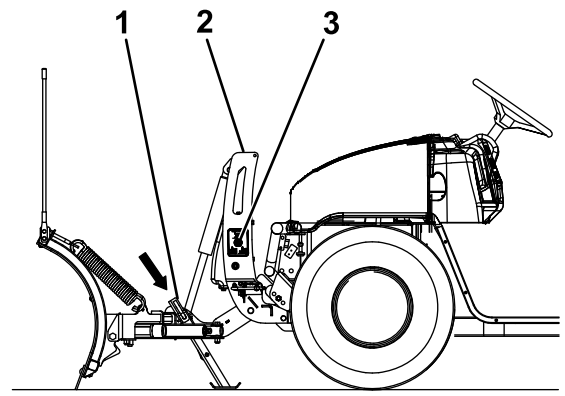

Figure 21

- | | |
|------------------|-----------------------|
| 1. Kickstand | 3. SmartHitch2 switch |
| 2. Coupler tower | |

4. Turn the levers on the couplers to the OFF position (Figure 22).

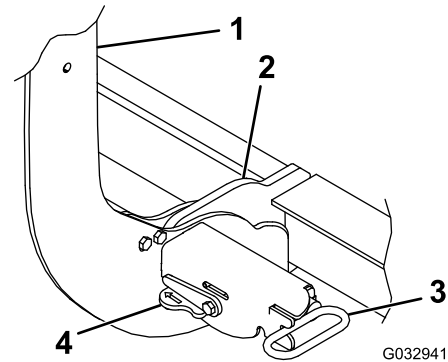

Figure 22

- | | |
|------------------|-----------------------|
| 1. Coupler tower | 3. Coupler spring pin |
| 2. Pin receiver | 4. Coupler lever |

5. Push the SmartHitch2 switch on the side of the coupler tower downward and lower the tower completely (Figure 23).

Note: For plows without the SmartHitch2, manually push the coupler tower away from the vehicle until the spring pins release.

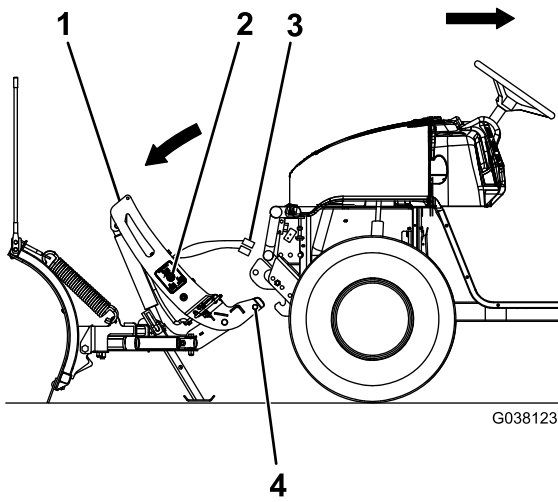

Figure 23

- | | |
|-----------------------|----------------------|
| 1. Coupler tower | 3. Plow wire harness |
| 2. SmartHitch2 switch | 4. Lower pin |

- Disconnect the plow wire harness from the vehicle wire harness and secure the electrical-plug dust-covers (Figure 23).
- Slowly back the vehicle away from the snowplow.

Checking the Hydraulic Fluid Level

- With the plow mounted to the vehicle, lower the plow to the ground and ensure that it is in the straight position.
- Clean the area around the fill cap (Figure 24).

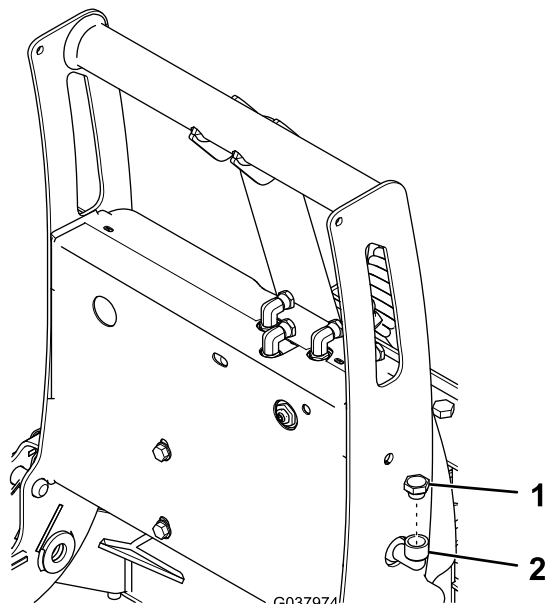

Figure 24

- | | |
|-------------|---------------|
| 1. Fill cap | 2. Fill elbow |
|-------------|---------------|

- Remove the fill cap from the hydraulic reservoir (Figure 24).
- Ensure that the fluid comes up to the bottom of the fill elbow. If it does not, add more hydraulic fluid; refer to Adding Hydraulic Fluid (page 13).
- Install the previously removed fill cap.

Adding Hydraulic Fluid

- Ensure that the lift cylinder is completely collapsed.

Important: Do not manually pull the tower down. This can cause an air pocket to form in the hydraulic system and fluid to spill out of the internal filler cap.

- Clean the area around the fill cap (Figure 24).
- Remove the fill cap from the hydraulic reservoir (Figure 25).
- Slowly fill the reservoir with BOSS high-performance hydraulic fluid to the bottom of the fill elbow (Figure 25).

Note: The reservoir holds approximately 1.9 L (2 US qt) of hydraulic fluid.

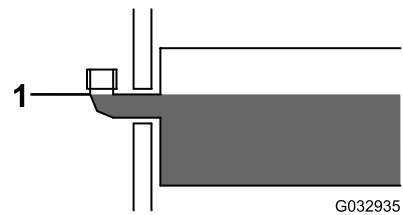

Figure 25

- Install the previously removed fill cap.
- Start the vehicle and operate the plow in its full range of movement.
- Stop the vehicle, check the hydraulic-fluid level, and replenish the fluid if necessary; refer to Checking the Hydraulic Fluid Level (page 13).

Maintenance

Determine the left and right sides of the machine from the normal operating position.

Draining the Hydraulic Fluid

Before each use or daily

Yearly

If the oil becomes contaminated, contact your authorized BOSS dealer to have the system flushed.

1. Park the vehicle on a level surface, lower the plow, and fully collapse the hydraulic lift-cylinder. Turn off the vehicle and remove the keys.
2. Remove the hairpin cotter and clevis pin from the top of the lift cylinder and lean it forward (Figure 26).

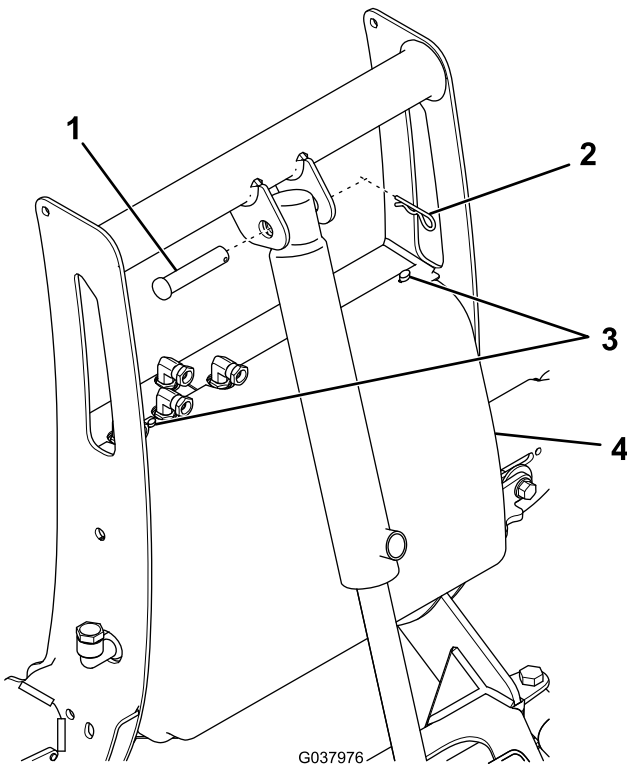

Figure 26

- | | |
|-------------------|------------------------|
| 1. Clevis pin | 3. Thumb screws |
| 2. Hairpin cotter | 4. Coupler-tower cover |

3. Remove the 2 thumb screws securing the coupler-tower cover to the coupler tower (Figure 26).
4. Remove the coupler-tower cover, pulling it toward the passenger side of the plow.

Note: You may need to tug the cover back and forth several times to get it free.

5. Clean the area around the drain plug (Figure 27).

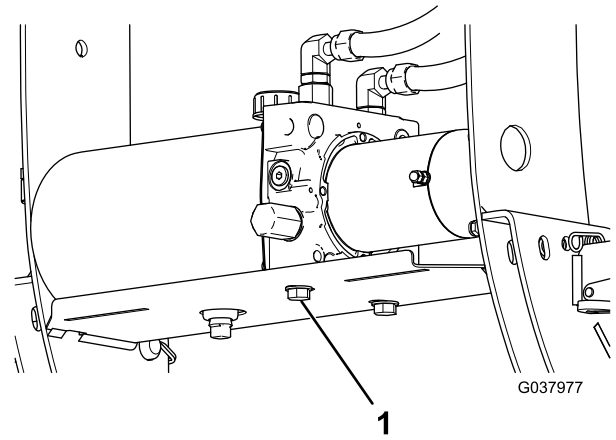

Figure 27

1. Drain plug
6. Place a drain pan under the plug and remove the plug.
7. Clean the drain plug.
8. Allow the fluid to fully drain, then replace the plug. Torque the plug to 17 to 28 N·m (150 to 250 in-lb).
9. Attach the previously removed coupler-tower cover.
10. Attach the previously removed lift cylinder.

Checking the Hydraulic Lines and Hoses

Service Interval: Before each use or daily

⚠ WARNING

Hydraulic fluid escaping under pressure can penetrate the skin and cause injury.

- Ensure that all hydraulic fluid hoses and lines are in good condition and all hydraulic connections and fittings are tight before applying pressure to the hydraulic system.
- Keep your body and hands away from pin-hole leaks or nozzles that eject high-pressure hydraulic fluid.
- Use cardboard or paper to find hydraulic leaks.
- Safely relieve all pressure in the hydraulic system before performing any work on the hydraulic system.
- Get immediate medical help if fluid is injected into skin.

Check the hydraulic lines and hoses daily for leaks, kinked lines, loose mounting supports, wear, loose fittings, weather deterioration, and chemical deterioration. Make all necessary repairs before operating.

Storage

Storing the Plow

1. Grease any exposed chrome or nitro bar on the plow-angle lift cylinders.
2. Drive the snowplow to your storage location and remove the plow; refer to [Removing the Snowplow \(page 12\)](#).
3. Power the coupler tower forward until the lift cylinder is completely compressed.
4. Apply dielectric grease to all of the wire-harness connectors and install the dust caps.
5. Lightly sand and use touch-up paint on painted areas that are scratched, chipped, or rusted.
6. Loosen the trip-return springs.
7. Grease the coupler spring pins.

Removing the Plow from Storage

1. Check the plow for cracked welds.
2. Check the torque of all fasteners, pins, retainers, nuts, and bolts; tighten as necessary.
3. Check the hydraulic lines and hoses for cracks or leaks.
4. Replace the hydraulic fluid; refer to [Draining the Hydraulic Fluid \(page 14\)](#).
5. Check the cutting edge for wear.
6. Tighten the trip-return springs.
7. Lightly sand and use touch-up paint on painted areas that are scratched, chipped, or rusted.
8. Grease the coupler spring pins.
9. Apply dielectric grease to all of the wire harness connectors.
10. Attach the plow to the vehicle; refer to [Mounting the Snowplow \(page 11\)](#).
11. Move the plow through its range of motion to check the hydraulic cylinder rods.

Troubleshooting

Problem	Possible Cause	Corrective Action
The pump motor does not run.	<ol style="list-style-type: none"> 1. Check that the power/ground cables and control cables are connected properly. 2. Check for voltage at the pump motor while the ignition switch is on and the RAISE button is pressed on the controller. 3. Check for power to the solenoid by testing for voltage between both large terminals and ground. 4. Check for voltage between the other large terminal of the solenoid and ground while jumping power to the small terminal with the white/black wire. 5. Test the power to the controller by checking the voltage between the black wire and ground at the white 9-pin connector. 	<ol style="list-style-type: none"> 1. Connect the cables if they are not connected. 2. If voltage is present, the pump motor has failed or the pump has seized. Motor brushes may be replaced, otherwise replace the pump/motor assembly. 3. If voltage is not present between one large terminal and ground, the cable between the battery and the solenoid is disconnected or broken. 4. If no voltage is present, the solenoid has failed and must be replaced. If voltage is present, the wire from the small terminal of the solenoid to ground may be disconnected or broken. 5. If no voltage is present, power from the relay has become disconnected. If voltage is present, check the wiring and controller switches.
The pump continues to run while the switch is in neutral.	<ol style="list-style-type: none"> 1. Disconnect the controller and turn the ignition on. 2. Disconnect the controller and turn the ignition on. 	<ol style="list-style-type: none"> 1. If the pump continues to run, the solenoid has failed in the closed position. Quickly remove power to the pump by disconnecting the power/ground cables to the plow. Replace the solenoid. 2. If the pump stops running, check the wiring of the controller for a short between the black and white/black wire in the controller, or a failed switch.
The plow does not lower.	<ol style="list-style-type: none"> 1. Check that the power/ground cables and control cables are connected properly. 2. Check the flow-control valve. 3. Check the wiring on the valve block for proper connections. 4. Check for voltage between the solenoid valve terminal and ground while the ignition switch is on and the controller is in the FLOAT position. 5. Test the power to the control box by checking the voltage between the black wire and ground at the white 9-pin connector. 	<ol style="list-style-type: none"> 1. Connect the cables if they are not connected. 2. If the flow-control valve is completely closed, place the controller in neutral, then open the flow-control valve. 3. Refer to the wiring diagram included with your <i>Owner's Manual</i>. 4. If voltage is present, the solenoid valve or valve coil has failed. Replace the valve or valve coil. 5. If no voltage is present, power from the relays has become disconnected. If voltage is present, check the wiring and switch off the controller.
The plow lowers too fast.	<ol style="list-style-type: none"> 1. Check the flow-control valve. 	<ol style="list-style-type: none"> 1. Close the flow-control valve to the desired drop speed.

Problem	Possible Cause	Corrective Action
The plow does not raise or raises slowly.	<ol style="list-style-type: none"> 1. Check the hydraulic-fluid level. 2. Check that the power/ground cables and the control cable are connected properly. 3. Check the wiring on the valve block for proper connections. 4. Load a test battery. 5. Check the pressure at the pressure port of the pump. 6. Check the RAISE control solenoid valve. 	<ol style="list-style-type: none"> 1. The hydraulic-fluid level should be within 2 cm (3/4 inch) of the top of the reservoir when lowered and in the V position. 2. Connect the cables if they are not connected. 3. Refer to the manifold wiring diagram included with your <i>Owner's Manual</i>. 4. Replace the battery if it is weak or defective. 5. If the pressure is less than 2,500 psi (at the end of the lift), the motor brushes may be defective, the pump pressure relief valve may be contaminated, damaged, or set to less than 2,500 psi, or the pump may be worn. 6. If the RAISE solenoid valve is not opening completely, replace it.
The plow angles while plowing.	<ol style="list-style-type: none"> 1. Check the ANGLE control solenoid valve. 2. Check that the pressure relief valve is not contaminated. 3. Check that the pressure relief valve is set correctly. 	<ol style="list-style-type: none"> 1. If the ANGLE control solenoid valve is contaminated, clean or replace it. 2. If the pressure relief valve is contaminated, clean or replace it. 3. If the pressure is set too low, contact your authorized BOSS dealer.
The plow does not angle or angles slowly.	<ol style="list-style-type: none"> 1. Check the hydraulic-fluid level. 2. Check that the power/ground cables and the control cable are connected properly. 3. Check the wiring on the valve block for proper connections. 4. Load a test battery. 5. Check the ANGLE control solenoid valve. 	<ol style="list-style-type: none"> 1. The hydraulic-fluid level should be within 2 cm (3/4 inch) of the top of the reservoir when lowered. 2. Connect the cables if they are not connected. 3. Refer to the manifold wiring diagram included with your <i>Owner's Manual</i>. 4. Replace the battery if it is weak or defective. 5. If the ANGLE solenoid valve is not opening completely, replace it.
Oil leaks from the lift cylinders.	<ol style="list-style-type: none"> 1. Inspect the fittings and O-rings. 2. Check the rod condition. 	<ol style="list-style-type: none"> 1. Tighten loose fittings. See your authorized BOSS dealer for a seal kit. 2. If the rods are pitted or rough, polish them with a copus cloth or extra fine steel wool.
The vehicle battery dies when all of the switches are in the NEUTRAL position.	<ol style="list-style-type: none"> 1. Inspect the controller wiring for a short. 2. Inspect the wire harness for a short. 3. Inspect the valve coils for a short. 	<ol style="list-style-type: none"> 1. If there is a short, repair or replace the controller. 2. If there is a short, repair or replace the wire harness. 3. If there is a short, replace the valve coils.
The plow does not clean up snow from low areas.	<ol style="list-style-type: none"> 1. The controller is not in the FLOAT position. 	<ol style="list-style-type: none"> 1. Activate the FLOAT feature on the controller.
The vehicle battery dies when the vehicle is turned off.	<ol style="list-style-type: none"> 1. Verify that the plow was installed to a keyed fuse source. 	<ol style="list-style-type: none"> 1. Refer to the wiring diagram included with your <i>Owner's Manual</i>.
The plow does not clean up snow from low areas.	<ol style="list-style-type: none"> 1. The controller is not in the FLOAT position. 	<ol style="list-style-type: none"> 1. Activate the FLOAT feature on the controller.

Problem	Possible Cause	Corrective Action
Fluid is running out of the fill cap of the hydraulic pump.	<ol style="list-style-type: none"> 1. Power the light tower down. Do not pull the tower down. 2. The terrain is too steep. 3. The pump reservoir is overfilled. 4. The plow is hitting snowbanks too hard. 	<ol style="list-style-type: none"> 1. Disconnect the plow and adjust the hydraulic-fluid level. 2. Avoid steeply sloped areas. 3. The hydraulic fluid level should be within 2 cm (3/4 inch) of the top of the reservoir. 4. Do not plow recklessly.
The pump chatters when raising the plow or extending the wing(s).	<ol style="list-style-type: none"> 1. Make sure that the vehicle is on and the controller is in the FLOAT position. 2. Make sure that the controller is in the FLOAT position. 3. Check valve block and the SmartHitch2 switch for proper connections. 	<ol style="list-style-type: none"> 1. Turn the vehicle on and put the controller in the FLOAT position. 2. If the controller comes out of the FLOAT position when using the SmartHitch2 controller, replace the controller. 3. Refer to the manifold wiring diagram included with your <i>Owner's Manual</i>.
The SmartHitch2 doesn't attach to the plow.	<ol style="list-style-type: none"> 1. Make sure that the vehicle is on and the controller is in the FLOAT position. 2. Make sure that the controller is staying in the FLOAT position. 3. Check valve block and the SmartHitch2 switch for proper connections. 	<ol style="list-style-type: none"> 1. Turn the vehicle on and put the controller in the FLOAT position. 2. If the controller comes out of the FLOAT position when using the SmartHitch2 controller, replace the controller. 3. Refer to the manifold wiring diagram included with your <i>Owner's Manual</i>.

Schematics

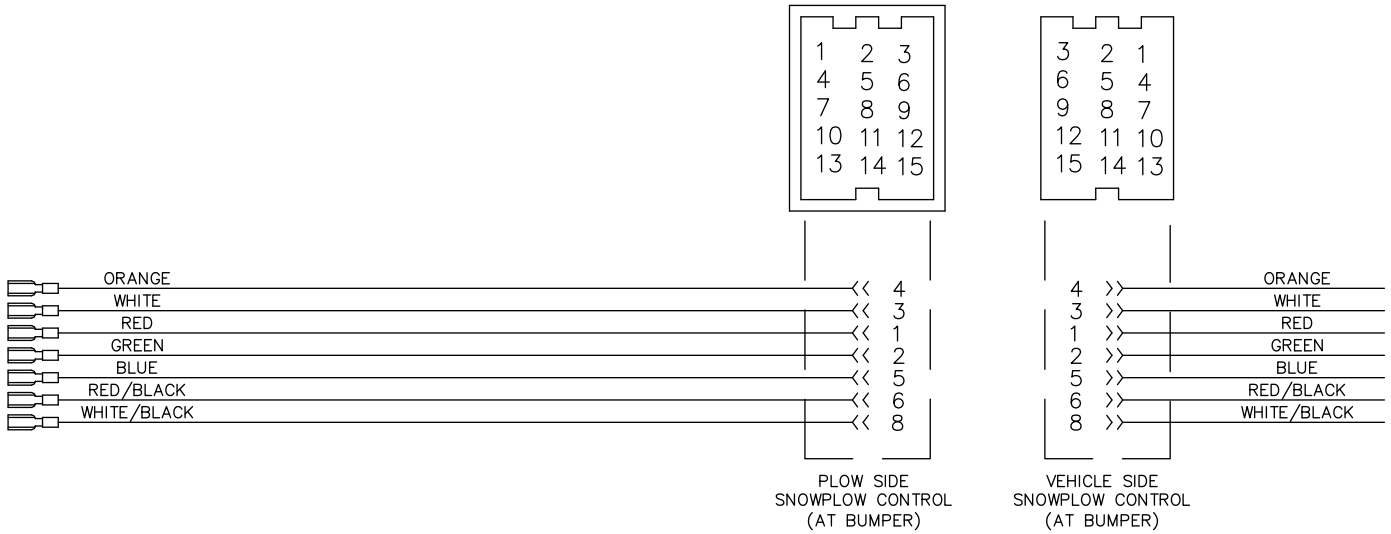
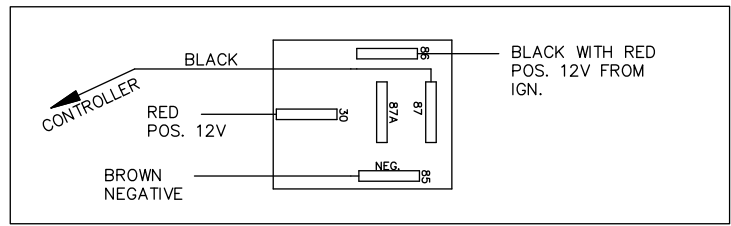

Plow Side Electrical Schematic (Rev. 0)

G038232

RELAYS
MSC04294
(SEE RELAY DETAIL)

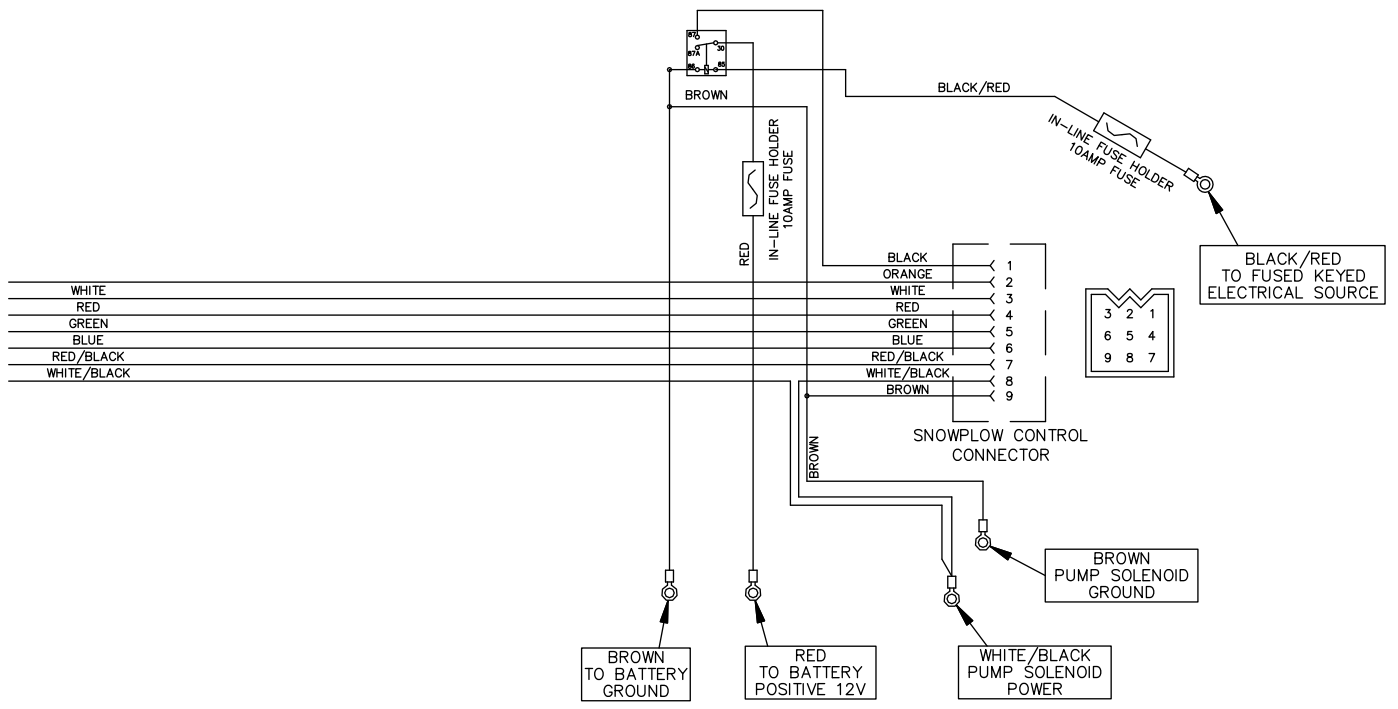

038233

Truck Side Electrical Schematic (Rev. 0)

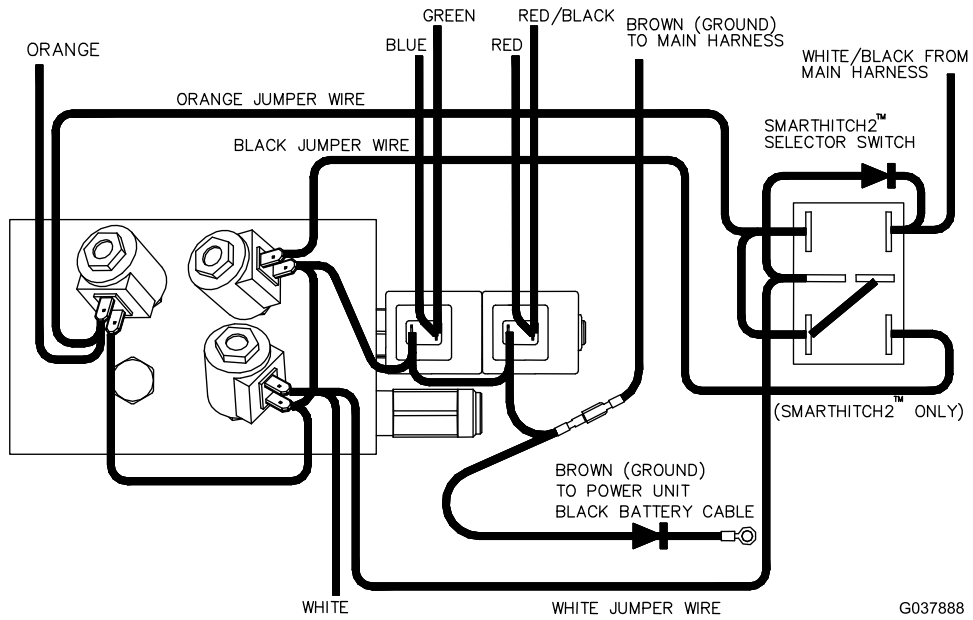

G037888

Wire Color	Function
Green	Blade left
Red	Blade right
White	Lift
Orange	Lower
Red/Black	Blade right
Blue	Blade left
Black	SmartHitch2
Brown	Ground

Hydraulic Manifold (Rev. 0)

Notes:

BOSS Products Commercial Warranty

What this warranty covers:

This warranty covers defects in material and workmanship except as set forth below.

Who is covered:

The original purchaser from an authorized dealer.

For how long:

Complete Product: 2 years from the date of purchase.

Labor: 2 years from the date of purchase for complete product.

Parts: 1 year from the date of purchase. (no Labor)

What BOSS Products will do:

BOSS Products will, at its sole option, repair or replace defective parts at no charge.

What you must do for warranty service:

To obtain warranty service, purchaser must return the defective product to any authorized BOSS Products dealer (preferably the one from whom the product was purchased) within the warranty period. Purchaser must be able to verify the original purchase date. All transportation costs to and from the dealer will be the responsibility of the purchaser. To locate the authorized BOSS dealer nearest to you, call toll free: (800) 286-4155.

What is not covered:

1. Expendable parts such as hoses, plow shoes, cutting edges, pins, nuts, bolts, blade guides, etc.
2. Products repaired or altered by anyone other than an authorized BOSS Products dealer.
3. Products which have been subject to misuse, negligence, accident, improper installation, maintenance, care, or storage.
4. Products mounted on vehicles other than those listed in the *BOSS Snowplow Application Chart and Selection Guide*.
5. BOSS Products does not assume liability for damage to your motor vehicle resulting from the attachment or use of any BOSS products. Vehicle risk is the sole responsibility of the purchaser.

Limits of BOSS Products Liability are:

BOSS Products' liability is expressly limited to repair or replacement of defective parts. BOSS Products shall not be liable for consequential, incidental, or contingent damages whatsoever, even if damages are caused by the negligence or fault of BOSS Products. The foregoing warranties are exclusive and in lieu of all other express and implied warranties including, but not limited to, the implied warranties of merchantability and fitness for a particular purpose.

This warranty does not apply if you purchased your product for personal, family, or household use. In this case, refer to the BOSS Products Limited Consumer Warranty.

BOSS Products is a division of
The Toro® Company
P.O.Box 787 2010 The BOSS Way
Iron Mountain, MI 49801

(2016-2017)

BOSS Products Consumer Warranty

What this warranty covers:

This warranty covers defects in material and workmanship except as set forth below.

Who is covered:

The original retail purchaser of a BOSS product who purchases it for personal, family, or household use.

For how long:

Complete Product: 2 years from the date of purchase.

Labor: 2 years from the date of purchase for complete product.

Parts: 1 year from the date of purchase. (no Labor)

What BOSS Products will do:

BOSS Products will, at its sole option, repair or replace defective parts at no charge.

What you must do for warranty service:

To obtain warranty service, purchaser must return the defective product to any authorized BOSS Products dealer (preferably the one from whom the product was purchased) within the warranty period. Purchaser must be able to verify the original purchase date. All transportation costs to and from the dealer will be the responsibility of the purchaser. To locate the authorized BOSS dealer nearest to you, call toll free: (800) 286-4155.

What is not covered:

1. Expendable parts such as hoses, plow shoes, cutting edges, pins, nuts, bolts, blade guides, etc.
2. Products repaired or altered by anyone other than an authorized BOSS Products dealer.
3. Products which have been subject to misuse, negligence, accident, improper installation, maintenance, care, or storage.
4. Products mounted on vehicles other than those listed in the *BOSS Snowplow Application Chart and Selection Guide*.
5. BOSS Products does not assume liability for damage to your motor vehicle resulting from the attachment or use of any BOSS products. Vehicle risk is the sole responsibility of the purchaser.

Limits of BOSS Products Liability are:

BOSS Products' liability is expressly limited to repair or replacement of defective parts. BOSS Products shall not be liable for consequential, incidental, or contingent damages whatsoever, even if damages are caused by the negligence or fault of BOSS Products. The foregoing warranties are exclusive and in lieu of all other express and implied warranties including, but not limited to, the implied warranties of merchantability and fitness for a particular purpose.

State laws:

Some states do not allow exclusion of incidental or consequential damages or the limitations on how long an implied warranty lasts, so these limitations or exclusions may not apply to you. This warranty gives you specific legal rights and you may also have the other rights which vary from state to state.

This warranty does not apply if you purchased your product for personal, family, or household use. In this case, refer to the BOSS Products Limited Consumer Warranty.

BOSS Products is a division of
The Toro® Company
P.O.Box 787 2010 The BOSS Way
Iron Mountain, MI 49801

(2016-2017)