

ANTHONY
LIFTGATES, INC.®

LA-86



INSTALLATION, OPERATION, AND MAINTENANCE



QUALITY, RELIABILITY, CUSTOMER SERVICE

MADE IN THE USA 

Contents

1. General Information Section	4
1.1 Introduction	4
1.2 Important Operation Notes	4
1.3 Model Information	4
1.4 Installation Recommendations	5
1.5 Warranty	5
1.6 Decals	6
1.7 Ordering Parts	6
2. Safety Section	7
2.1 Safety is Your Responsibility	7
2.2 Safety Signal Words	7
2.3 Safety Rules	7
2.4 Safety Icons Nomenclature	9
2.4.1 Personal Protection/Important Information	9
2.4.2 Prohibited Actions	9
2.4.3 Hazard Avoidance	9
3. Nomenclature	10
3.1 Platform nomenclature	10
3.2 Power Unit nomenclature	10
4. Installation Section	11
4.1 Basic Mounting Information	11
4.2 Tools Required	11
4.3 Check the Shipment	11
4.4 Installation Procedure	12
4.5 Installation on Flatbed Truck	18
4.6 Battery Connection	19
4.6.1 Direct Battery Connection (not recommended)	19
4.6.2 Cut-Off Solenoid Connection	20
4.6.3 Cut-Off Switch Connection	20
4.7 Cable Lug Installation	21
4.8 Final Inspection Checklist	21
5. Decals	22
6. Operation Section	24
6.1 General Operating Safety	24
6.2 Operating Instructions	25
6.2.1 Opening and Closing the Liftgate	25
7. Maintenance Section	26
7.1 Preventive Maintenance	26
7.1.1 Monthly Inspection	26
7.1.2 Semi-Annual Inspection	27
7.2 Maintenance And Troubleshooting Procedures	28
7.2.1 Replacing the Fuse	28
7.2.2 Checking the Lowering Valve Cartridge and Coil	28
7.2.3 Checking Motor Start Solenoid and Power Cut-off Solenoid	29
7.2.4 Inspecting the Cylinder Piston Rod Seals	29
7.2.5 Checking the Relief Valve	29
7.2.6 Flow Control Valve	30
7.3 Troubleshooting Chart	31
7.4 Inspection Record	33
8. Limited Warranty	34
8.1 Limited Warranty	34
8.2 Warranty Policy and Procedure	34

1. General Information Section

1.1 Introduction

Congratulations on selecting an Anthony LA-86 Liftgate for van bodies and stake bed trucks. Anthony liftgates are among the finest available on the market today. This manual will provide you with the necessary instructions and safety precautions to correctly install and operate this liftgate.

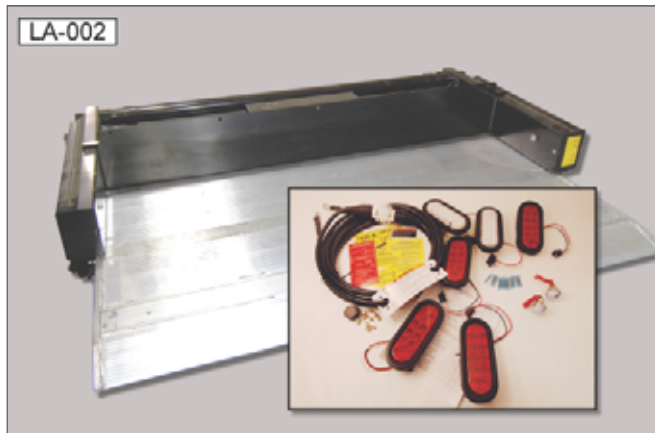

1.2 Important Operation Notes

A platform restraining system may be needed to retain certain types of cargo on the liftgate platform, such as a cart stop, straps, etc. This should be considered by the purchaser for their particular application to prevent the possibility of severe personal injury or death due to cargo shifting and/or falling from the liftgate platform.

All users of this liftgate must be at least 18 years old and have read and understood all operation instructions and safety decals before use.

WARNING



CRUSH HAZARD

Unsecured loads, when moved on the liftgate, can shift or fall.

To prevent personal injury or death, make sure loads are securely fastened to liftgate or restrained by cart stops, retention ramp, or fencing.

1.3 Model Information

The LA-86 Liftgate provides up to 54 inches of total lift height with a lifting capacity of 2000 pounds. A large 85" wide by 41" deep platform easily handles most loads. A 6" tapered ramp makes loading and unloading easier.

The platform of the LA-86 Liftgate is constructed of lightweight, corrosion resistant aluminum. It also has an anti-slip surface.

Each platform has dual, foot-operated cart stops to prevent an accidental loss of a load from the platform. The stops are easily engaged by simply kicking the latch mechanism.

The E-Z Mount design comes completely assembled and factory tested. This unit can be quickly and easily installed on almost any van body or stake bed truck.

With the proper tools and two installers, the liftgate can be installed in two to three hours (4 to 6 total manhours).

All Anthony LA-86 model liftgates are factory assembled, tested, and energized to ensure the highest quality performance standards.

This Installation, Operation, and Maintenance manual will provide you with easy-to-follow instructions, along with photos and illustrations. All Safety precautions have been clearly identified and detailed throughout each section.

In addition to the installation instructions, a complete explanation of the safety words and rules are included in the Safety Section of this manual. Please turn to the Safety Section and read it thoroughly before proceeding to the next page.

1.4 Installation Recommendations

Even though the following goes without saying, we feel compelled to state:

Anthony Liftgates should only be installed by those with sufficient skills to understand the installation and operation of the liftgate, along with the equipment required to install the liftgate. The installation instructions in this manual are intended to give typical installation instructions to the installer for both the operation and what we believe to be the most desirable sequence of installation. These instructions cannot replace a qualified person, or clear thinking and the basic knowledge that must be possessed by the installer.

We urge the installer (or anyone else) to call us if they have any questions. We have qualified personnel at our Pontiac, Illinois plant to answer any questions that you may have. Sometimes, a detailed discussion on the phone can be far more satisfactory than a detailed written explanation.

It has been our experience that a knowledgeable person following these installation instructions and observing the operation of the liftgate will have sufficient comprehension of the liftgate to enable this person to troubleshoot and correct all normal problems that may be encountered.

However, again we urge you to call us at our Pontiac, Illinois plant if you find the liftgate is not operating properly or if you do not know how to make the necessary repair.

If you have any concerns or questions, call us at:

Anthony Liftgates, Inc.
1037 West Howard Street
Pontiac, Illinois 61764
(815) 842-3383 or 800-482-0003
www.anthonyliftgates.com

⚠ WARNING



PROPER INSTALLATION

The success or failure of this liftgate to properly and efficiently operate will depend on a thorough and proper installation. Failure to read, understand, and follow the installation instructions and safety recommendations in this manual before installing the liftgate can result in serious injury or death. Also read and understand the operating instructions in the Operation Section.

When installed, this liftgate must not alter nor prevent vehicle compliance to any existing state or federal standards, and especially FMVSS 105. Each chassis manufacturer's recommendations should be consulted for compliance. Also make sure the weight of the liftgate and its load will not overbalance the truck, possibly raising the front wheels off the ground.

1.5 Warranty

⚠ WARNING

VOIDED WARRANTY

The liftgate must be installed according to the installation instructions or the warranty will be void. Unauthorized modifications of the liftgate may cause it to improperly operate or cause other unforeseen problems or dangers that may cause serious injury or death. If any deviation is deemed necessary, written permission must first be obtained from Anthony Liftgates.

All decals must be in place and legible or all warranties are void.

Before calling for warranty or other product information, have the serial number, model number, and lift capacity of your liftgate, which is stamped into the identification plate on the streetside of the liftgate.



Serial Number Identification Plate.

Record the serial number, model number, and date of installation for easy reference when contacting Anthony Liftgates with questions.

Serial Number Information	
Serial No.	
Model No.	
Date of Installation	

Refer to "8.1 Limited Warranty" on page 34 for the complete warranty statement.

1.6 Decals

SAFETY INSTRUCTIONS



LEGIBLE SAFETY SIGNS

To prevent possible injuries due to improper operation, make sure all safety signs (decals) are attached to the liftgate and/or truck and are legible at all times.

Safety decals provide a vital role in helping reduce injury and/or death. To ensure the greatest level of safety, all decals must be attached to the liftgate and be legible at all times. Remember, it is the users' responsibility to maintain these decals. For decal placement, and a complete part number list and illustration of the decals used on the liftgate, refer to "5. Decals" on page 22 in this manual.

For replacement decals contact:

**Anthony Liftgates, Inc.
1037 West Howard Street
Pontiac, Illinois 61764
(815) 842-3383 or 800-482-0003
www.anthonyliftgates.com**

1.7 Ordering Parts

We manufacture a quality liftgate that requires very little maintenance or repair. However, should a part break, become damaged, or worn, our knowledgeable staff can make sure you receive the part(s) to put your liftgate back into operation.

Note: The liftgate's packet of information does not contain a "parts manual." The most current and up-to-date parts manuals can be obtained by accessing our website anytime.

Our website address is **www.anthonyliftgates.com**
Click on "Manual" and choose a model.

If you do not have access to the internet, or just prefer a printed copy of a manual, we can send one to you. Call or write our office listed below.

For questions or to order parts, contact:
**Anthony Liftgates, Inc.
1037 West Howard Street
Pontiac, Illinois 61764
(815) 842-3383
Email: Sales@anthonyliftgates.com**

2. Safety Section

2.1 Safety is Your Responsibility



It is the responsibility of the installer/operator to understand and perform proper operating procedures. Be aware of the inherent dangers in the use of this product and the tools used to install it. Read and understand all Danger, Warnings, Cautions, and Important Notices in this manual and on the liftgate or truck.

2.2 Safety Signal Words



This is the safety alert symbol. It is used to alert you to potential personal injury hazards. Obey all safety messages that follow this symbol to avoid possible injury or death.

This manual contains DANGERS, SAFETY INSTRUCTIONS, CAUTIONS, IMPORTANT NOTICES, and NOTES which must be followed to prevent the possibility of improper service, damage to the equipment, personal injury, or death. The following key words call the readers' attention to potential hazards.

Hazards are identified by the "Safety Alert Symbol" and followed by a signal word such as "DANGER", "WARNING", or "CAUTION".

DANGER

Indicates an imminently hazardous situation which, if not avoided, will result in death or serious injury. This signal word is limited to the most extreme situations.

WARNING

Indicates a potentially hazardous situation which, if not avoided, could result in death or serious injury.

CAUTION

Indicates a potentially hazardous situation which, if not avoided, may result in minor or moderate injury.

NOTICE

Indicates that equipment or property damage can result if instructions are not followed.

SAFETY INSTRUCTIONS

Safety instructions (or equivalent) signs indicate specific safety-related instructions or procedures.

Note: Contains additional information important to a procedure.

2.3 Safety Rules

Accidents can often be avoided by being alert and recognizing potentially hazardous situations. Any individuals installing, operating, repairing, or maintaining products manufactured by Anthony Liftgates should have the necessary training, skills, and tools required to perform these functions properly and safely. The safety information in this manual serves as a basic guide in an attempt to prevent injury or death.

Anthony Liftgates cannot anticipate every possible circumstance that might involve a potential hazard. The warnings in this manual and on the product itself are, therefore, not all-inclusive. If tools, procedures, work methods, or operating techniques that are not specifically mentioned by Anthony Liftgates are used, you must satisfy yourself that they are safe for you and for others. Make sure the liftgate or truck it is mounted onto will not be damaged or made unsafe by any operation, lubrication, maintenance, or repair procedures that you choose.

DO NOT proceed, if any doubt arises about the correct or safe method of performing anything found in this or other Anthony Liftgates manuals. Seek out expert assistance from a qualified person before continuing.

WARNING



To avoid personal injury or death, carefully read and understand all instructions pertaining to the Anthony Liftgates product. Do not attempt to install, operate, or maintain our product without fully understanding all of our instructions and safety recommendations. Do not operate or work on a truck or liftgate unless you read and understand the instructions and warnings in the Installation and Operation manual. If any doubt or question arises about the correct or safe method of performing anything found in this or other Anthony Liftgates' manuals, contact your Anthony Liftgates' dealer or call the Inside Sales and Service representatives at our main headquarters. Proper care is your responsibility.

⚠ WARNING



To prevent serious bodily injury, keep sparks, lighted matches, and open flames away from the top of the battery, because battery gas can explode. Always follow all the manufacturers' safety recommendations when working around the truck's battery.



Take precautions to avoid sparks coming into contact with the truck's fuel tank, brake lines, or other flammable components. Sparks can cause an explosion of combustible materials, resulting in serious injury or death.



Never secure the power cable to anything which allows it to contact sharp edges, other wiring, the fuel tank, fuel lines, brake lines, air lines, exhaust system, or any other object that could cause the power cable to wear or be damaged. A cut battery cable can cause sparks resulting in loss of vehicle control, serious injury, or even death.



If required for installation, always use a cutting torch in a well ventilated area and, if in an enclosed area, vent the fumes to the outside. Breathing the smoke and fumes can cause serious injury.



Always follow all State and Federal health and safety laws and/or local regulations when using a cutting torch. Also, follow all manufacturer's safety guidelines. If other people are present during the installation of the liftgate, make sure they remain clear of the cutting area.



To avoid eye injury, always wear eye protection with the proper lens to protect your eyes.



Failure to prevent the truck from moving during the installation of the liftgate could result in a serious crushing injury.



Do not work under the liftgate while it is suspended from the lifting equipment. Failure of the lifting equipment could cause serious crushing injuries. Do not remove the lifting equipment until the liftgate is completely bolted onto the truck frame.



To prevent personal injury, clean up any spilled fluids immediately. To avoid tripping, do not leave tools or components laying around in the work area.

⚠ CAUTION



Anthony Liftgates recommends not riding the liftgate, however, if the delivery operation requires it, make sure your footing is stable before raising or lowering platform. Always stand away from the edge. When on the ground, always stand clear of liftgate when it is operating.



Always use/set the truck's parking brake before operating the liftgate. Failure to follow this recommendation can result in injury.



Do not place hands or feet in pinch points.



Do not place your feet under the liftgate.

SAFETY INSTRUCTIONS



To prevent injury, the liftgate and its related components should only be installed by a qualified installer. They should have knowledge and skill in using lifting equipment and a cutting torch.











To prevent possible injuries due to improper operation, make sure all decals are attached to the liftgate and/or truck and are legible at all times.



2.4 Safety Icons Nomenclature

This manual and the equipment has numerous safety icons. These safety icons provide important operating instructions which alert you to potential personal injury hazards.

2.4.1 Personal Protection/Important Information

-  Read the manual
-  Use proper tools
-  Damaged safety signs
-  Inspect equipment
-  Use two people when lifting heavy objects
-  Eye protection
-  Breathing protection
-  Set parking brake

2.4.2 Prohibited Actions

-  No smoking
-  No open flame

2.4.3 Hazard Avoidance

-  Slipping injury
-  Tripping injury
-  Safety alert symbol
-  Explosion hazard
-  Pinch point hazard
-  Explosion hazard
-  Dangerous fumes
-  Chock wheels
-  Adequate ventilation
-  Crush hazard
-  Crush hazard
-  Crush hazard (chock wheels)
-  Cutting hazard
-  Fall hazard
-  Crush hazard (foot)

3. Nomenclature

3.1 Platform Nomenclature

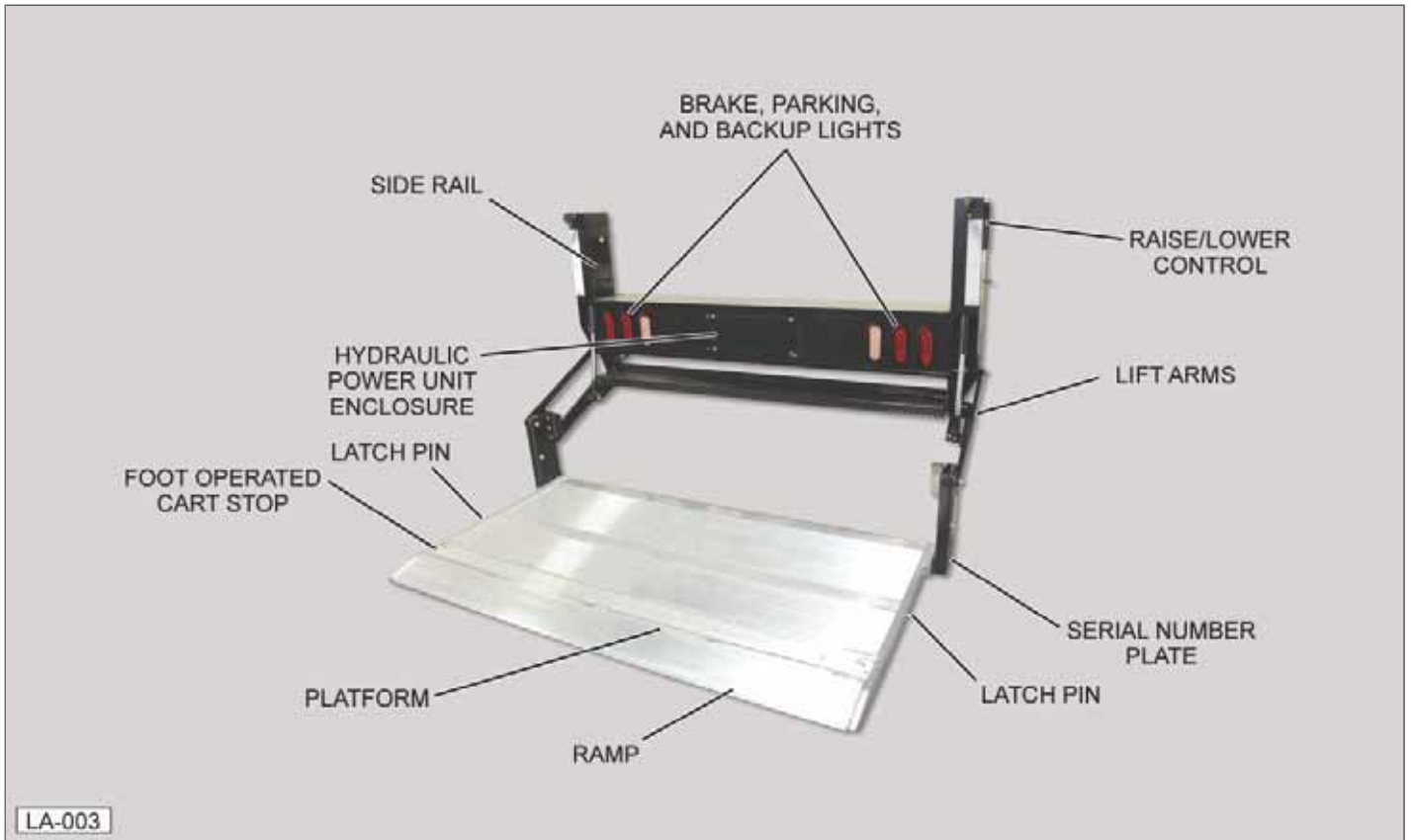

3.2 Power Unit Nomenclature

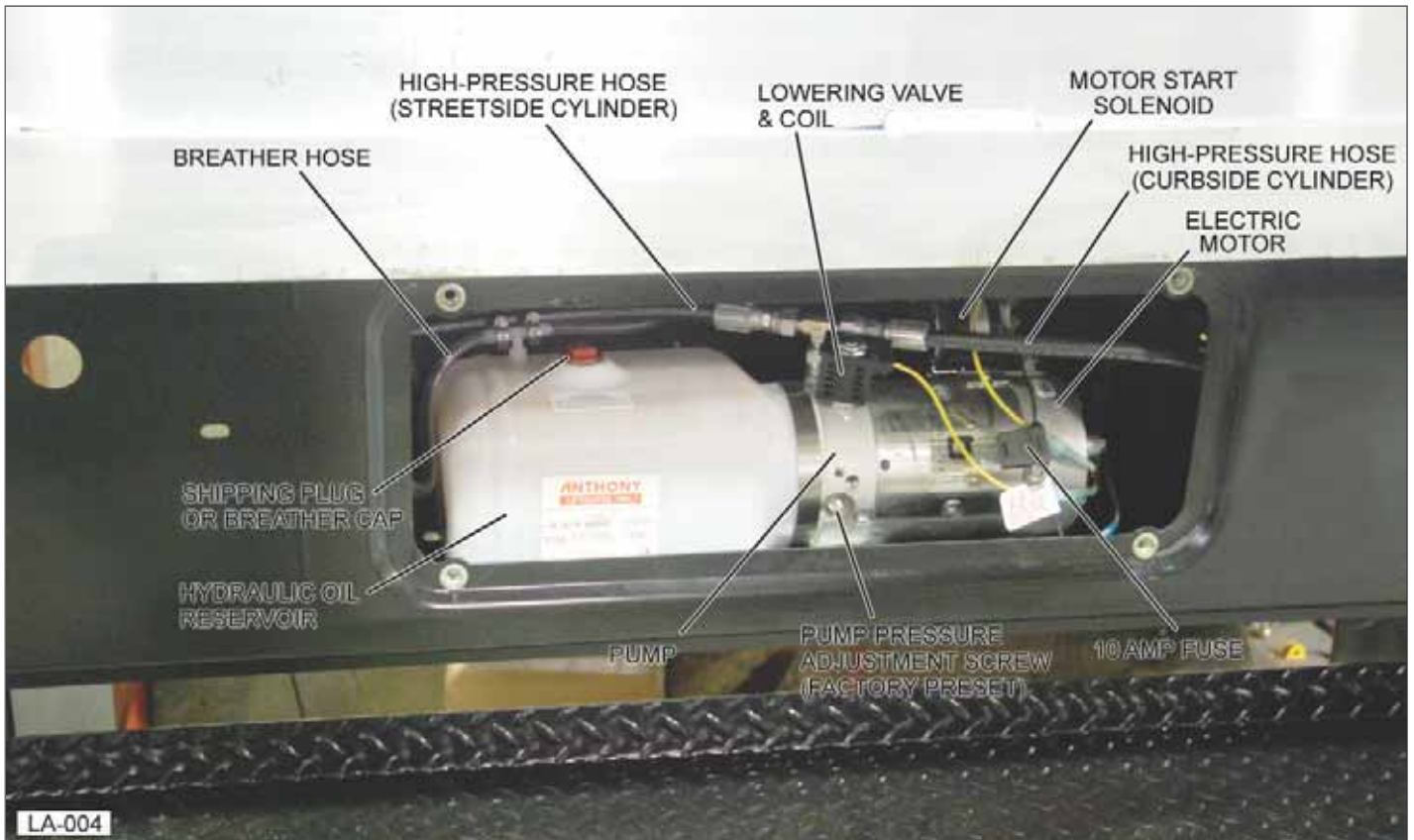

4. Installation Section

4.1 Basic Mounting Information

The LA-86 Liftgate is intended for installation on a van body or stake bed truck.

If the liftgate is installed on the van body of a straight truck, re-tighten the U-bolts that secure the van body to the chassis.

Note: DO NOT attempt to install the liftgate on a flatbed or stake bed truck without consulting the factory to determine feasibility.

If installing the unit on a stake bed truck, it requires the addition of diagonal braces to connect the rails of the liftgate to the bed of the truck. **These diagonal braces are not part of the kit and must be provided by the installer. Refer to the section "Installation on Flatbed Trucks" for further details.**

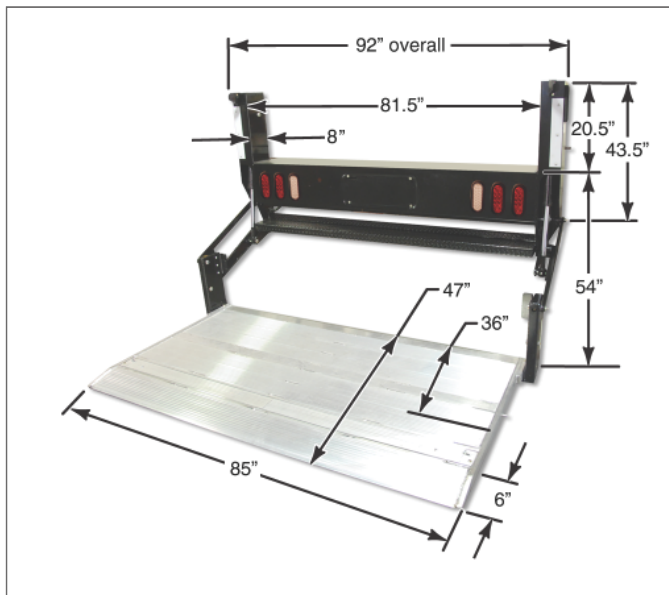

SAFETY INSTRUCTIONS



Even though the Anthony liftgate is easy to install, the installation should be done with at least two people.

4.2 Tools Required

The following is a list of suggested tools and equipment that should be used to install the liftgate.

- Overhead crane or forklift
- Mig or stick welder
- Heavy-duty clamps
- Tape measure
- Open end wrenches
- Nut driver (grease zerks)
- Chain or sling and lifting hooks

4.3 Check the Shipment

You should have the following items for this shipment to be complete.

- Liftgate assembly
- Power cable with in-line fuse
- Miscellaneous parts box including:
 - Four red taillights with rubber grommets
 - Two clear backup lights with rubber grommets
 - One license plate light
 - Twelve electrical wire connectors
 - Ten grease zerks
 - One hydraulic tank breather cap
 - One set of warning decals
 - One Installation and Operation manual

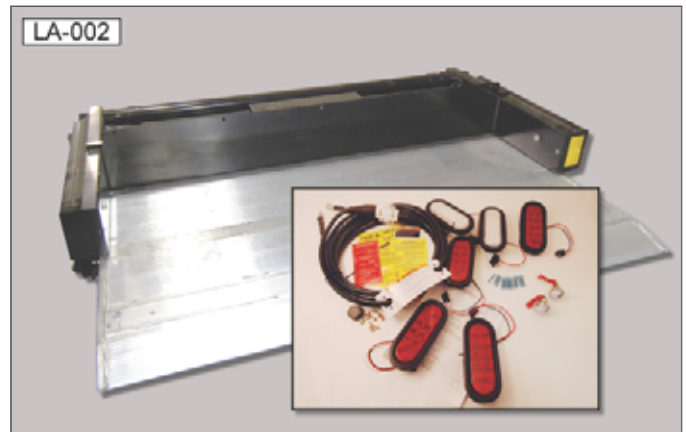

4.4 Installation Procedure

1. Place the truck on a flat, level surface. The rear surface of the truck must be straight and square.

! WARNING



ROLLOVER HAZARD

Failure to prevent the truck from moving during the installation of the liftgate could result in serious personal injury or crushing of the installer(s).

2. Block the wheels to prevent possible truck movement during liftgate installation.
3. Remove any shipping bands securing the liftgate to the shipping pallet. Remove the box containing the miscellaneous loose parts.
4. Remove all obstructions from the rear of the truck that would interfere with the operation or installation of the liftgate. Obstructions may include dock bumpers, ICC bumpers, taillights, door hinges, latches, or any other protrusions.
5. Make sure the proper required bumper (ICC or REAR UNDERRIDE) is in place and meets all Federal Regulations.

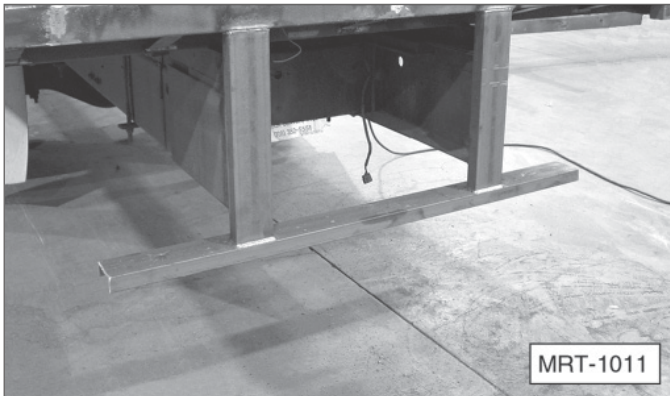

! CAUTION



KEEP AREA CLEAR

Make sure the area where the platform will be functioning (up, down, open, and close) is free of obstructions and people before operating the liftgate.

6. Make sure the corner post of the van body will support the weight of the liftgate. If the corner posts are made from aluminum, contact Anthony Liftgates for additional information.
7. Make sure the corner posts of the van body and the side rails of the liftgate are clean and free of dirt or paint before welding.

! WARNING



CRUSH HAZARD

To avoid personal injury, do not work under the platform during installation. Work so you are not in the way if a lifting device, clamps, welds, etc. should fail.

8. Position the liftgate behind the truck, as shown.



9. Attach a lifting device to the side rails of the liftgate. On older models, remove the top two bolts and then remove the top plate from both side rails. Newer models are equipped with a lifting hole, as shown.



- Use an adequately sized forklift or hoist to raise the liftgate and place it on the rear of the truck. The liftgate weighs approximately 650 pounds.



⚠ WARNING



NEVER WORK UNDER LIFTGATE
Do not remove the hoist, fork lift, or other lifting device used to hold the liftgate in place during the installation procedure. Never work under the liftgate PLATFORM while installing or painting the unit. Work so that you would not be in the way if the clamps, weld, etc. should fail.

- Place the lip of the liftgate, indicated by arrow, onto the bed frame and also make sure the liftgate is pushed tightly against the body. Clamps can be used to temporarily hold the liftgate in place prior to tack welding.



⚠ CAUTION



INSUFFICIENT WELDS
The tack welds must be strong enough to hold the weight of the liftgate. Insufficient welds may not hold the liftgate in place, resulting in bodily harm.

- Using 3/16 to 1/4 inch welds, securely tack weld the outside rails of the liftgate to the van body on both sides. Do not remove the lifting device at this time.

NOTICE

Protect the warning decals from damage when welding the liftgate to the truck.

- Remove the center cover and replace the red shipping cap on the hydraulic oil reservoir with the breather cap shipped in the loose parts package.



- Temporarily attach one end of the battery cable to the motor start solenoid, as shown, and the other end to the positive terminal of the battery. Attaching the battery cable will allow the liftgate to be operated and tested before final welding.

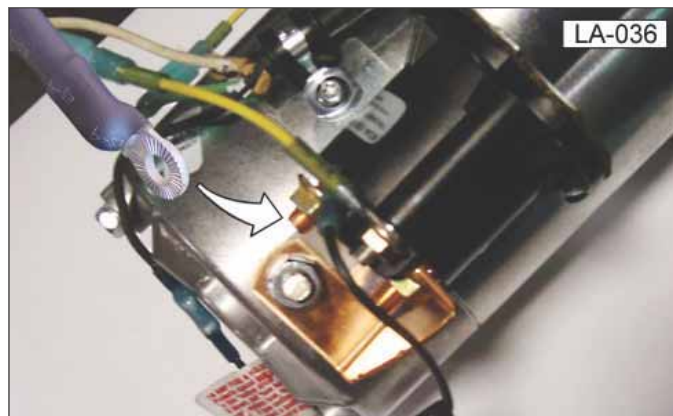

- Remove the hair pin clip from the platform latch pin.



⚠️ WARNING



CRUSH HAZARD

Once the platform latch mechanism is released, the platform is free to fall open. The weight of the platform can cause serious injury if allowed to open (fall) freely. Do not release the platform until it is supported, by hand, to prevent it from falling. Use a second person to help support the platform, if available.

16. Release the latch mechanisms by pulling on the latch release cable. When the latches are released, the platform will open. Make sure you support the platform to prevent it from falling and hurting yourself or a bystander. The downward weight of the platform is approximately 50 pounds.



17. Thoroughly check the position of the liftgate assembly before starting the final welding.
- The liftgate must be centered on the van body.
 - The lip of the liftgate must be flush with the floor.
 - Both side rails must be tight against the rear frame.
 - The side rails must be square with the vehicle body and parallel to each other.

If any of these items are not correct, reposition the liftgate.

⚠️ CAUTION



STAY CLEAR

Make sure the area where the platform will be functioning (up, down, open, and close) is free of obstructions and people before operating the liftgate.

18. This liftgate operates as a power up (raise) and gravity down (lower) unit.

Hold the Raise/Lower switch in the Lower position until the platform lowers to the ground. Now, hold the Raise/Lower switch in the Raise position until the platform raises to bed height. Make sure the liftgate operates smoothly before proceeding. If the liftgate does not operate properly, it could be misaligned. Correct any operating problems before final welding.

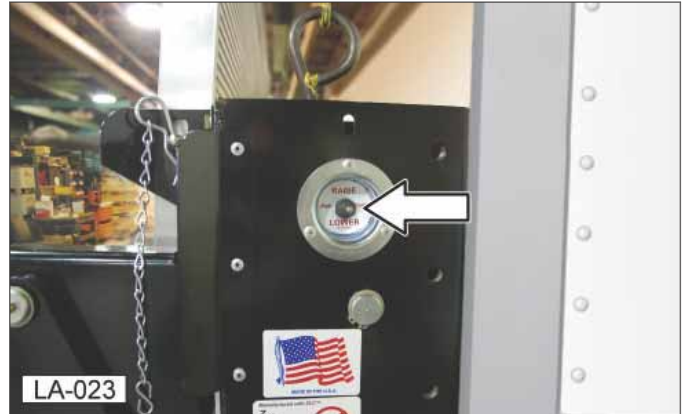

⚠️ CAUTION



For safety purposes, weld the liftgate while the platform is on the ground, not in a raised position. Cover the cylinder rods to prevent weld spatter from damaging them.

NOTICE

Cover the cylinder rods to prevent weld spatter from damaging them when welding the liftgate to the truck.

19. Final weld the liftgate to the van body using eight evenly spaced 3/16" wide by 2" long welds on the bed, four evenly spaced 2" welds on the outside frame, and three evenly spaced 2" welds on the inside frame.

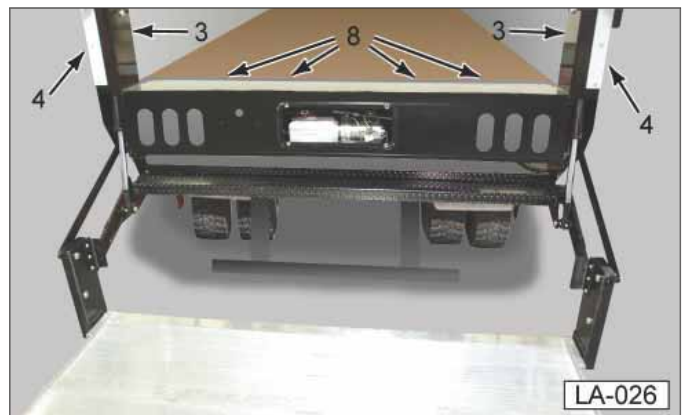

20. Remove the lifting device. On older model liftgates, install the top covers on each side rail using the two bolts previously removed.

21. Install eight grease zerks in the lift arms, four on each side, as shown.

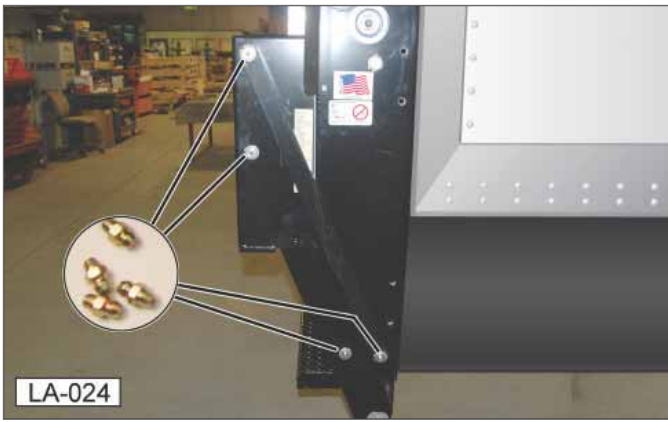

22. Using a nut driver, Install two grease zerks in the platform, one on each side, as shown.

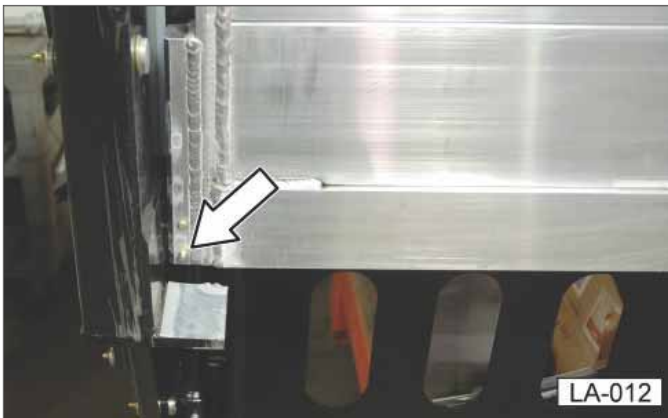

WARNING



CUTTING HAZARD

The cart stop is spring operated and quickly opens when the latch mechanism is released. Do not use your fingers or hand to release the latch, as this can result in serious injury.

23. Check the operation of the cart stop. Release the cart stop latch using your foot. Do not release the latch using your hand or fingers.



24. Raise and place the platform in the transport position. Install the hair pin clip in the latch pin.

Note: Only close the platform when the liftgate is in a fully raised position.

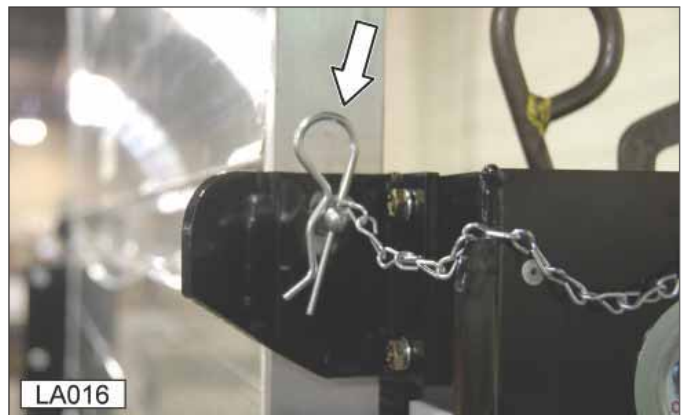

25. If the liftgate will not be painted, remove the protective coating from the two decals, as shown. Also place the other decals, part of the loose parts package, onto the truck. Make sure the decals are placed on the truck and visible to anyone operating the liftgate.



26. Install six rubber grommets into the metal openings for the brake and backup taillights.



27. Install the four red brake/taillights in the outer two openings on each side. Install the white backup lights in the center two openings.



28. Connect the liftgate taillight electrical connectors to the vehicle taillight cables. Make sure the connection is watertight.

29. Install the license plate light, as shown.

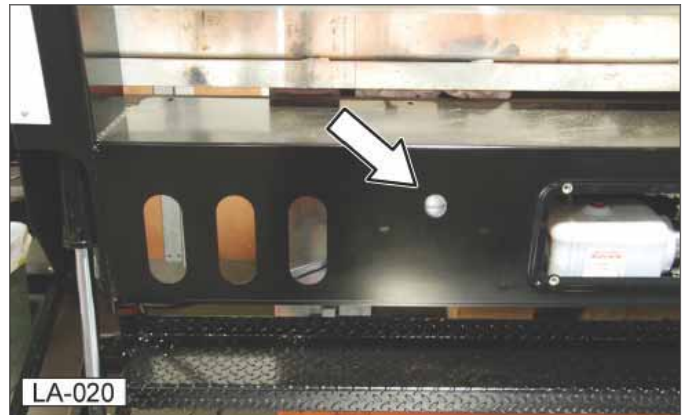

30. Route and connect the battery cable using one of the following three methods.

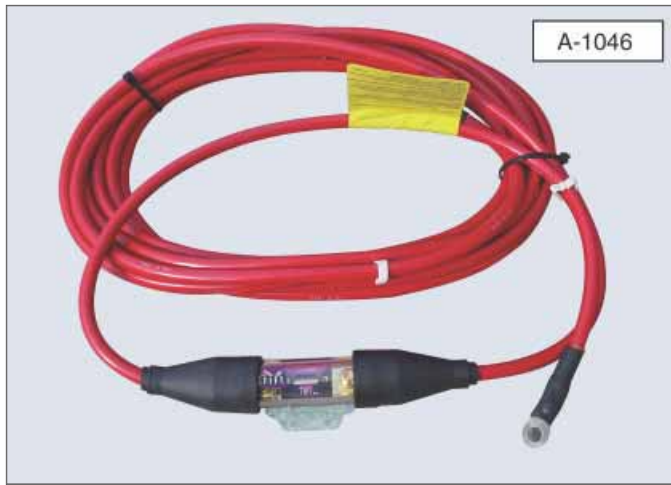

- Direct Battery Connection (not recommended). Refer to “4.6.1 Direct Battery Connection (not recommended)” on page 19.
- Cut-Off Solenoid Connection. Refer to “4.6.2 Cut-Off Solenoid Connection” on page 20.
- Cut-Off Switch Connection. Refer to “4.6.3 Cut-Off Switch Connection” on page 20.

Only one method is required to complete the wiring installation.

WARNING



LOSS OF VEHICLE CONTROL

Never secure the power cable to anything which allows it to contact sharp edges, other wiring, fuel tank, fuel lines, brake lines, air lines, exhaust system, or any other object that could cause the power cable to wear or be damaged. A direct short in the battery cable can cause sparks, resulting in loss of vehicle control, serious injury, or even death.

31. Position the fuse assembly near the battery so the short cable end will reach the positive terminal of the battery. Do not attach the cable to the battery post at this time.

32. Attach the fuse holder to the truck body long sill using either Method A or B, shown in this step.

Method A

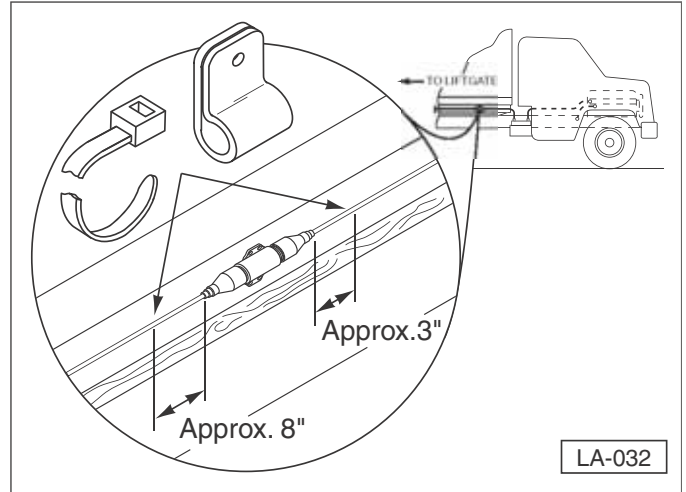

Fasten the power cable to the truck body. Locate one fastener (battery side) within 3 inches of the end of the fuse assembly. Locate the other fastener (power unit side) within 8 inches of the fuse assembly. Using this method does not require the fuse assembly to be attached to the long sill.

Method B

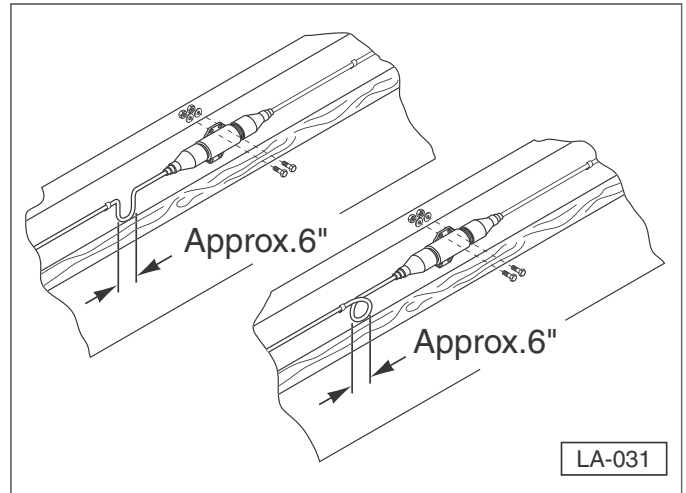

Attach the fuse holder to the truck body long sill using #10 or #12 self-tapping screws or bolts, washers, and self-locking nuts. Fasten the power cable, as needed, to properly hold it in place. Using this method requires an extra length of cable on one side of the fuse assembly to permit removal of the fuse.

33. Route the long end of the power cable from the fuse to the motor solenoid on the power unit of the liftgate. If the power cable is longer than required, it can be cut to the desired length. It can also be looped and attached to the frame. If the cable is cut, attach a cable lug according to “4.7 Cable Lug Installation” on page 21.

34. Connect the power cable to the motor solenoid. Make sure the power cable is connected to the correct motor solenoid post (one not connected to the motor housing with a metal strap or wire cable).

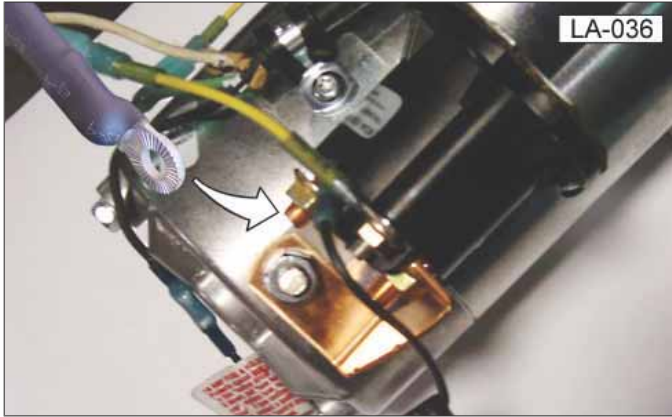

35. Connect the short end of the power cable to the positive post of the battery.
36. The power unit should now be operational. Coat all terminal ends, studs, and nuts with a Teflon lubricant, grease, or other electrical connection sealant to prevent corrosion.
37. Make sure the power unit reservoir is filled. The fluid level should be 1/2" from the top of the reservoir when the liftgate platform is on the ground.



38. Install the hydraulic unit enclosure cover.
39. If available, attach the license plate to the liftgate.
40. Touch up all welds with black paint to prevent rust. Attach all decals, as shown in "5. Decals" on page 22.
41. Complete "4.8 Final Inspection Checklist" on page 21.

4.5 Installation on Flatbed Truck

When installing the liftgate on flat or stake bed truck bodies, two sets of diagonal braces (two upper and two lower) are required. Diagonal braces are made from 2-1/2" sq. tube x 1/8" wall thickness or other similar material. These tubes can be ordered from Anthony Liftgates, Inc.

! WARNING



CRUSH HAZARD

It is the responsibility of the installer(s) to ensure the steel diagonal braces will support the weight of the liftgate and its potential load. Failure of the braces may result in serious crushing injury or death of the installer(s).

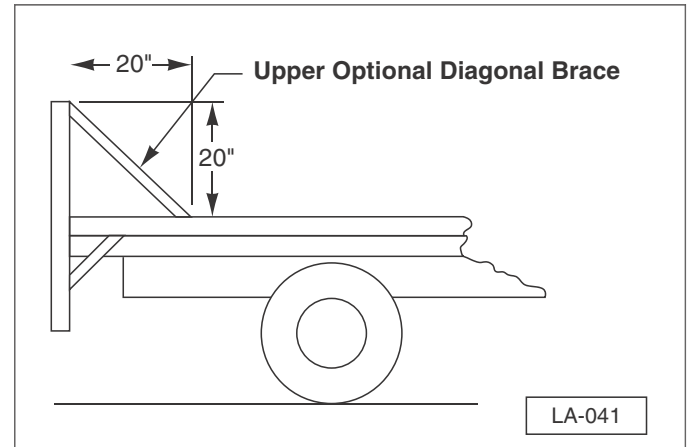

1. Weld the liftgate to the truck bed. Refer to the normal installation procedure for recommendations and safety precautions.
2. Weld the upper diagonal brace between the frame rail and the truck bed on each side. The ends of the diagonal brace should be 20" above the truck bed and a minimum of 20" from the end of the truck bed.

4.6 Battery Connection

There are three methods connect the battery. Only one of the following methods is required to complete the wiring installation.

- Direct Battery Connection (not recommended)
- Cut-Off Solenoid Connection
- Cut-Off Switch Connection

WARNING



PERSONAL INJURY HAZARD

Never secure the power cable to anything which allows it to contact sharp edges, other wiring, the fuel tank, fuel lines, brake lines, air lines, exhaust system, or any other object that could cause the power cable to wear or be damaged. A cut battery cable can cause sparks resulting in loss of vehicle control, serious injury, or even death.

Anthony Liftgates strongly recommends the installation of a power cut-off solenoid or cab cut-off switch. Not cutting off power to the liftgate when unattended can result in serious injury or death to unauthorized users or others near the liftgate.

The liftgate must be properly grounded. A ground wire, the same gauge or larger as the liftgate power cable, must be connected from the negative post of the battery or batteries to the truck's frame. Some trucks may have a properly sized ground wire from the battery to the frame and would require no change. If, however, there is no ground wire or it is undersize, add the correctly sized ground wire.

If this Warning is not followed, damage to the truck chassis may occur. Improper grounding can cause the electrical current to travel through brake lines, steel braided power steering hoses, or other chassis wiring causing failure to these components! Failure of these components could result in loss of vehicle control.

4.6.1 Direct Battery Connection (not recommended)

NOTICE

Using the standard wiring hookup is not recommended because it does not cut off power to the liftgate when the truck is left unattended. A cut-off switch or cut-off solenoid will disable the use of the liftgate when the truck is not in use.

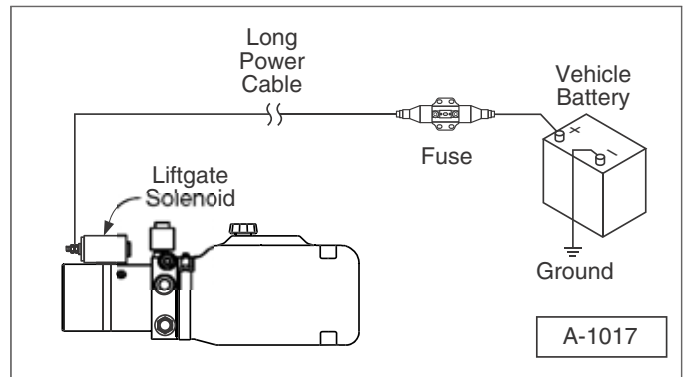

Direct battery connection (not recommended).

- Position the fuse assembly near the battery so the short cable end will reach the positive terminal.
- Run the long end of the power cable from the fuse to the motor solenoid. If the power cable is longer than required, cut it to the desired length and attach a cable lug according to instructions listed below.

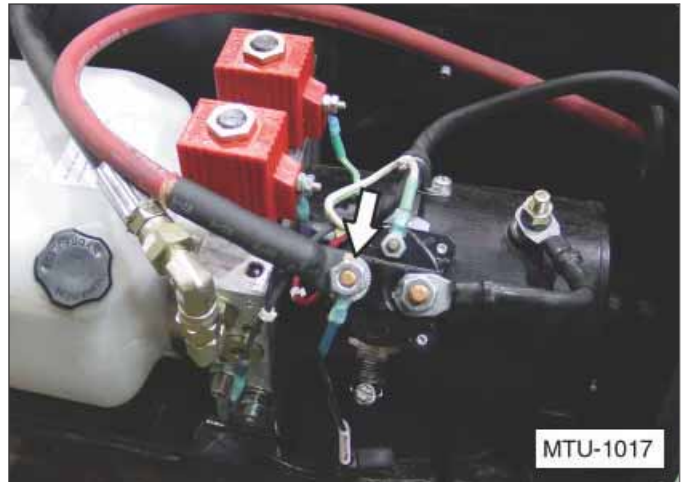

Connect power cable to motor solenoid.

- Connect the power cable to the motor solenoid. Make sure the power cable is connected to the correct motor solenoid post (one not connected to the motor housing with a metal strap or wire cable).
- Connect the short end of the power cable to the positive post of the battery.
- The power unit should now be operational.
- Coat all terminal ends, studs, and nuts with a Teflon lubricant, grease, or other electrical connection sealant to prevent corrosion.

Note: Do not apply undercoating to power cable or fuse holder! The power cable should be clean near the fuse holder to ensure easy removal of the rubber boot seals if fuse needs to be replaced. For fuse replacement, see the instructions in the Maintenance section of this manual.

4.6.2 Cut-Off Solenoid Connection

The installation of a cut-off solenoid is a recommended option, by Anthony Liftgates, for all 12 Volt electric liftgates. Installing a cut-off solenoid will help to prevent accidental or unauthorized use of the liftgate.

The optional A-133036 Cut-Off Solenoid Kit can be used in any truck, but is essential for tilt cab applications because it requires only a light weight wire running to the cab—not a large cable as required by the cut-off switch.

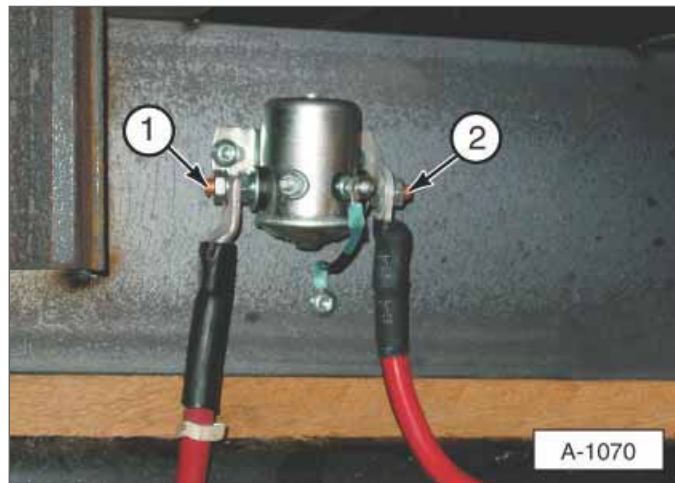

Cut-off solenoid installed between battery and fuse assembly. (1) Short cable, part of solenoid kit. (2) Short end of power cable leading to fuse.

Follow the installation directions on the Installation Instruction sheet that comes with the kit.

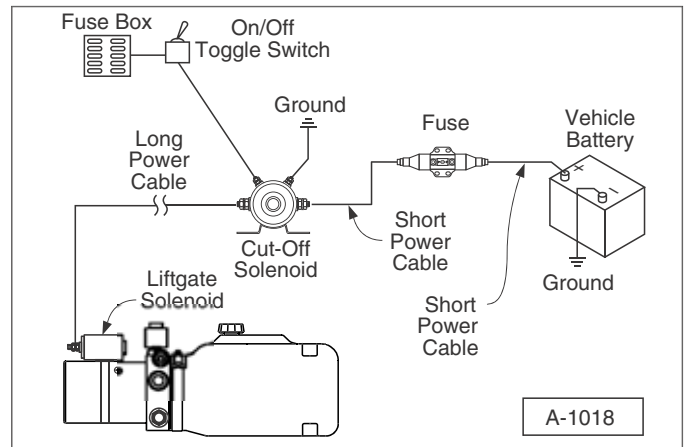

Wiring diagram with cut-off solenoid.

4.6.3 Cut-Off Switch Connection

The installation of a cut-off switch is also a recommended option, by Anthony Liftgates, for all 12 Volt electric liftgates. Installing a cut-off switch will help to prevent accidental or unauthorized use of the liftgate.

Follow the installation directions on the Installation Instruction sheet that comes with the kit.



Cut-off switch mounted in cab of truck.

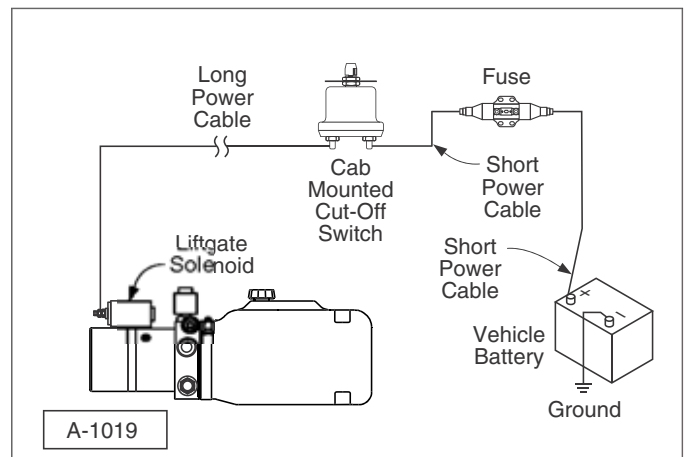

Wiring diagram with cab cut-off switch.

4.7 Cable Lug Installation

- a. Strip insulation one inch back from the end of the cable to expose the copper wire.

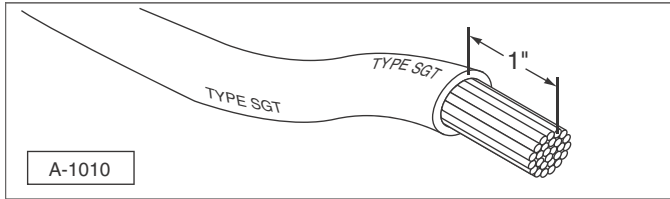

- b. Position the cable lug on the exposed wire, as shown. Crimp the cable lug using a cable crimping tool (hydraulic or manual).

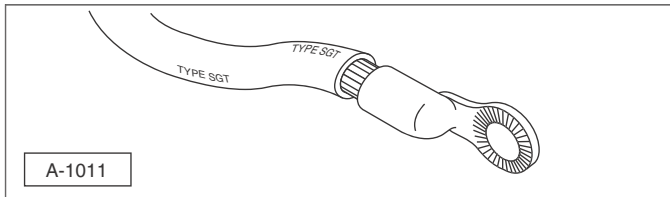

NOTICE

Proper wire connections are crucial to the life of the liftgate's power unit. DO NOT smash the cable lug with a hammer to secure it to the cable. Poor connections can result in low voltage, and any attempt to operate below the minimum required voltage could cause system failure.

- c. Use heat shrink tube to insulate the new connection. Heat the shrink tubing using a heat gun or propane torch until it shrinks around the cable insulation and cable lug, leaving only the mounting hole exposed. Do not overheat the heat shrink tubing.

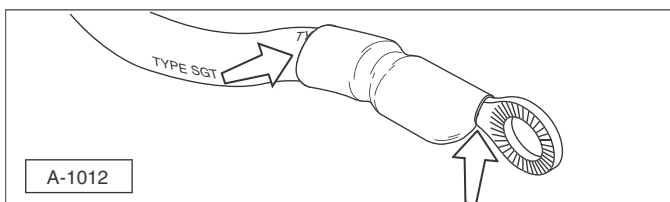

4.8 Final Inspection Checklist

WARNING



PERSONAL INJURY HAZARD

Do not use the liftgate if any of the items in the Final Inspection Checklist are not checked and verified. Serious personal injury or death may result. If you have any questions, contact your nearest Anthony distributor, or the Anthony Liftgates main office.

- Check all welds to make sure they are done properly.
- Make sure the power unit reservoir is filled.

Use only Dexron VI, Dexron III, or Hyken Glacial Blue hydraulic fluid. For cold weather operation, we recommend Hyken Glacial Blue.
- Make sure the cover over the power unit enclosure is reinstalled. Make sure the cover on the battery box is closed.
- Operate the liftgate through its entire operational cycle (up, down, open, and close) several times. Make sure the liftgate operates evenly, freely, and smoothly throughout the entire operating range and that there is no unusual noise or vibration while operating the liftgate.
- Make sure all decals are in place and legible.
- Make sure the truck meets all Local, State, and Federal regulations; including, but not limited to those required for bumpers, lighting, and reflectors.
- Do not apply a frame undercoating (sealant) to power cable or fuse holder! The power cable should be clean near the fuse holder to ensure easy removal of the rubber boot seals if fuse needs to be replaced. For fuse replacement, see the instructions in the Maintenance section of this manual.
- Put the Installation and Operation manual in the glove compartment of the vehicle.

5. Decals

SAFETY INSTRUCTIONS



To prevent possible injuries due to improper operation, make sure all decals are attached to the liftgate and/or truck and are legible at all times.

Safety decals provide a vital role in helping to reduce injuries and/or possibly even death. To ensure the greatest level of safety, all decals must be in place and legible at all times. Remember, it is the users responsibility to maintain these decals.

English decals are provided on each liftgate. Spanish versions are available upon request from Anthony Liftgates, Inc.

For replacement decals contact:

Anthony Liftgates, Inc.
1037 West Howard Street
Pontiac, Illinois 61764
Phone (815) 842-3383
Fax (815) 844-3612

Web: www.anthonyliftgates.com

Email: Sales@anthonyliftgates.com

1. A-131113

**LA-86 LIFTGATE
OPERATING INSTRUCTIONS**

1 TURN CAB CUT-OFF SWITCH TO ON POSITION.

2 REMOVE COTTER FROM RIGHT LATCH PIN

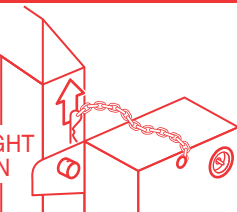

3 PULL CABLE ON PLATFORM TO DISENGAGE LATCH PINS.

4 PRESS SWITCH: UP TO RAISE, DOWN TO LOWER.

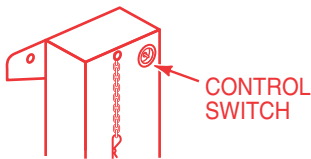

5 TO CLOSE UNIT:
 -RAISE PLATFORM TO BEDLEVEL.
 -LIFT PLATFORM MANUALLY UNTIL LATCH PINS ARE ENGAGED IN CATCHES.
 -INSERT COTTER IN RIGHT LATCH PIN.

6 TURN CAB CUT-OFF SWITCH TO OFF POSITION.

A-131113

2. A-131058-C

View fuse through clear fuse holder, if blown, replace as follows:

Liftgate fuse changing procedure.

Warning! To avoid injury, disconnect the liftgates power from the battery(ies) before replacing the fuse, or before disassembling the fuse holder. Do not ignore this warning or an "arc" can occur and personal injury or property damage could result.

1. Pull back rubber boots from fuse holder.
2. Unscrew the fuse holder ends from the fuse holder body and pull apart.
3. Slide the fuse holder body one direction (left or right) to expose the blown fuse.
4. Loosen screw from each end of fuse, remove and replace fuse. Tighten screws.
5. Re-assemble in reverse order. Be sure the rubber boots seal around the fuse holder and cable.
6. Re-connect power after you are certain liftgate area is clear.

Note: Check for spare fuse in liftgate manual packet. If fuses continue to blow, contact a qualified mechanic to remedy the problem.

Observe el fusible a través del portafusible transparente; si está quemado, cámbielo de la manera siguiente:

Procedimiento para cambiar el fusible de la compuerta elevadora.

¡Advertencia! Para evitar lesiones, desconecte la alimentación de la(s) batería(s) de la compuerta elevadora antes de cambiar el fusible, o antes de desarmar el portafusible. No pase por alto esta advertencia ya que puede formarse un arco eléctrico y causar lesiones corporales o daño al equipo.

1. Tire de las fundas de caucho del portafusible hacia atrás.
2. Destornille los extremos del portafusible del cuerpo del mismo y sepárelo.
3. Deslice el cuerpo del portafusible en un sentido (a la izquierda o derecha) para dejar al descubierto el fusible quemado.
4. Afloje el tornillo de cada extremo del fusible, retire y reemplace el fusible. Apriete los tornillos.
5. Vuelva a armar en orden inverso. Verifique que las fundas de caucho sellen bien alrededor del portafusible y cable.
6. Conecte la alimentación después de comprobar que el área de la compuerta elevadora está despejada.

Nota: Busque el fusible de repuesto en el paquete del manual de la compuerta elevadora. Si los fusibles siguen quemándose, comuníquese con un mecánico competente para que solucione el problem.

A-131058-C

DANGER	
MAXIMUM CAPACITY Do Not Exceed	
<h1 style="margin: 0;">2000 lb.</h1>	
<p>Before using the liftgate:</p> <div style="display: flex; align-items: flex-start;"> <p>READ THE MANUAL — To prevent serious injury and/or death you must read, understand, and follow all operating instructions on truck and in manual. Do not allow untrained operators or children to use liftgate. For the most current manual, call or go to www.anthonyliftgates.com.</p> </div>	<div style="display: flex; align-items: center;"> <p>PINCH POINTS — Keep all body parts away from potential pinch points.</p> </div>
<div style="display: flex; align-items: center;"> <p>STAND CLEAR</p> </div> <p>To prevent crushing, the operator or any bystanders should never stand in or move through the area in which the liftgate may operate, or into the area which an upset load might fall.</p>	<div style="display: flex; align-items: center;"> <p>DO NOT MOVE TRUCK — Never move truck when liftgate is open as this can cause personal injury and or equipment damage.</p> </div>
<div style="display: flex; align-items: center;"> <p>APPLY PARKING BRAKE — To prevent unwanted truck movement, park on flat ground and apply parking brake before using liftgate.</p> </div>	<div style="display: flex; align-items: center;"> <p>NO FORKLIFT — To prevent liftgate damage or possible personal injury never drive forklift onto platform.</p> </div>
<div style="display: flex; align-items: center;"> <p>DO NOT OVERLOAD — Do not exceed maximum capacity for loading or unloading.</p> </div>	<div style="display: flex; align-items: center;"> <p>INTENDED USE ONLY — This liftgate is intended for loading and unloading of cargo only. Do not use this liftgate for any other purpose.</p> </div>
<div style="display: flex; align-items: center;"> <p>STABILIZE LOAD — Do raise or lower potentially unstable loads. Place each load within edges of platform. Center load, side-to-side, on platform. Keep load as close as possible to truck sill.</p> </div>	<div style="display: flex; align-items: center;"> <p>INSPECT BEFORE USE — To prevent personal injury, always inspect this liftgate before use. If there are signs of improper maintenance, damage to vital parts, or signs of abnormal wear, do not use the lift.</p> </div>
<div style="display: flex; align-items: center;"> <p>FALLING HAZARD — If it is necessary to stand on the liftgate during operation, make sure you are firmly standing on platform and within the edges of platform.</p> </div>	<div style="display: flex; align-items: center;"> <p>QUALIFIED REPAIR PERSONNEL Do not attempt to repair lift unless you are specifically trained.</p> </div>
<div style="display: flex; align-items: center;"> <p>SLIPPERY SURFACE — To prevent falling use caution when loading or unloading if platform surface is wet.</p> </div>	<div style="display: flex; align-items: center;"> <p>UNAUTHORIZED USE — To prevent unauthorized use of the liftgate, if equipped with power cut-off switch, turn OFF when not in use.</p> </div>
NOTICE	
<div style="display: flex; align-items: center;"> <p>To prevent electrical overload damage, this liftgate is protected with a fuse located near the power supply. If the liftgate does not operate, first check the fuse.</p> </div>	
NOTE	
<div style="display: flex; align-items: center;"> <p>DISENGAGE To prevent damage, disengage latch before attempting to use the liftgate.</p> </div>	<div style="display: flex; align-items: center;"> <p>ENGAGE To prevent unwanted opening of liftgate, engage or secure latch after using lift.</p> </div>
<div style="display: flex; align-items: center;"> <p>Anthony Liftgates are made in the USA. 800-482-0003 — www.anthonyliftgates.com</p> </div>	

A-131114

6. Operation Section

6.1 General Operating Safety

The following is a list of Do's and Don'ts for the operation of the liftgate.

✓ Do's

- ✓ Read and follow warning decals, operating decals, and owners manual(s).
- ✓ Keep all decals in place and legible and retain the owners manual(s) in the vehicle or all Warranties are void.
- ✓ Make sure the vehicle is properly and securely braked before using the liftgate.
- ✓ Keep yourself clear of all moving parts.
- ✓ Make sure the area where the platform will be functioning (up, down, open, and close) is free of obstructions and people before operating the liftgate.
- ✓ Make sure the platform area, including the area in which loads may fall from the platform, is clear before, during, and at all times while operating the liftgate.
- ✓ Always place the load as close to the center of the platform as possible. Also, position the load as close to the center of the truck's rear sill as possible.
- ✓ Make sure the cylinders and platform's frame mechanism moves smoothly with no unusual noise or vibration.
- ✓ Only operate the liftgate with the Raise/Lower control mounted on the liftgate.
- ✓ Follow a complete, thorough lubrication and maintenance schedule as directed by this manual.
- ✓ Check the fluid level in the power unit hydraulic tank monthly. Fill the tank, as required, with Dexron VI, Dexron III, or Hyken Glacial Blue hydraulic fluid. Change the oil if it is dirty or contaminated. For cold weather operation, we recommend Hyken Glacial Blue.
- ✓ Visually inspect your liftgate frequently and keep it properly adjusted.
- ✓ Repair any damage to the liftgate to prevent accidents.
- ✓ Place the liftgate into the transport/storage position with the platform latched when the liftgate is not in use.

✗ Don'ts

- ✗ Do not overload the platform. The maximum rated capacity is based on an evenly distributed load on the platform's flat surface.
- ✗ Do not ride on the liftgate. Always stand clear of the liftgate when it is operating.
- ✗ Do not allow children to play around or operate the liftgate.
- ✗ Do not allow your liftgate to be used by persons not familiar with its operation.
- ✗ Do not crash your liftgate into loading docks or other objects which can inflict serious damage to the liftgate.
- ✗ Do not use your liftgate if it shows signs of abuse or fails to operate freely and smoothly.
- ✗ Do not allow the motor/pump to run after the liftgate is fully raised and has stopped moving.
- ✗ Do not use brake fluid in the hydraulic reservoir.
- ✗ Do not bounce the platform by pushing and releasing the control button/switch abruptly.
- ✗ Do not use the liftgate for anything other than its intended use of loading and unloading cargo.
- ✗ Do not operate lift trucks on or over any part of the platform.
- ✗ Do not stand under or place any object under the liftgate work area.
- ✗ Do not drive the truck unless the liftgate is in the transport/stored position and the platform latches are secured.

6.2 Operating Instructions

6.2.1 Opening and Closing the Liftgate

WARNING



CRUSH HAZARD - STAY CLEAR

Do not stand in the platform's work area while operating the liftgate. Serious injury or death could result if the load shifts or is unstable on the platform.

1. Turn cab cut-off switch to ON position.
2. Remove the hair pin clip from the curbside latch pin.

WARNING



CRUSH HAZARD OPENING PLATFORM

Once the platform latch mechanism is released, the platform is free to fall open. Do not release the platform until it is supported, by hand, to prevent it from falling. The weight of the platform can cause serious injury if allowed to open (fall) freely.

3. Place your hand toward the top of the platform and pull the latch pin release cable. The platform is now free to open (fall). Although the platform opening and closing is spring assisted there is some weight associated with the open and closing process. Be prepared to lower the platform, by hand, in a controlled manner.
4. Lower the platform, by hand, to the horizontal position.
5. Press the toggle switch down to lower the platform to the ground.
6. Load the cargo onto the platform. If necessary, open the cart stops by kicking the release mechanism with your foot to prevent the cargo from sliding off the ramp.
7. Press the toggle switch up to raise platform.
8. From the ground, to place the liftgate into its transport or storage position after use, raise the platform using the control switch, push the platform upward by hand, until the latch pins are engaged, and place the hair pin clip into the curbside latch pin.
9. Turn the cab cut-off switch to the OFF position.

LA-86 LIFTGATE OPERATING INSTRUCTIONS

1 TURN CAB CUT-OFF SWITCH TO ON POSITION.

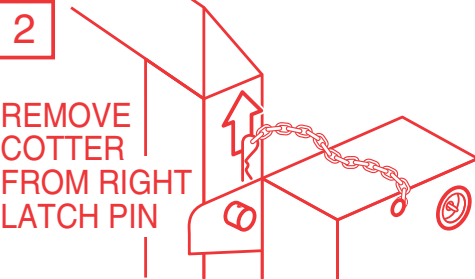

3 PULL CABLE ON PLATFORM TO DISENGAGE LATCH PINS.

4 PRESS SWITCH: UP TO RAISE, DOWN TO LOWER.

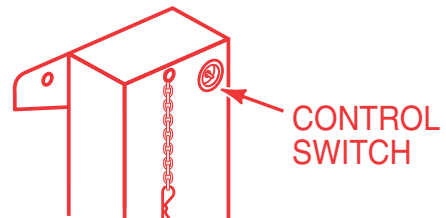

**5 TO CLOSE UNIT:
-RAISE PLATFORM TO
BEDLEVEL.
-LIFT PLATFORM MANUALLY
UNTIL LATCH PINS ARE
ENGAGED IN CATCHES.
-INSERT COTTER IN RIGHT
LATCH PIN.**

6 TURN CAB CUT-OFF SWITCH TO OFF POSITION.

A-131113

7. Maintenance Section

7.1 Preventive Maintenance

WARNING



IMPROPER MAINTENANCE

Do not attempt to maintain the liftgate without fully understanding all of our instructions and safety precautions. Do not attempt to maintain a liftgate unless you have read and understand all of the instructions and warnings in the Installation, Operation, and Maintenance manual. If any doubt or question arises about the correct or safe method of performing anything found in this or other Anthony Liftgates' manuals, contact your Anthony Liftgates' dealer or call the Inside Sales and Service representatives at our main headquarters. Proper care is your responsibility.

To prevent serious injury or death, only qualified mechanical personnel who are aware of and/or able to understand the signs of potential problems should maintain the liftgate.

Preventive maintenance is one of the most cost-effective practices that any equipment owner can implement. Taking approximately 15 minutes of your time to inspect the liftgate can result in hundreds and even thousands of dollars in savings. These savings can come from:

- Increased operating time (no unscheduled breakdowns at someone's loading dock).
- Normal wear items will last longer because they have been properly maintained and lubricated.
- Less chance of someone becoming injured due to parts that may fail because of mistreatment or abuse.

Preventive maintenance inspections should only be completed with qualified mechanical personnel. In no way are these steps intended to encourage usage or service of the liftgate by anyone who is not qualified to do so. The overall performance of the liftgate is directly related to the skill and knowledge of the mechanic performing the inspection. If the mechanic cannot see potential problems, or is unaware of the signs of potential problems, the inspection procedure may be a costly waste of time.

7.1.1 Monthly Inspection

Preventive maintenance should be performed on a monthly schedule or any time the unit shows signs of improper/abnormal operation or abuse. Following these steps helps to ensure maximum operator safety and your overall performance satisfaction.

This inspection procedure starts at the front of the truck and works its way back to the liftgate. Make sure the vehicle is securely braked before performing any of the following steps.

1. Check the truck's battery.
 - Make sure the cells of the battery are properly filled.
 - Check the battery for cracks, leaks, or other obvious damage.
 - Make sure the battery hold-down clamp is securely tightened.
 - Make sure the liftgate power cable connection is tight.
 - Remove any corrosion, dirt, or grease from the battery terminals and/or wire connections.
 - Periodically replace the old battery. (Do not let the battery fail and then replace it).
2. Check the power cut-off switch to make sure it disables the power to the power unit when it is turned to the off position.
3. Check the power cable from the truck battery back to the liftgate power unit.
 - Make sure all connections are free of dirt and corrosion.
 - Make sure all connections are tight.
 - Make sure the entire length of the power cable is not cut or damaged.
4. Inspect the power unit enclosure for damage.
 - Remove any buildup of dirt or debris.
 - To prevent damage to wires and hoses from rubbing against the metal surface of the enclosure, make sure all the rubber grommets are installed in the access holes.
5. Add grease to the 10 grease zerks; four on each of the lift arms and two on the bottom side of the platform. Add three pumps of grease every 200 to 300 cycles of the liftgate.
6. Check the electrical and hydraulic connections inside the power unit enclosure.
 - Check all control wires for corrosion and make sure they have tight connections. When replacing connectors, use only Heat Shrink Terminals.
 - Check the electrical connections to the starter solenoids.
 - Check all hydraulic hoses and fittings for fluid leaks. Tighten the fittings to stop leaks or replace them if they are damaged.
 - Check the condition of the hydraulic hoses. Replace them if they show signs of leakage or excessive abrasion of the covering.

7. Check the fluid level in the power unit hydraulic tank. Fill the tank, as required, with Dexron VI, Dexron III, or Hyken Glacial Blue hydraulic fluid. For cold weather operation, we recommend Hyken Glacial Blue.

NOTICE

Use only Dexron VI, Dexron III, or Hyken Glacial Blue hydraulic fluid. For cold weather operation, we recommend Hyken Glacial Blue.

If an emergency situation occurs, any anti-wear hydraulic fluid can be used, but the system should be flushed and the fluid changed as soon as reasonably possible. Hydraulic fluids should not be mixed due to possible compatibility problems.

The recommended fluids are compatible and may be mixed, however, the cold weather operating characteristics of Hyken Glacial Blue will be adversely affected.

8. Inspect the hoses and control wires.
- Check for signs of leaks or chaffing on the outside covering of the hoses and wiring.
 - Make sure the wires are securely fastened to the truck body and not hanging loose where they could be damaged.
 - Remove any build-up of dirt and debris from the hoses and wires.
9. Make sure the liftgate is operating properly through the complete opening and closing cycle. Before operating the liftgate, make sure the area is free of all obstacles, obstructions, or people. Also, if the liftgate is equipped with a power cut-off switch, turn the switch to ON.
- Check for any clearly visible damage that would prevent the liftgate from operating properly.
 - Make sure both the streetside and curbside latches release.
 - Check the control switches for corrosion, dirt build-up, or damage.
 - Check for unusual noises or vibration as the liftgate operates.
 - Check for any mechanical interference in the lift arms as the platform opens.
 - Make sure the liftgate operates freely and smoothly throughout its entire range of movement (up, down, open, and close).
 - Make sure the platform is level when raised to bed height.

10. Inspect the liftgate.
- Inspect the liftgate for damage (bent platform members or lift arms, cracked welds, etc).
 - Check all the fasteners on pins, brackets, etc. to make sure those parts are securely held in place.
 - Check the platform connection points. Make sure they are in good shape and the ends are connected properly.
 - Inspect the cart stops and make sure they work properly.
 - Grease the platform hinge points.
11. Inspect the lift arms.
- Clean any build-up of grime or dirt off of the lift arms (power wash if necessary).
 - Check both mechanical and hydraulic connections to the cylinders.
 - Check for any excessive wear or gouging of lift arms.
 - To decrease the effects of road salt, road grime, and dirt, you can clean the lift arms with a power washer.
12. Check for hydraulic fluid leaks on the two cylinders, along the path of the hydraulic hoses, and in the power unit enclosure. Replace the hoses if they show signs of excessive abrasion or leakage. Tighten any hydraulic fittings showing signs of leakage and replace any hydraulic fittings which are damaged.
13. Examine all warning, capacity, and operational decals. If they are not readable they should be replaced. New replacement decals can be obtained from Anthony Liftgates, Inc.
14. Place the liftgate in the stored position and turn OFF the power cut-off switch after each use and/or inspection.
15. If you find anything that shows signs of excessive wear or damage, replace that part and any mating parts that may also be damaged.

If you have any doubts or questions about maintaining the liftgate, call us.

7.1.2 Semi-Annual Inspection

In addition to the items requiring monthly inspection, also inspect the condition of the hydraulic fluid.

If the oil in the hydraulic tank is dirty, drain the oil and flush the entire system. Refill the system with the recommended oil outlined in Step 7 of the "Monthly Inspection" section.

7.2 Maintenance and Troubleshooting Procedures

7.2.1 Replacing the Fuse

1. Pull back the rubber boots from the fuse holder.

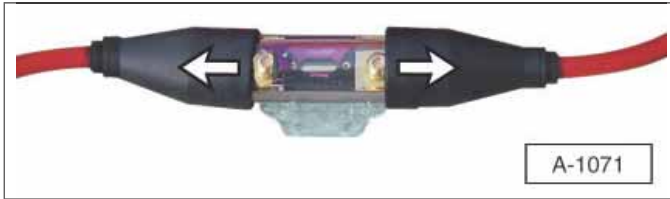

2. Unscrew the fuse holder ends from the fuse holder body and pull it apart.

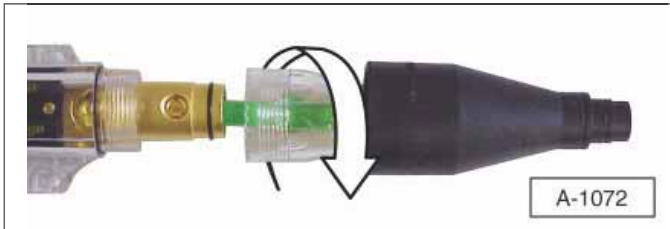

3. Slide the fuse holder body one direction (left or right) to expose the blown fuse.
4. Loosen the screws from each end of the fuse, remove, and replace the fuse. Retighten the screws.
5. Reassemble the fuse in reverse order. Be sure the rubber boots are sealed around the fuse holder and cable.
6. Reconnect the power after you are certain the liftgate area is clear.

7.2.2 Checking the Lowering Valve Cartridge and Coil

1. Place the platform on the ground in the open position.
2. Place a steel screwdriver over the top of the valve cartridge coil.

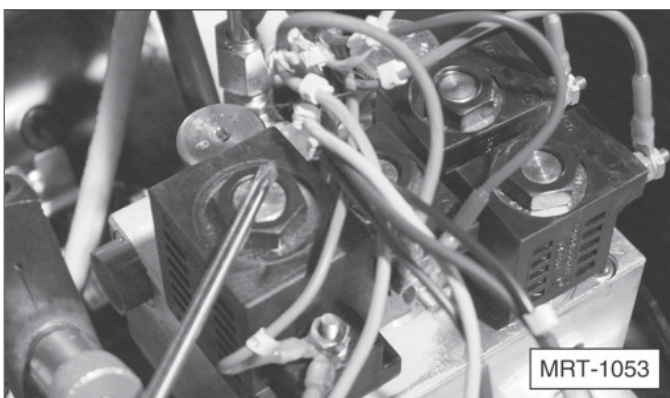

3. Momentarily activate the control switch in the DOWN position. The screwdriver should be attracted to the magnetic field created by the coil.
4. If there is no magnetism, determine if there is power from the control switch to the coil. If there is no power, determine if the switch is bad or if the problem is in the wire from the switch to the coil. If there is power to the coil, but it has no magnetism, then the coil is bad and should be replaced. If the coil is good, check the lowering valve cartridge for proper operation.
5. Remove the coil from the lowering valve cartridge assembly.
6. Remove the lowering valve cartridge from the pump body.
7. Clean the lowering valve cartridge and blow it dry with compressed air (not greater than 30 psi). Also, blow out the pump body.
8. Use a small screwdriver and carefully press on the poppet inside the lowering valve cartridge. The poppet is spring loaded and should move when it is pressed. If the poppet does not move, then the lowering valve cartridge should be replaced.

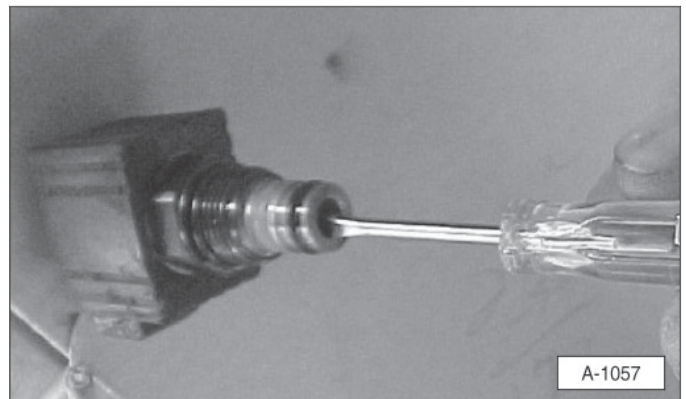

7.2.3 Checking Motor Start Solenoid and Power Cut-off Solenoid

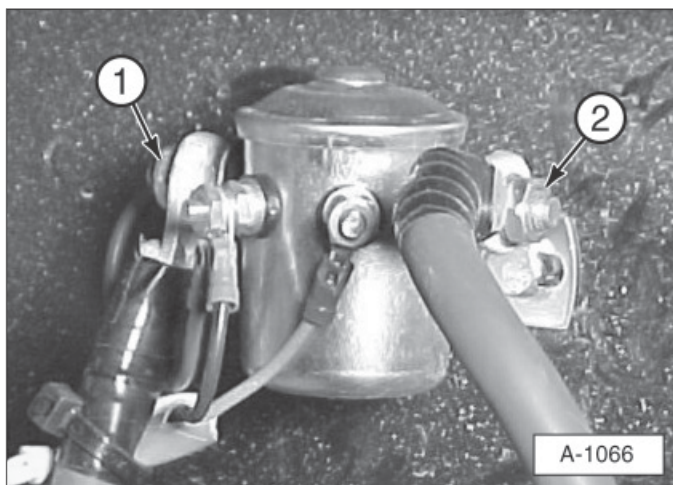
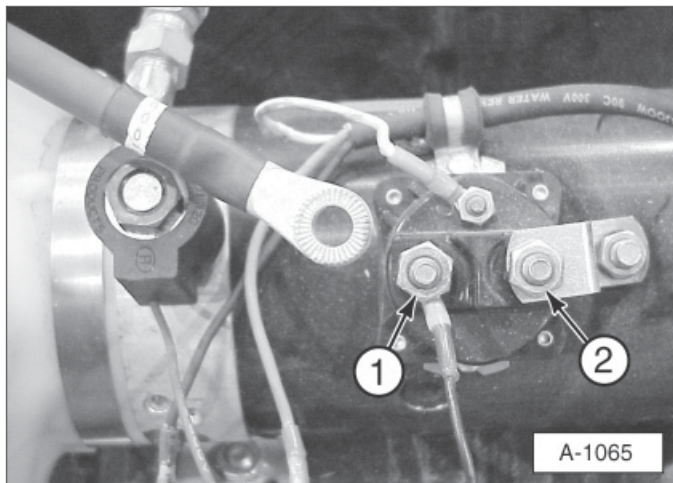

Both the motor start solenoid and power cut-off solenoid can be checked by bypassing the solenoid itself.

1. Use jumper cables for this test.
2. Connect one jumper cable to the battery side (2) of the solenoid. Connect the other cable to the motor side (1) of the solenoid.
3. If the liftgate is activated, the solenoid is bad and should be replaced.

7.2.4 Inspecting the Cylinder Piston Rod Seals

Inspect the cylinder piston rod seals for drifting, caused by seal leakage.

1. Remove the breather hose, if equipped.
2. Raise the platform all the way up and hold the switch in the "ON" position while checking for oil coming out of the breather port to the cylinder.
3. If a continuous flow of oil comes out of this port, while the platform is all the way up and the switch is held "ON", then the piston seals are leaking and the cylinder should be replaced.

7.2.5 Checking the Relief Valve

To check the pressure setting:

1. Place the platform on the ground and remove the pressure hose from the port on the pump.



2. Install a tee (customer supplied) into the port.
3. Connect a pressure gauge to the tee (with a capacity rating of 4000 psi or above) and reconnect the hydraulic hose. The pressure gauge should be connected to a hose that allows the mechanic to read the gauge without being near the platform.
4. Raise the platform until the cylinder stops traveling, then continue holding the control switch in the RAISE position until a relief pressure reading can be taken from the test gauge.
5. If the pressure does not reach 2300 psi, replace the pump.

7.2.6 Flow Control Valve

The flow control valve is designed to keep the liftgate from lowering too rapidly under a heavier load.

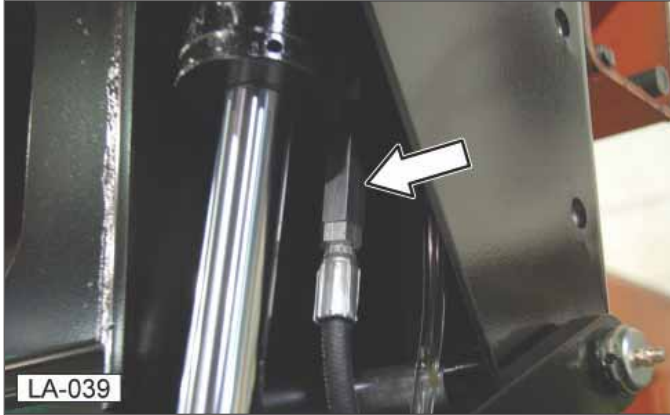

WARNING



CRUSH HAZARD

Do not operate the liftgate without the flow control valve because the platform may lower too rapidly under heavier loads.

Serious injury or death could result if this action is not followed.

1. Test the flow control valve by comparing the lowering speed with and without a load.
2. If the lowering speed varies by more than 10 percent, replace the flow control valve and run the test again.

7.3 Troubleshooting Chart

Problem	Possible Causes	Possible Solution
Platform will not close, motor does not run when control switch is activated.	Dead or low battery.	Make sure battery is fully charged. Check for loose or corroded battery connections. Replace or recharge battery.
	Corroded or loose wire connections.	Check all wire connections on power unit for corrosion or looseness. Replace defective terminals with "heat shrink" factory type terminals. Check main power cable from batteries, to fuse, to cut-off switch, to power unit.
	Blown fuse.	Replace fuse. See "7.2.1 Replacing the Fuse" on page 28.
	Blown fuse in power unit box. (Located in power unit box.) (10 Amp fuse)	Replace, if fuse is blown. If problem continues, check for shorts in the electrical system.
	Defective control switch.	Check switch, replace if defective.
	Motor start solenoid.	Check coil. Replace if defective. See "7.2.3 Checking Motor Start Solenoid and Power Cut-off Solenoid" on page 29.
	Defective motor.	If the motor is determined to be bad, it should be replaced. Bad motors are often caused by loose connections, corrosion, a poor ground, or low voltage (which is a result of weak batteries).
	If the motor does not operate in freezing conditions, make sure the motor housing does not contain water.	
Motor runs, but platform will not lower to the ground.	Structural damage.	Fix damage. Replace worn parts.
	Defective control switch.	Check the control switch. Replace the switch if it is not operating correctly.
	Defective lowering valve coil.	Check the coil using the procedure in "7.2.2 Checking the Lowering Valve Cartridge and Coil" on page 28.
	Defective lowering valve cartridge.	Check, remove, and clean valve cartridge using the procedure in "7.2.2 Checking the Lowering Valve Cartridge and Coil" on page 28.
	Defective flow control valve.	Replace the flow control valve. See "7.2.6 Flow Control Valve" on page 30.
	Low voltage.	Recharge battery (if less than 9 Volts).
	Defective hydraulic pump and motor.	Replace power unit.
Foaming oil.	Air in the hydraulic hose(s).	Check oil level in reservoir. See "7.1.1 Monthly Inspection" on page 26.
	Broken or loose fluid return tube.	Remove the oil reservoir and make sure the return tube is below the oil level. If the tube has turned or fallen out, reinstall it into the pump housing. Use a center punch to "stake" the tube into position.
	Low hydraulic oil level.	Fill hydraulic reservoir (with the platform completely lowered to the ground). See "7.1.1 Monthly Inspection" on page 26.
Platform raises partially and stops.	Load capacity has been exceeded.	Verify load capacity and adjust load weight.
	Structural damage.	Replace damaged parts.
	Low Voltage.	Recharge battery (if less than 9 Volts).
	Low pressure.	Refill reservoir. Check pump and motor.
Platform will not open.	Platform is still latched.	Release the latches.

Problem	Possible Causes	Possible Solution
Motor runs, but platform will not raise, will not raise rated capacity, or raises but drifts down when control switch is released.	Load capacity has been exceeded.	Verify load capacity and adjust load weight.
	Structural damage.	Replace damaged parts.
	Low fluid level.	Fill reservoir (with the platform completely lowered to the ground). See "7.1.1 Monthly Inspection" on page 26.
	Low Voltage.	Inspect the battery connection terminals and check the battery's Voltage (9 Volts minimum).
	Dirty or defective lowering valve.	Coil or cartridge may need cleaning or replacement. See "7.2.2 Checking the Lowering Valve Cartridge and Coil" on page 28.
	Bad piston seals.	See "7.2.4 Inspecting the Cylinder Piston Rod Seals" on page 29.
	Hydraulic pump is worn.	Replace hydraulic pump.
	Air in hydraulic lines.	Fill reservoir to within 1/2" of full with platform on ground. See "7.1.1 Monthly Inspection" on page 26.
	Cylinder piston seals blown, allowing fluid to leak past piston when trying to raise platform.	Remove breather hose from end of cylinder. Activate power unit to raise position, if hydraulic fluid pumps out of breather port, replace cylinder - DO NOT repack or dismantle). See "7.2.4 Inspecting the Cylinder Piston Rod Seals" on page 29.
	Lowering valve stuck partially or fully open.	With platform on ground, remove lowering valve and inspect. Clean if dirty. Replace if plunger not freely moveable. See "7.2.2 Checking the Lowering Valve Cartridge and Coil" on page 28.
Platform lowers slower than normal.	Cold weather conditions.	Use Hyken Glacial Blue hydraulic fluid for cold weather operation.
	Improper oil in hydraulic reservoir.	Use only Dexron VI, Dexron III, or Hyken Glacial Blue hydraulic fluid. See "7.1.1 Monthly Inspection" on page 26.
	Damaged or kinked hydraulic hose.	Repair or replace hose.
	Cylinder rod is scored, pitted, or bent.	Replace cylinder.
	Defective flow control valve.	Replace the flow control valve. See "7.2.6 Flow Control Valve" on page 30.
Lift arms are dirty, damaged, or need grease.	Clean lift arms and grease. Replace lift arms if they are bent or damaged.	

Note: For the most up-to-date troubleshooting tips, go to www.anthonyliftgates.com and click on "Customer Service", then the "Troubleshooting" tab on the drop-down menu.

8. Limited Warranty

8.1 Limited Warranty

2 yrs Mechanical + 2 yrs Electric/Hydraulic

Thank you for purchasing an Anthony liftgate. We strive to produce the most trouble-free and reliable liftgates in the market. We believe you will experience years of reliable operation and minimum downtime interruptions. To further ensure your confidence in Anthony Liftgates, this warranty will cover your unit for 2 years or 5,500 cycles (whichever occurs first) on mechanical/structure, electrical, and hydraulic operating parts. This warranty is extended to the original purchaser (user only) and is not transferable. The warranty term begins from the date of shipment from our factory or warehouse.

Anthony Liftgates Inc. will cover all failed components during the warranty period. Labor will be provided under our Flat Rate Warranty Schedule, in effect at the time of the part failure, and includes diagnosis time. Contact Anthony Liftgates for current reimbursement amounts. For repairs NOT listed on the Flat Rate Warranty Schedule, contact the Anthony Warranty Department for approved reimbursement, prior to performing repairs. Anthony Liftgates Inc. reserves the right to determine whether a component is defective or has failed. This warranty applies to Anthony liftgates installed, operated, and maintained in accordance with Anthony Liftgates Inc. installation, operation, and maintenance manuals, videos, etc.

Certain Anthony Liftgate models have published Lifetime Warranties on listed components, as published in current literature. This additional coverage will be detailed on the published operation components, providing the unit has been operated and maintained within the intended usage.

Anthony Liftgates, Inc. will process all claims and determine their eligibility for authorization upon the receipt of the failed part, the identification of the claimant, and the liftgate serial number. All parts must be returned freight prepaid and following the instructions given by the Anthony Warranty Department. Freight collect shipments will not be accepted.

PLEASE NOTE THAT NO CLAIMS WILL BE PROCESSED WITHOUT THE PART, THE CLAIMANT'S INFORMATION, AND THE LIFTGATE SERIAL NUMBER.

Claims not submitted within 30 days of repair date will be denied.

NOTE: ALL CLAIMS MUST BE COMPLETED ON THE ANTHONY LIFTGATES INC. WARRANTY CLAIM FORM.

This form provides all the necessary information.

Upon approval of the claim, Anthony Liftgates will, at the direction of the claimant, return a replacement part and labor allowance, or a parts credit based on current distributor net pricing, and the appropriate flat rate labor allowance.

Anthony Liftgates, Inc. is not responsible or liable for loss of time, cost, labor, material, profits, direct or indirect damages caused by failed components, whether due to rights arising under purchase, order, contract of sale or independently thereof, and whether or not such claim is based on contract, tort, or warranty. The sale of products of Anthony Liftgates, Inc. under any other warranty or guarantee express or implied is not authorized. This warranty does not cover misuse, abuse, damage, or product finish, normal wear, maintenance adjustments, careless or negligence of use or maintenance. Modifications to our product are not covered unless prior authorized by Anthony Liftgates.

Purchased Parts warranty is 1 year from date of purchase and covers replacement of part only.

If you require assistance or have questions, please contact Anthony Liftgates Inc. at 815-842-3383.

NOTE: Most (not all) Anthony liftgate models incorporate our Service-Free feature. Service-Free refers to the fact that these models require no routine or scheduled lubrication of the major pivot points that contain our service-free bushings. Normal repair and maintenance of your liftgate, per our instruction, is necessary for ALL Anthony liftgates.

Anthony Liftgates, Inc.
1037 W. Howard St. P.O. Box 615
Pontiac, IL 61764-0615

PH: 815-842-3383
FAX: 815-844-3612
E-Mail: warrantyclaims@anthonyliftgates.com

8.2 Warranty Policy and Procedure

All warranty claims must be completed on the Anthony Liftgates Warranty Claim Form utilizing the Flat Rate Warranty Schedule. See the current rates as listed for each model. Using this process will allow for quick and accurate credit payment.

Claims will not be processed without the failed part returned (pre-paid) to Anthony Liftgates, and the warranty claim form completed.

NOTE: When returning defective parts for warranty consideration, be sure to call ahead for a Return Authorization Number.

If you require further assistance or have questions, please contact the Anthony Liftgates Warranty Dept. at 815-842-3383 or email: warrantyclaims@anthonyliftgates.com.

ANTHONY
LIFTGATES, INC.®

LA-86



ANTHONY LIFTGATES, INC.
1037 W. HOWARD ST. • P.O. BOX 615
PONTIAC, IL 61764-0615
PH: 815-842-3383
FAX: 815-844-3612
TOLL FREE: 800-482-0003
WWW.ANTHONYLIFTGATES.COM