

ANTHONY

LIFTGATES, INC.®

AST - ATU - AXM



INSTALLATION, OPERATION, AND MAINTENANCE

MODELS

BED HEIGHT

AXM-1500-SF
AXM-2000-SF
AXM-2500-SF

36" - 56"

ASTL-1800-SF
ASTL-2500-SF
ATU-1800LB-SF
ATU-2500LB-SF

36" - 44"

AST-PLUS-2500-SF
ATU-GLR-25-SF
ATU-GLR-3000

38" - 56"

42" - 55"

42" - 55"

AST-1500-SF
AST-2000-SF
AST-2500-SF
AST-3000-SF
ATU-1800-SF
ATU-2500-SF
ATU-3000-SF
ATU-3500-SF

42" - 57"

ATU-1800A-SF
ATU-2500A-SF
ATU-3000A-SF

45" - 57"



QUALITY, RELIABILITY, CUSTOMER SERVICE

MADE IN THE USA 

Contents

1. General Information Section	5
1.1 Introduction	5
1.2 Installation Recommendations	5
1.3 Warranty	6
1.4 Decals	7
1.5 Ordering Parts	7
2. Safety Section	8
2.1 Safety is Your Responsibility	8
2.2 Safety Signal Words	8
2.3 Safety Rules	8
2.4 Safety Icons Nomenclature	10
2.4.1 Personal Protection/Important Information	10
2.4.2 Prohibited Actions	10
2.4.3 Hazard Avoidance	10
3. Nomenclature	11
3.1 Platform nomenclature	11
3.2 Gravity-Down Power Unit Nomenclature	12
3.3 Power-Down Power Unit Nomenclature	12
4. Installation Section	13
4.1 Tools Required	13
4.2 Bed Height Requirements	14
4.3 Unpackaging	14
4.4 Lifting Device	15
4.5 Prior to Installation	16
4.6 Installation Procedure	18
4.7 Battery Connection	27
4.7.1 Direct Battery Connection (not recommended)	27
4.7.2 Cut-Off Solenoid Connection	28
4.7.3 Cut-Off Switch Connection	28
4.8 Cable Lug Installation	29
4.9 Attaching the Power Cable to Truck Frame	29
4.9.1 Clip or Tie Wrap Installation Method	29
4.9.2 Bolt-On Method	29
4.10 Final Inspection Checklist	30
5. Optional Component Installation Procedures	31
5.1 Bolt-On Floor Extension	31
5.2 Pintle Hook Bracket Installation	33
5.2.1 Pintle Hook Bracket Maintenance	35
5.2.2 Towing Safety	35
5.3 Trailer Sub Frame Installation	36
6. Decals	37
6.1 Decal Locations	37
6.2 Decal Illustrations	38
7. Operation Section	40
7.1 General Operating Safety Instructions	40
7.2 Operating Instructions	42

- 8. Maintenance Section 43**
- 8.1 Monthly Inspection 43
- 8.2 Semi-Annual Inspection 43
- 8.3 Maintenance and Troubleshooting Procedures 44
 - 8.3.1 Platform Adjustment (adding shims) 44
 - 8.3.2 Replacing the Fuse 44
 - 8.3.3 Checking Motor Start Solenoid and Power Cut-off Solenoid. 45
 - 8.3.4 Checking the Power Cable 45
 - 8.3.5 Checking Lowering Valve Cartridge and Solenoid 45
 - 8.3.6 Solenoid Valve Screen 46
 - 8.3.7 Replacing Solenoid Valve 46
 - 8.3.8 Checking Cylinder Piston Seals (drifting - caused by seal leakage) 46
 - 8.3.9 Checking System Pressure 46
 - 8.3.10 Checking Flow Control Valve 47
 - 8.3.11 Checking Control Switch Fuse 47
- 9. Troubleshooting 48**
- 9.1 Troubleshooting Guide. 48
- 10. Inspection Record 51**
- 11. Limited Warranty 52**
- 11.1 Limited Warranty 52
- 11.2 Warranty Policy and Procedure 52

1. General Information Section

1.1 Introduction

Congratulations on selecting an Anthony Liftgates Tuckunder liftgate. Our liftgates are the finest available on the market today. To ensure your liftgate will perform to your expectations, we have provided this Installation and Operation manual as well as a separate Parts manual. These manuals are designed to provide you with the necessary instructions, safety precautions, and parts information to install, operate, and maintain the AXM, AST, and ATU Tuckunder liftgates.

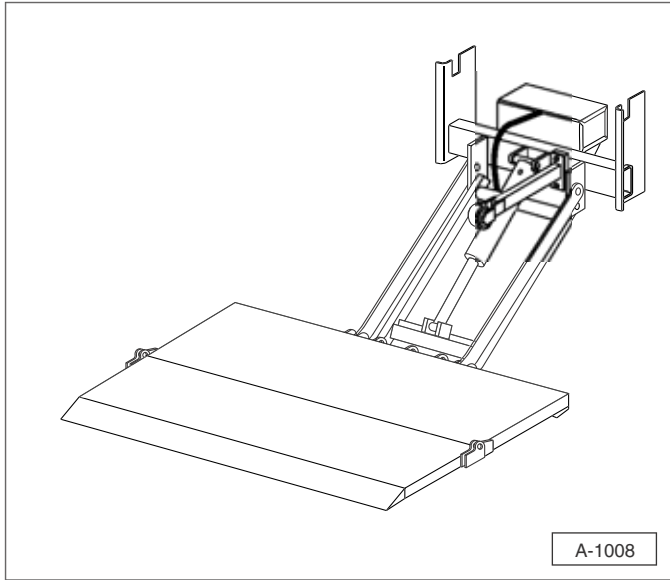

Typical Anthony Liftgates Tuckunder Liftgate.

Important Operation Notes!

A platform restraining system may be needed to retain certain types of cargo on the liftgate platform, such as a cart stop, retention ramp, fencing, straps, etc. This should be considered by the purchaser for their particular application to prevent the possibility of severe personal injury or death due to cargo shifting and/or falling from the liftgate platform.

All users of this liftgate must be at least 18 years old and have read and understood all operation instructions and safety decals before use.

⚠️ WARNING



Crush Hazard
Unsecured loads, when moved on the liftgate, can shift or fall.

To prevent personal injury or death, make sure loads are securely fastened to liftgate or restrained by cart stops, retention ramp, or fencing.

1.2 Installation Recommendations

⚠️ WARNING



The success or failure of this liftgate to properly and efficiently operate will depend on a thorough and proper installation. Failure to read, understand, and follow the installation instructions and safety recommendations in this manual before installing the liftgate can result in serious injury or death. Also read and understand the operating instructions in the Operation Section.

When installed, this liftgate must not alter nor prevent vehicle compliance to any existing state or federal standards, and especially FMVSS 105. Each chassis manufacturer's recommendations should be consulted for compliance. Also make sure the weight of the liftgate and its load will not overbalance the truck, possibly raising the front wheels off the ground.

This manual provides easy to follow instructions, along with photos and illustrations, which will help facilitate the installation process. Safety precautions have been clearly identified throughout each section of this manual and should be followed.

In addition, a complete explanation of the safety terminology and recommendations are included in "2. Safety Section" on page 8 of this manual.

Please turn to this section and read it thoroughly before proceeding to the next page.

At the bottom of each page is the Product Support phone number. If you are unclear about any of the instructions, please phone the Anthony Liftgates' Product Support department.

All Anthony Tuckunder model liftgates are factory assembled, energized, and tested to ensure the highest quality performance standards. AXM, AST, and ATU liftgates ship completely assembled for fast, clean, and easy installation.

Even though the following goes without saying, we feel compelled to state:

Anthony liftgates should only be installed by those with sufficient skills to understand the installation and operation of the liftgate, along with the equipment required to install the liftgate. The installation instructions in this manual are intended to give typical installation instructions to the installer for both the operation and what we believe to be the most desirable sequence of installation. These instructions cannot replace a qualified person, or clear thinking and the basic knowledge that must be possessed by the installer.

We urge the installer (or anyone else) to call us if they have any questions. We have qualified personnel at our Pontiac, Illinois, plant to answer any questions that you may have. A detailed discussion on the phone can be far more satisfactory than a detailed written explanation.

It has been our experience that a knowledgeable journeyman following these installation instructions and observing the operation of the liftgate will have sufficient comprehension of the liftgate to enable this person to troubleshoot and correct all normal problems that may be encountered. However, again we urge you to call us at the Pontiac, Illinois, plant if you find the liftgate is not operating properly or if you do not know how to make the necessary repair.

If you have any doubts or questions, call us at:

Anthony Liftgates, Inc.
1037 West Howard Street
Pontiac, Illinois 61764
(815) 842-3383
www.anthonyliftgates.com

1.3 Warranty

NOTICE

The liftgate must be installed according to these instructions or the warranty will be void. Unauthorized modifications of the liftgate may cause it to improperly operate or cause other unforeseen problems or dangers. If any deviation is deemed necessary, written permission must first be obtained from Anthony Liftgates.

All decals must be in place and legible or all warranties are void.

Before calling for warranty or other product information, have the serial number, model number, and lift capacity of your liftgate available. This information is stamped into the identification plate on the side of the power unit box and will help us verify your warranty information and your specific liftgate.



Serial Number Identification Plate.

Record the serial number, model number, date of installation, and load capacity for easy reference when contacting Anthony Liftgates with questions.

Serial Number Information	
Serial No.	
Model No.	
Date of Installation	
Lift Capacity	

Refer to "11. Limited Warranty" on page 52 for the complete warranty statement.

1.4 Decals

SAFETY INSTRUCTIONS



To prevent personal injury from not being aware of safety recommendations, make sure all decals are attached to the liftgate and/or truck and are legible at all times!

Safety decals provide a vital role in helping reduce injury and/or death. To ensure the greatest level of safety, all decals must be attached to the liftgate and be legible at all times. Remember, it is the users' responsibility to maintain these decals. For decal placement, or a complete part number list and illustration of the decals used on the AXM, AST, and ATU Tuckunder liftgate, refer to "6. Decals" on page 37 in this manual.

For replacement decals contact:

Anthony Liftgates, Inc.
1037 West Howard Street
Pontiac, Illinois 61764
(815) 842-3383 or 800-482-0003
www.anthonyliftgates.com

1.5 Ordering Parts

We manufacture a quality liftgate that requires very little maintenance or repair. However, should a part break, become damaged, or worn, our knowledgeable staff can make sure you receive the part(s) to put your liftgate back into operation.

Note: The liftgate's packet of information does not contain a "parts manual." The most current and up-to-date parts manuals can be obtained by accessing our website anytime.

Our website address is **www.anthonyliftgates.com**
Click on "Manual" and choose a model.

If you do not have access to the internet, or just prefer a printed copy of a manual, we can send one to you. Call or write our office listed below.

For questions or to order parts, contact:
Anthony Liftgates, Inc.
1037 West Howard Street
Pontiac, Illinois 61764
(815) 842-3383
Web: www.anthonyliftgates.com
Email: Sales@anthonyliftgates.com

2. Safety Section

2.1 Safety is Your Responsibility



It is the responsibility of the installer/operator to understand and perform proper operating procedures. Be aware of the inherent dangers in the use of this product and the tools used to install it. Read and understand all Danger, Warnings, Cautions, and Important Notices in this manual and on the liftgate or truck.

2.2 Safety Signal Words



This is the safety alert symbol. It is used to alert you to potential personal injury hazards. Obey all safety messages that follow this symbol to avoid possible injury or death.

This manual contains DANGERS, SAFETY INSTRUCTIONS, CAUTIONS, IMPORTANT NOTICES, and NOTES which must be followed to prevent the possibility of improper service, damage to the equipment, personal injury, or death. The following key words call the readers' attention to potential hazards.

Hazards are identified by the "Safety Alert Symbol" and followed by a signal word such as "DANGER", "WARNING", or "CAUTION".

DANGER

Indicates an imminently hazardous situation which, if not avoided, will result in death or serious injury. This signal word is limited to the most extreme situations.

WARNING

Indicates a potentially hazardous situation which, if not avoided, could result in death or serious injury.

CAUTION

Indicates a potentially hazardous situation which, if not avoided, may result in minor or moderate injury.

NOTICE

Indicates that equipment or property damage can result if instructions are not followed.

SAFETY INSTRUCTIONS

Safety instructions (or equivalent) signs indicate specific safety-related instructions or procedures.

Note: Contains additional information important to a procedure.

2.3 Safety Rules

Accidents can often be avoided by being alert and recognizing potentially hazardous situations. Any individuals installing, operating, repairing, or maintaining products manufactured by Anthony Liftgates should have the necessary training, skills, and tools required to perform these functions properly and safely. The safety information in this manual serves as a basic guide in an attempt to prevent injury or death.

Anthony Liftgates cannot anticipate every possible circumstance that might involve a potential hazard. The warnings in this manual and on the product itself are, therefore, not all-inclusive. If tools, procedures, work methods, or operating techniques that are not specifically mentioned by Anthony Liftgates are used, you must satisfy yourself that they are safe for you and for others. Make sure the liftgate or truck it is mounted onto will not be damaged or made unsafe by any operation, lubrication, maintenance, or repair procedures that you choose.

DO NOT proceed, if any doubt arises about the correct or safe method of performing anything found in this or other Anthony Liftgates' manuals. Seek out expert assistance from a qualified person before continuing.

WARNING



To avoid personal injury or death, carefully read and understand all instructions pertaining to the Anthony Liftgates product. Do not attempt to install, operate, or maintain our product without fully understanding all of our instructions and safety recommendations. Do not operate or work on a truck or liftgate unless you read and understand the instructions and warnings in the Installation and Operation manual. If any doubt or question arises about the correct or safe method of performing anything found in this or other Anthony Liftgates' manuals, contact your Anthony Liftgates' dealer or call the Inside Sales and Service representatives at our main headquarters. Proper care is your responsibility.

⚠️ WARNING



To prevent serious bodily injury, keep sparks, lighted matches, and open flames away from the top of the battery, because battery gas can explode. Always follow all the manufacturers' safety recommendations when working around the truck's battery.



Take precautions to avoid sparks coming into contact with the truck's fuel tank, brake lines, or other flammable components. Sparks can cause an explosion of combustible materials, resulting in serious injury or death.



Never secure the power cable to anything which allows it to contact sharp edges, other wiring, the fuel tank, fuel lines, brake lines, air lines, exhaust system, or any other object that could cause the power cable to wear or be damaged. A cut battery cable can cause sparks resulting in loss of vehicle control, serious injury, or even death.



If required for installation, always use a cutting torch in a well ventilated area and, if in an enclosed area, vent the fumes to the outside. Breathing the smoke and fumes can cause serious injury.



Always follow all State and Federal health and safety laws and/or local regulations when using a cutting torch. Also, follow all manufacturer's safety guidelines. If other people are present during the installation of the liftgate, make sure they remain clear of the cutting area.



To avoid eye injury, always wear eye protection with the proper lens to protect your eyes.



Failure to prevent the truck from moving during the installation of the liftgate could result in a serious crushing injury.



Do not work under the liftgate while it is suspended from the lifting equipment. Failure of the lifting equipment could cause serious crushing injuries. Do not remove the lifting equipment until the liftgate is completely bolted onto the truck frame.



To prevent personal injury, clean up any spilled fluids immediately. To avoid tripping, do not leave tools or components laying around in the work area.

⚠️ CAUTION



Anthony Liftgates recommends not riding the liftgate, however, if the delivery operation requires it, make sure your footing is stable before raising or lowering platform. Always stand away from the edge. When on the ground, always stand clear of liftgate when it is operating.



Always use/set the truck's parking brake before operating the liftgate. Failure to follow this recommendation can result in injury.



Do not place hands or feet in pinch points.



Do not place your feet under the liftgate.

SAFETY INSTRUCTIONS



To prevent injury, the liftgate and its related components should only be installed by a qualified installer. They should have knowledge and skill in using lifting equipment and a cutting torch.



To prevent possible injuries due to improper operation, make sure all decals are attached to the liftgate and/or truck and are legible at all times.

2.4 Safety Icons Nomenclature

This manual and the equipment has numerous safety icons. These safety icons provide important operating instructions which alert you to potential personal injury hazards.

2.4.1 Personal Protection/Important Information



Read the manual



Damaged Safety Signs



Use proper tools



Use two people when lifting heavy objects



Weight rating



Eye protection



Breathing protection



Inspect Equipment



Set parking brake

2.4.2 Prohibited Actions



No smoking



No open flame

2.4.3 Hazard Avoidance



Slipping injury



Tripping injury



Safety alert symbol



Pinch point hazard



Explosion hazard



Dangerous fumes



Tire Pressure



Adequate ventilation



Crush hazard



Crush hazard (chock wheels)



Fall hazard



Crush hazard (foot)

3. Nomenclature

3.1 Platform nomenclature.

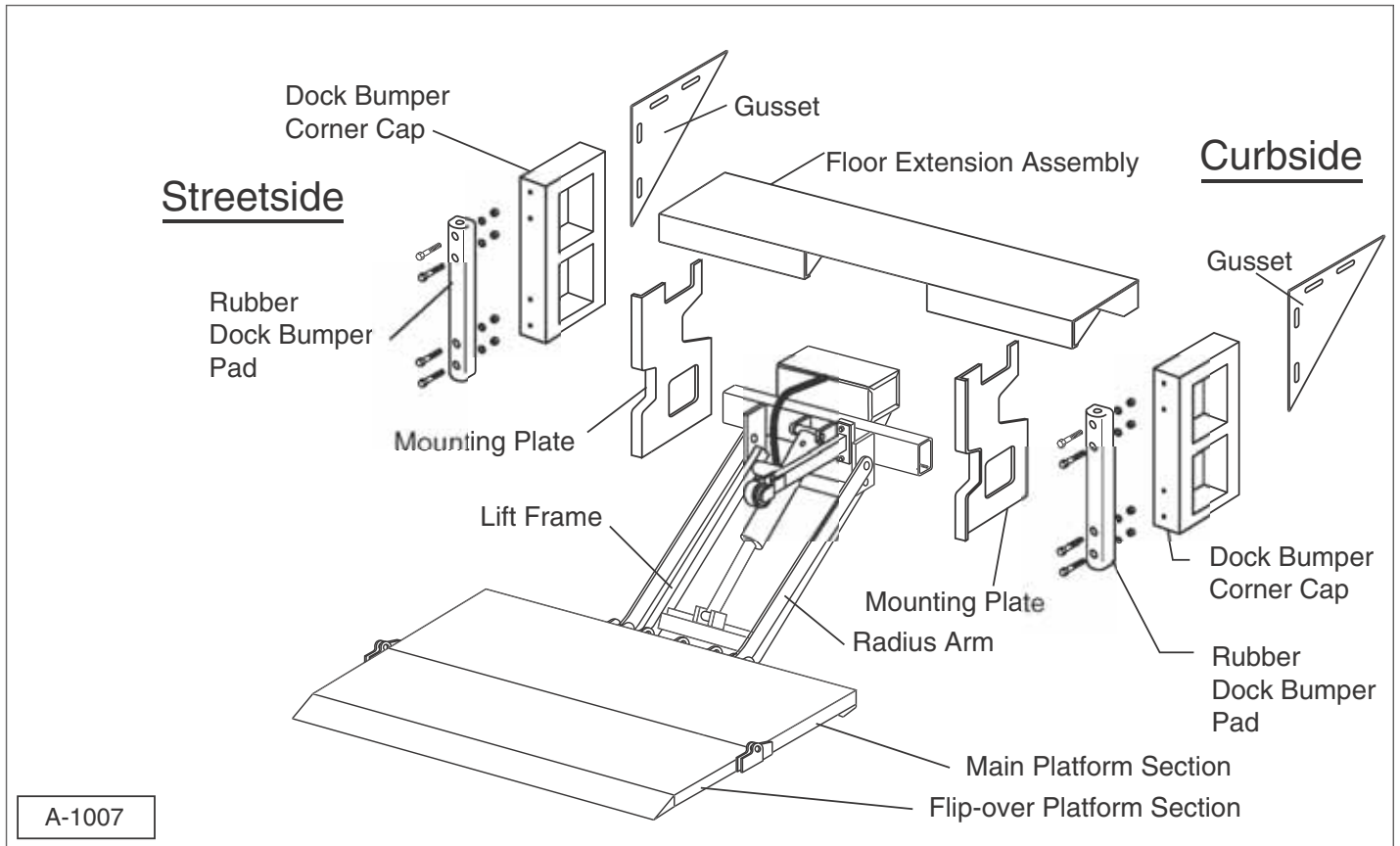

3.2 Gravity-Down Power Unit Nomenclature.

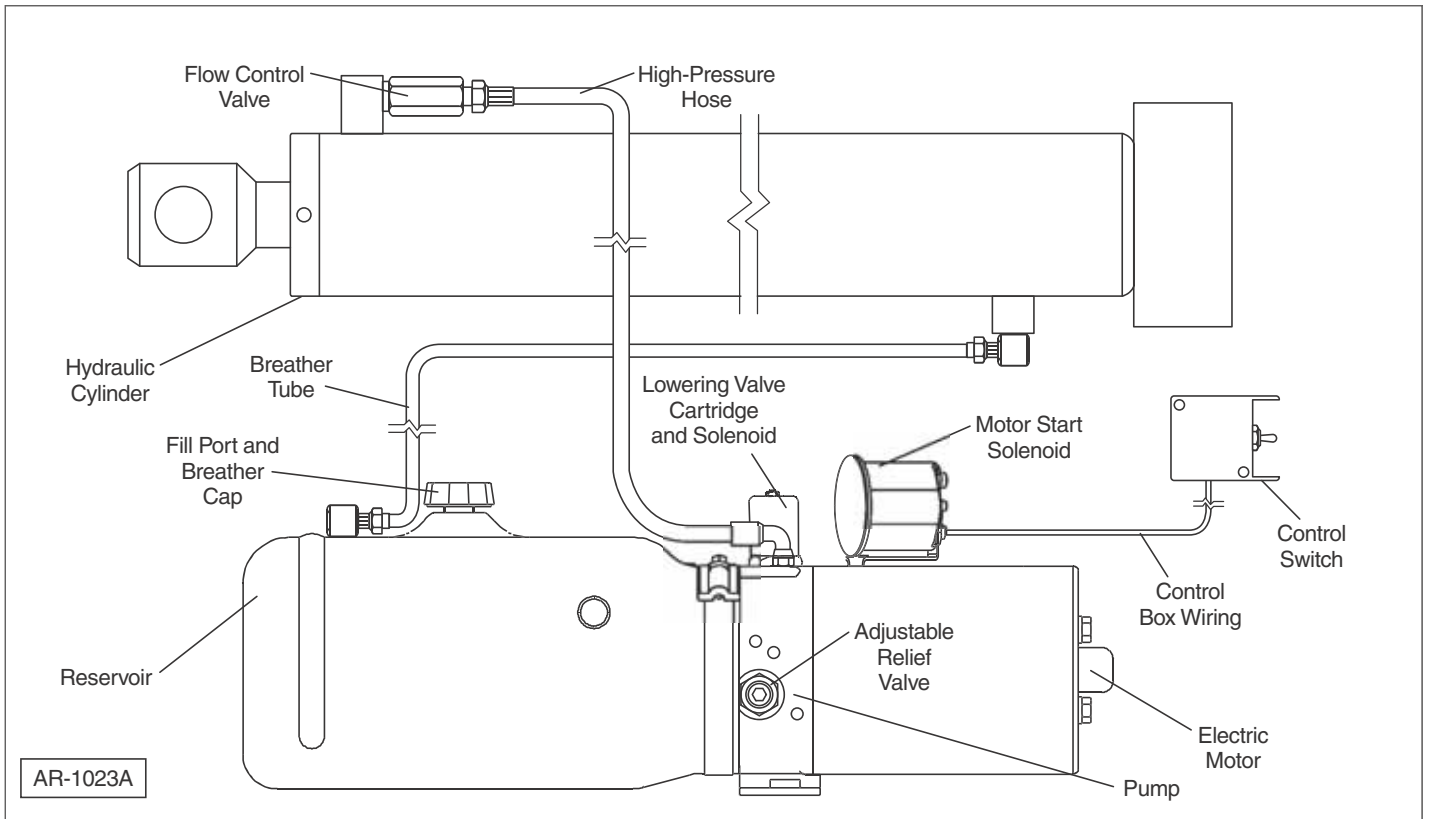

3.3 Power-Down Power Unit Nomenclature.

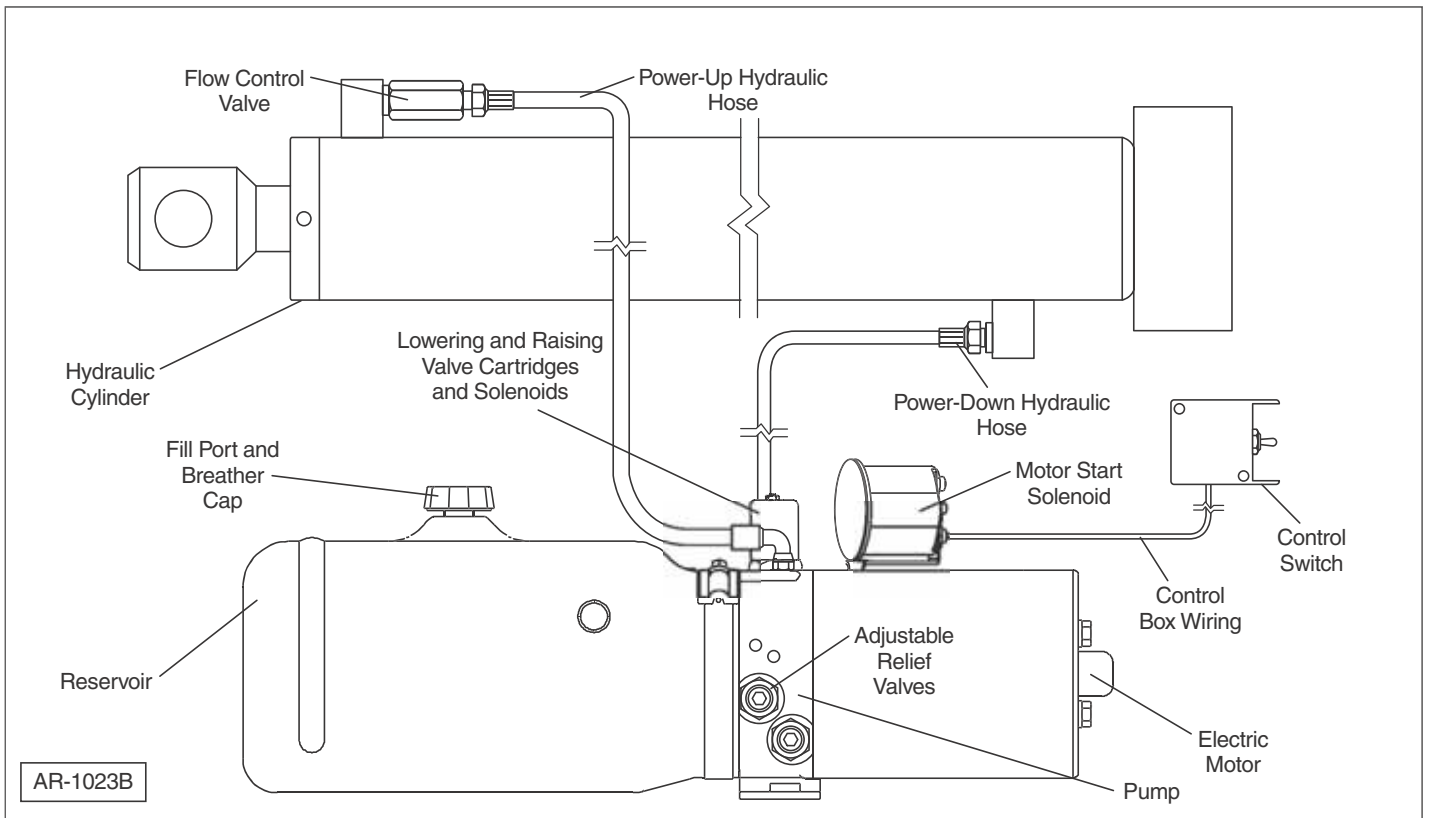

4. Installation Section

WARNING



To prevent serious bodily injury, keep sparks, lighted matches, and open flames away from the top of the battery, because battery gas can explode. Always follow all the manufacturers' safety recommendations when working around the truck's battery.



Take precautions to avoid sparks coming into contact with the truck's fuel tank, brake lines, or other flammable components. Sparks can cause an explosion of combustible materials, resulting in serious injury or death.



Never secure the power cable to anything which allows it to contact sharp edges, other wiring, fuel tank, fuel lines, brake lines, air lines, exhaust system, or any other object that could cause the power cable to wear or be damaged. A cut battery cable can cause sparks resulting in loss of vehicle control, serious injury, or even death.



Always weld in a well ventilated area and, if in an enclosed area, vent the fumes to the outside. Breathing welding smoke and paint fumes can cause serious injury.



Always follow all State and Federal health and safety laws and/or local regulations when using an arc welder, mig welder, or cutting torch. Also, follow all manufacturer's safety guidelines. If other people are present during the installation of the liftgate, make sure the welding area is shielded from their view.



To avoid eye injury during welding, always wear a welding helmet with the proper lens to protect your eyes.



To prevent personal injury, clean up any spilled fluids immediately. To avoid tripping, do not leave tools or components laying around in the work area.



Failure to prevent the truck from moving during the installation of the liftgate could result in a serious crushing injury.



Do not work under the liftgate while it is suspended from the lifting equipment. Failure of the lifting equipment could cause serious crushing injuries. Do not remove the lifting equipment until the liftgate is completely welded onto the truck frame.

SAFETY INSTRUCTIONS



To prevent injury, the liftgate and its related components should only be installed by a qualified installer. They should have knowledge and skill in using welding equipment and a cutting torch.



To prevent possible injuries due to improper operation, make sure all decals are attached to the liftgate and/or truck and are legible at all times.

4.1 Tools Required

The following is a list of suggested tools that should be used to install the liftgate.

- Overhead Crane or Forklift
- Mig or Stick Welder
- Heavy-Duty C-Clamps
- Tape Measure
- Level (small, magnetic)
- Cutting Torch (in some applications)
- Wrenches (bolt-on models only)

4.2 Bed Height Requirements

NOTICE

Make sure the model being installed is compatible with the bed height of the truck.

Mounting Requirements		
Model	Lifting Capacity	Bed Height*
AXM-1500-SF	1,500 lb.	36" - 56"
AXM-2000-SF	2,000 lb.	
AXM-2500-SF	2500 lb.	
ASTL-1800-SF	1,800 lb.	36" - 44"
ASTL-2500-SF	2,500 lb.	
ATU-1800LB-SF	1,800 lb.	
ATU-2500LB-SF	2,500 lb.	38" - 56"
AST-Plus-2500-SF	2,500 lb.	
ATU-GLR-25-SF	2,500 lb.	42" - 55"
ATU-GLR-3000	3,000 lb.	42" - 55"
AST-1500-SF	1,500 lb.	42" - 57"
AST-2000-SF	2,000 lb.	
AST-2500-SF	2,500 lb.	
AST-3000-SF	3,000 lb.	
ATU-1800-SF	1,800 lb.	
ATU-2500-SF	2,500 lb.	
ATU-3000-SF	3,000 lb.	
ATU-3500-SF	3,500 lb.	
ATU-1800A-SF	1,800 lb.	
ATU-2500A-SF	2,500 lb.	
ATU-3000A-SF	3,000 lb.	

* The first dimension is the minimum height when the truck is fully loaded. The second dimension is the maximum height when the truck is unloaded (empty).

4.3 Unpackaging

Make sure the complete package is received. On steel platform liftgates, all the necessary parts are packaged on one pallet.



Aluminum platform liftgates have the loose parts shipped in a separate box.



4.4 Lifting Device

When installing several liftgates a year, the following lifting device can save time and make the installation process more efficient.



Installer-built Lifting Device.

This lifting device must be made specifically for the type and design of the particular forklift used in the installation. Remember, the materials used to construct the lifting device must be capable of lifting and supporting the liftgate being installed. The lifting device must also contain a retaining method to hold it onto the forklift.



- Make the lifting device from tubular steel at least 1/4 inch thick or thicker.
- Make the lifting device wide enough to support the liftgate and to accommodate the width of the forks on the forklift.
- Make the lifting bolt from 5/8 inch threaded rod. Use a washer and nut to fasten the lifting device to the liftgate.
- The lifting bolt should be long enough to go through the lifting hole in the liftgate and allow the lifting device to remain level.

⚠ WARNING



CRUSH HAZARD

The construction of the lifting device must satisfy the user to be safe and properly constructed. Failure to use the proper materials or material thickness can result in serious injury or death.

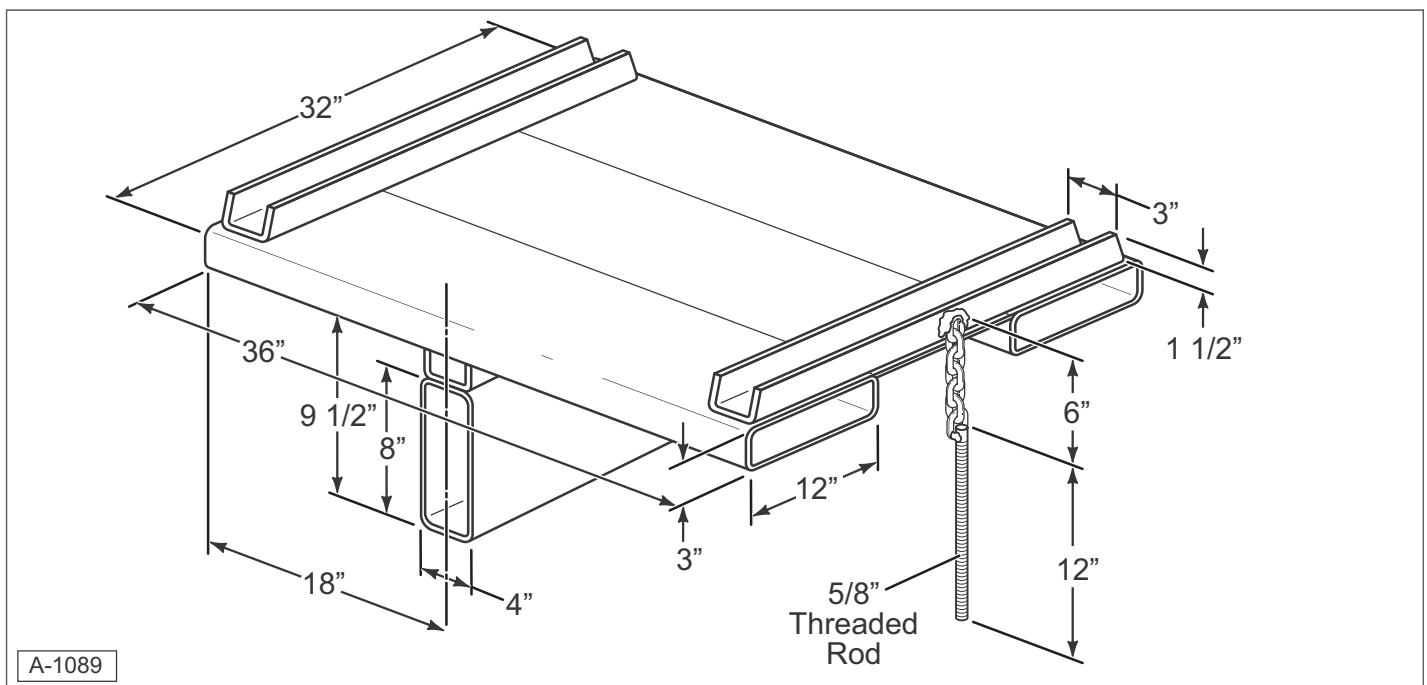

4.5 Prior to Installation

Note: Check the OEM vehicle manual for any special requirements prior to welding on the truck. If required, disconnect the battery cable before welding on the truck frame.

WARNING



Rollover Hazard

Failure to prevent the truck from moving during the installation of the liftgate could result in serious personal injury or death.

1. Place the truck on a flat, level surface. Block the wheels to prevent possible truck movement during liftgate installation.
2. Use the Mounting Requirements illustrations and charts to make sure there is enough clearance to properly install the liftgate.
3. The dimensions in the following charts are to only be used as a guide for what can be expected for clearances needed. They DO NOT have to be exact, unless you are near the extreme high or low-end of the bed height mounting range. If not, they can vary and should not alter the functionality of the liftgate.

Mounting Requirements		
A Bed Height Floor Extension	B Bed to Top of Tube Assembly	C Mounting Plate
36" - 41"	15-3/4"	29"
42" - 49"	19"	24-1/4"
50" - 51"	20"	23-3/4"
52" - 53"	21"	23-1/4"
54" - 55"	22"	22-5/8"
56" - 57"	23"	22-1/2"

4. Remove the banding securing the liftgate and loose parts to the pallet. Remove the curbside and streetside mounting plates from the liftgate frame. Unfold the liftgate, as shown.

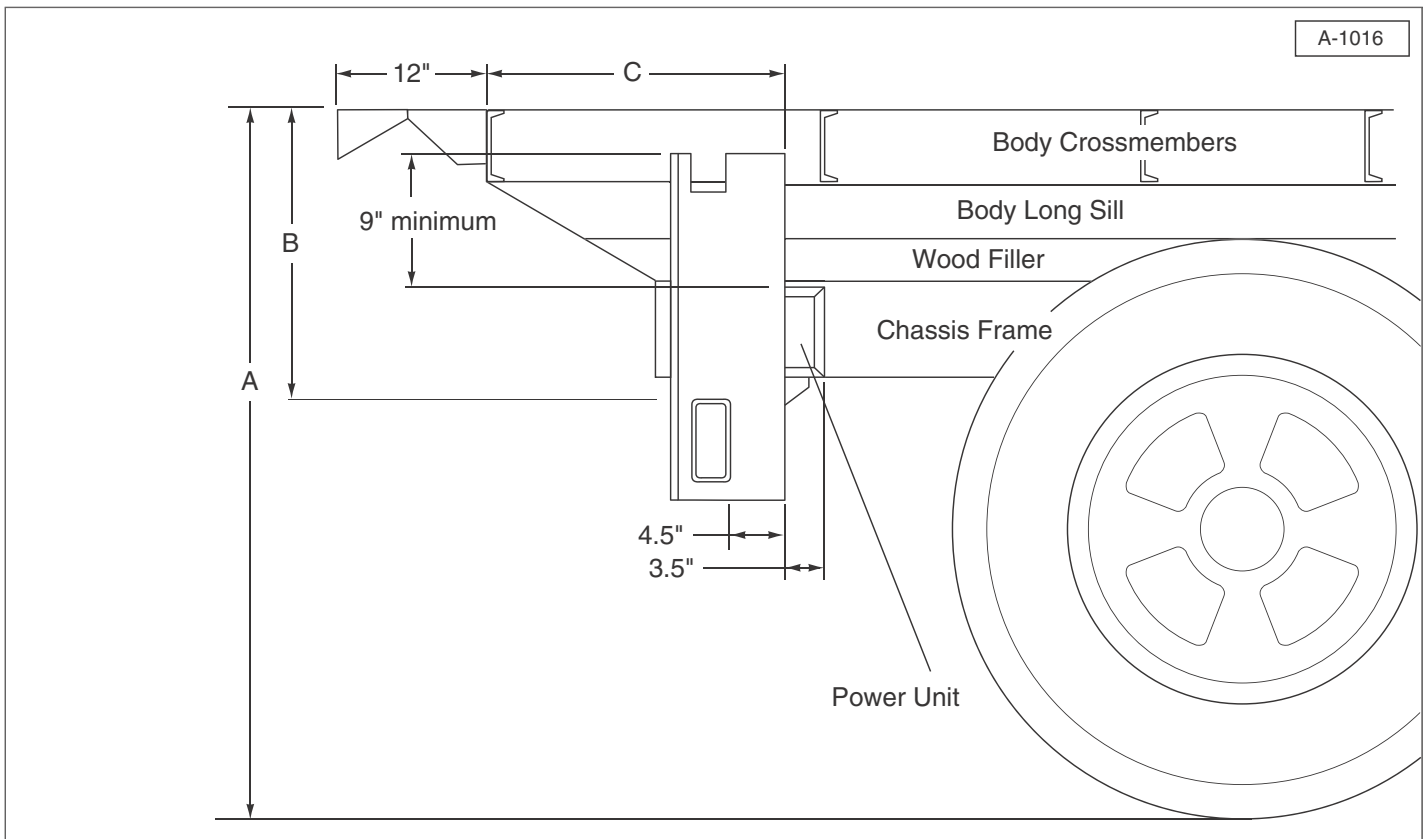
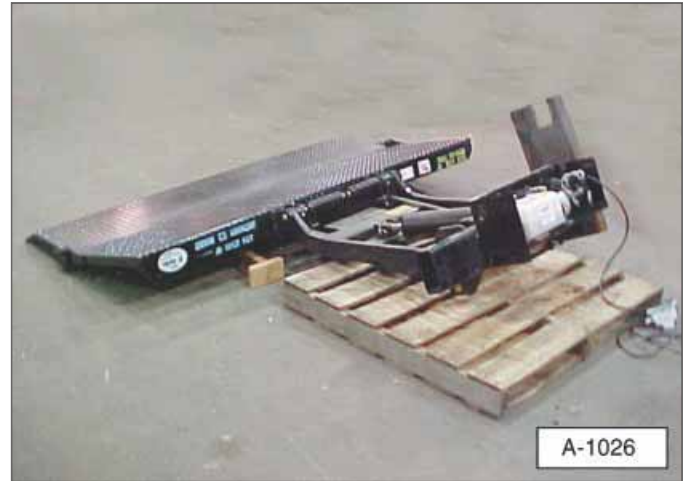

Refer to the Mounting Requirements chart for dimensions.

ATU-GLR Mounting Requirements		
A Bed Height Floor Extension	B Bed to Top of Tube Assembly	C Mounting Plate
42" - 55"	19"	24-1/4"

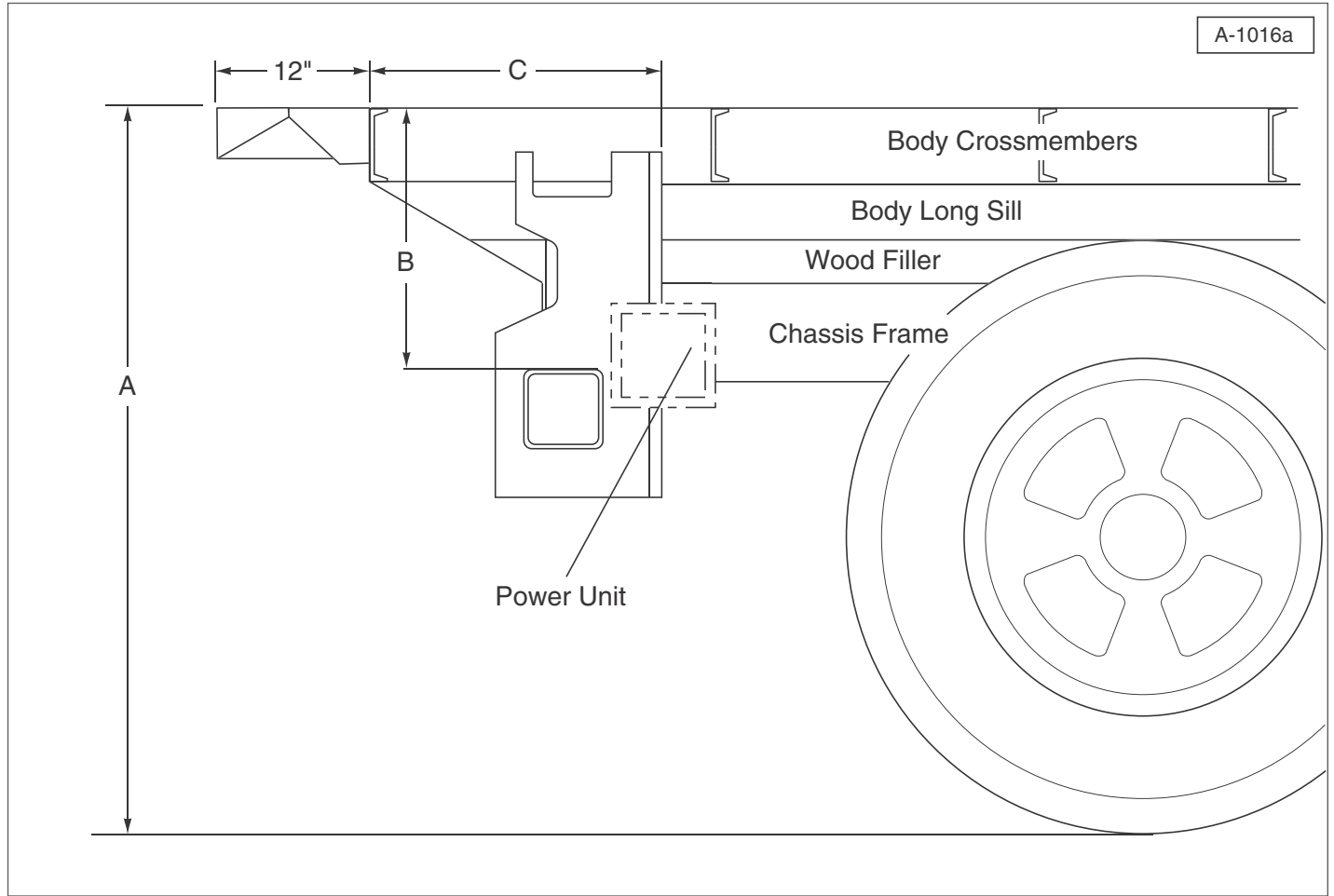

Refer to the ATU-GLR Mounting Requirements chart for dimensions.

4.6 Installation Procedure

SAFETY INSTRUCTIONS



Even though the Anthony liftgate is easy to install, the installation should be done with at least two people.

1. Remove the cover from the power unit box. Remove all loose parts for the assembly process and the instructions from inside the box. Replace plug in the power unit reservoir with supplied breather cap (1).



Note: The power unit box should contain plastic tie wraps for the battery cable, two platform supports, one radius arm locking plate, one 200 Amp fuse, and one package containing decals, shims, and manuals.



2. Cut off or extend the chassis frame, wood filler, and body long sill, as shown in the illustration. The end of the frame must be 0 to 12 inches forward of the rear of the truck body.

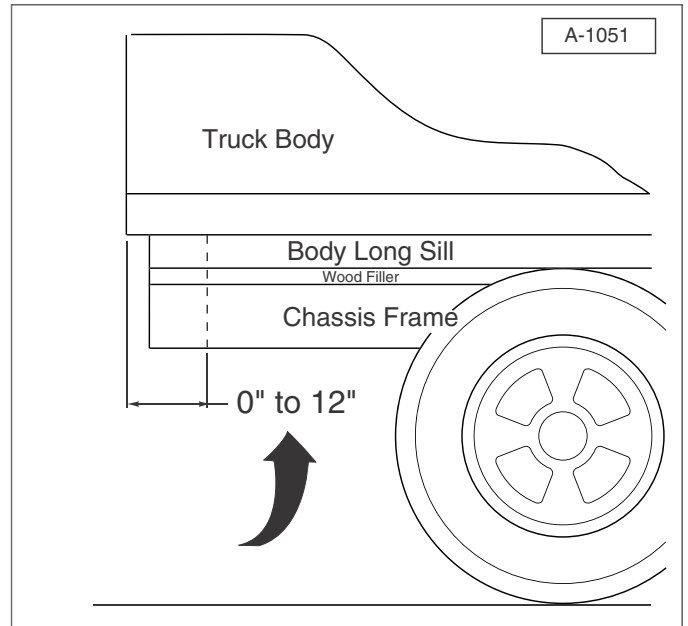

: Before extending the truck chassis, make sure the extensions meet the specifications of the truck manufacturer and that altering the frame will not void the truck warranty.

3. Measure and determine the center of the truck's rear sill. Mark this point.



4. Install the floor extension. For the weld-on type floor extensions, proceed to Step 5. For the bolt-on type floor extensions, go to "5.1 Bolt-On Floor Extension" on page 31.
5. Installing the weld-on floor extension.
 - a. Center the floor extension on the truck body. With the extension level with the floor of the truck, begin tack welding at the center. The floor extension has a natural bow in it and must be straightened as it is installed.

CAUTION



CRUSH HAZARD

The tack welds must be strong enough to hold the weight of the liftgate. Insufficient welds may not hold the liftgate in place, resulting in possible bodily harm.

- b. Continue tack welding from the center out, making sure the extension remains level (flush) with the floor. The tack welds must hold the weight of the floor extension and dock bumpers, approximately 200 pounds.



- c. Make sure the floor extension is level and parallel to the truck's rear sill.



- d. Tack weld the support brackets under the floor extension to the truck body.



- e. Finish welding the floor extension to the truck body. Weld between the white dots painted on the floor extension (approximately 2 inches each).
 - f. Weld the support gussets under the floor extension to the truck body on both sides of the gusset.
6. Using a forklift or overhead lifting equipment, position the liftgate on the truck frame.

WARNING



Crush Hazard

Do not work under the liftgate while it is suspended from the lifting device. Failure of the lifting device could cause serious crushing injuries. Do not remove the lifting device(s) until the liftgate is completely welded onto the truck frame.

- a. Use a forklift or overhead crane to position the liftgate. The lifting device described in "4.4 Lifting Device" on page 15 is shown in the photos; however, any lifting device capable of safely lifting and holding the liftgate can be used.

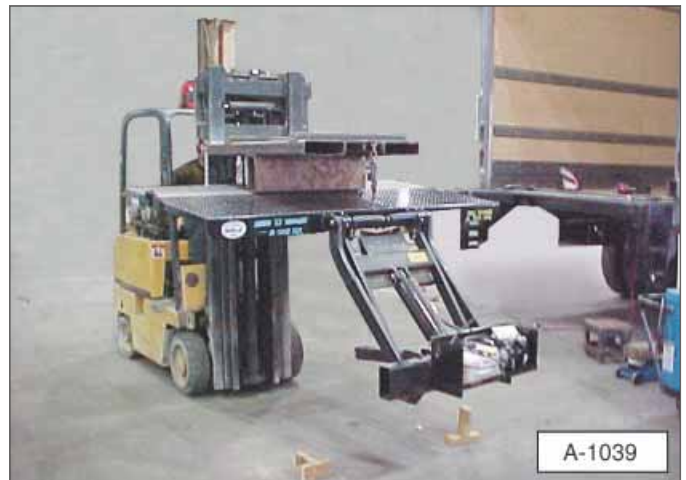

- b. Position the edge of the liftgate slightly above the floor extension and centered side-to-side. The outer edge of the liftgate should be elevated higher than the edge against the floor extension, as shown.

Note: Positioning the liftgate approximately 1/8 inch above the floor extension allows the liftgate to be flush after welding (due to settling).

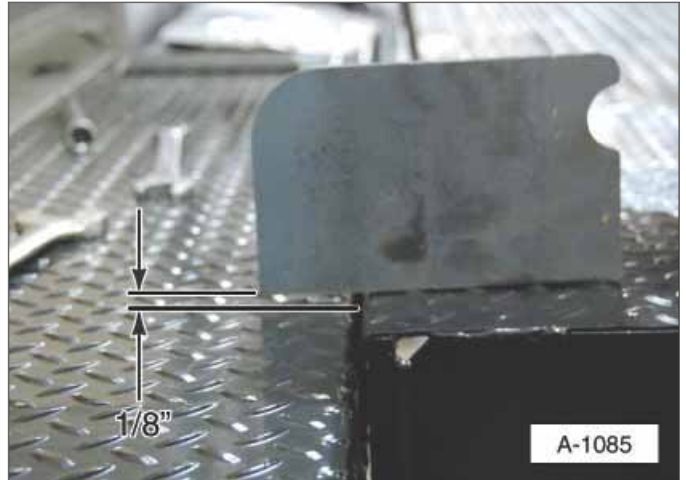
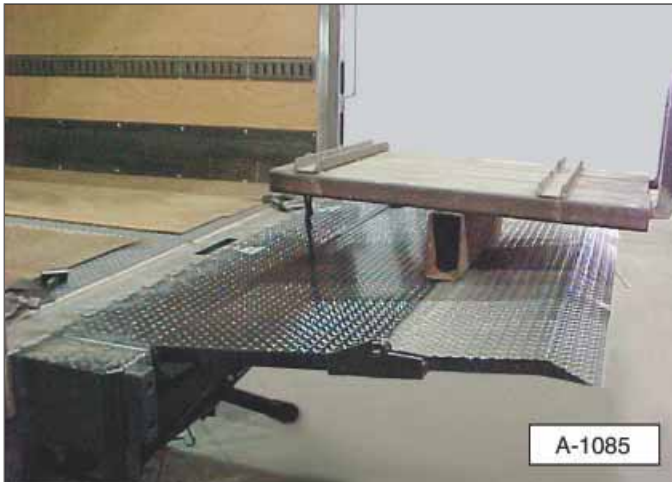

7. Clamp the liftgate onto the floor extension.

- a. Use two large C-clamps, as shown below, to hold the liftgate in place.

- b. An alternate method of holding the liftgate in place is using two, 3 to 4 feet long pieces of heavy-duty angle iron. The size of the angle iron should be 3 x 3 x 1/4 inch minimum.

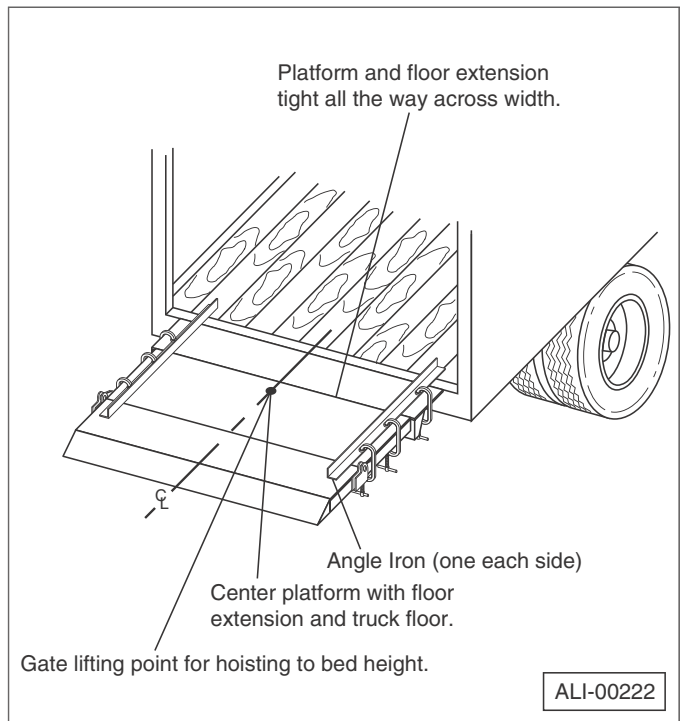
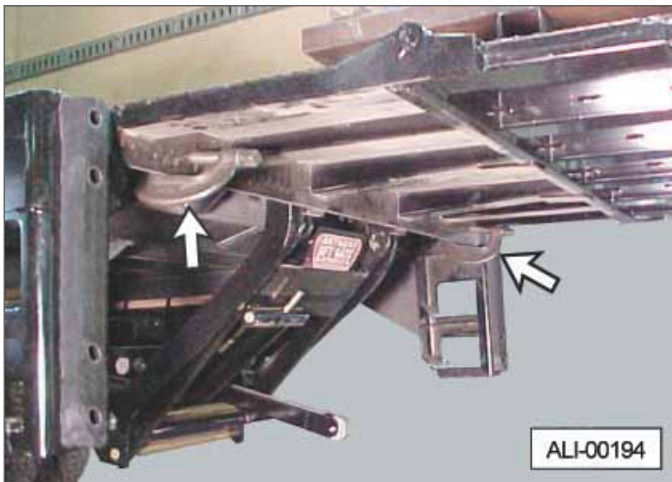

- c. When correctly installed the position of the outer edge of the liftgate should be 1/2 to 3/4 inches higher than the edge against the floor extension, as shown.

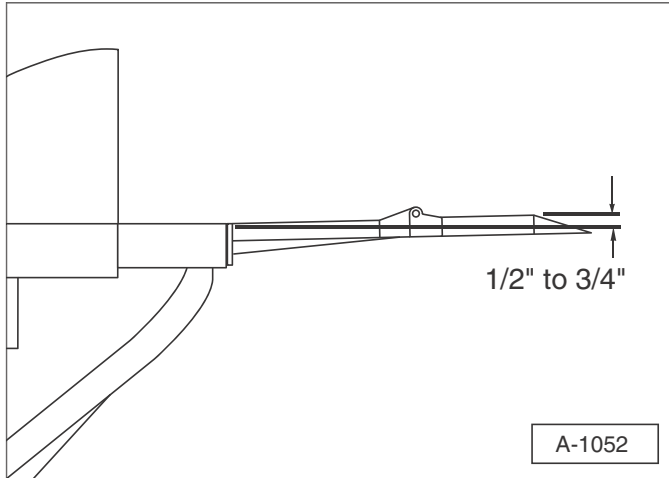

8. Route the supplied power cable (with attached fuse assembly) from the battery to the liftgate power supply using only one of these three methods.

• Direct Battery Connection

This method is not recommended because it allows the unauthorized use of the liftgate when the truck is unattended. Refer to “4.7.1 Direct Battery Connection (not recommended)” on page 27.

• Cut-Off Solenoid Connection

To prevent unauthorized use, use “4.7.2 Cut-Off Solenoid Connection” on page 28.

• Cut-Off Switch Connection

To prevent unauthorized use, use “4.7.3 Cut-Off Switch Connection” on page 28.



⚠ WARNING



Loss of Vehicle Control

Never secure the power cable to anything which allows it to contact sharp edges, other wiring, the fuel tank, fuel lines, brake lines, air lines, exhaust system, or any other object that could cause the power cable to wear or be damaged. A damaged battery cable can result in loss of vehicle control, causing serious injury or death.



Unauthorized Use

Anthony Liftgates strongly recommends the installation of a power cut-off solenoid (“4.7.2 Cut-Off Solenoid Connection” on page 28) or cab cut-off switch (“4.7.3 Cut-Off Switch Connection” on page 28). Allowing power to the liftgate when the truck is unattended can result in serious injury or death.

NOTICE

The liftgate must be properly grounded. A ground wire, the same gauge or larger as the liftgate power cable, must be connected from the negative post of the battery or batteries to the truck’s frame. If the truck is properly grounded, no further action is required. If the truck is not properly grounded, add a ground wire. If this recommendation is not followed, damage to the truck may occur. Improper grounding can cause the electrical current to travel through brake lines, steel braided power steering hoses, or other chassis wiring causing failure to these components! Failure of these components could result in loss of vehicle control.

9. Place a floor jack under the wheel arm, as shown. Raise the wheel arm until the adapter frame is almost perpendicular to the truck frame.



Note: To ensure the lifting platform will remain level with the floor extension after normal wear, tilt the mounting plates and adapter frame tube slightly towards the cab of the truck until approximately 1/4 inch of the cylinder rod chrome is extended. When positioning the adapter frame on a power down model, it can be positioned by simply operating the liftgate with the switch (down). For positioning with a gravity down model, hold the switch down to bleed off pressure from the cylinder so it can be raised into position with the jack.

10. Slide the mounting plates into position on the adapter frame tube on each side and tack weld in place. Place tack welds at the locations marked "X" (each weld should be a 3/8" fillet, 1 inch long). The angle on the plate should face the rear of the truck, as shown.

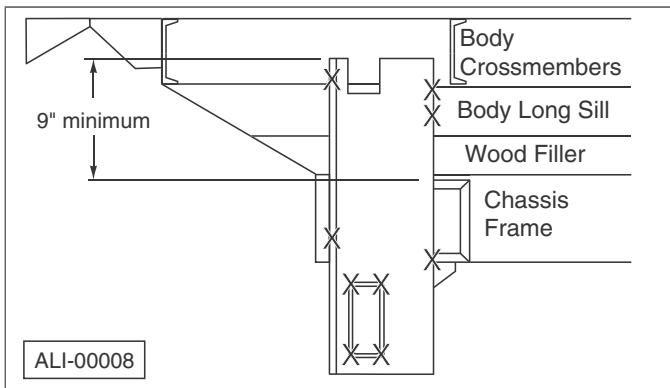

Typical liftgate models.

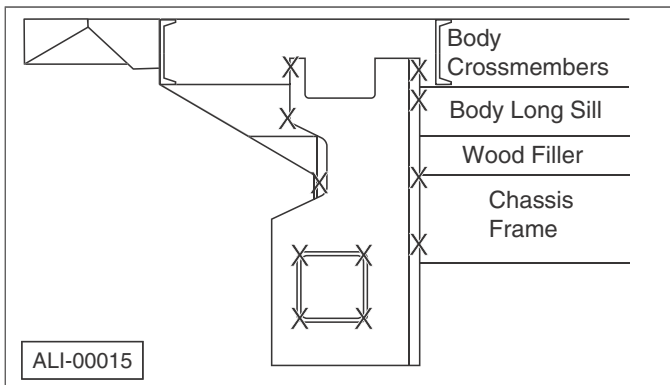

GLR liftgate models.

Note: Make sure the notched section of the mounting plate is installed toward the rear of the truck.

11. Remove the C-clamps, angle iron (if this method was used), lifting equipment, and jack.

NOTICE

FOR GLR MODELS ONLY

Remove installation nuts and bolts!

On "GLR" model liftgates only, remove the two bolts and nuts, located on the "adapter frame" and "rocker assembly", as shown in the photo. This hardware must be removed and discarded after installation.



ATU-GLR Installation Bolt.

12. Standing on the curbside of the truck, away from the platform, actuate the DOWN switch to lower the platform to the ground and the UP button to raise the platform back to truck bed height.

- a. Typical Tuckunder Models: If the platform lowers to the ground and raises flush to the floor extension, finish welding the mounting plates. If the platform does not make a complete cycle, adjust the mounting plates, as necessary.
- b. ATU-GLR Models: This platform raises and lowers with the platform level, or parallel to the truck floor. The platform begins tilting downward once the rollers make contact with the ground, and will continue to tilt until the platform's ramp edge (tapered edge) contacts the ground.

When the platform is raised, the ramp edge tilts upward until the platform is level. The platform then raises, until it stops at the truck floor level.

**SAFETY
INSTRUCTIONS**



For safety purposes, finish welding the liftgate while the platform is on the ground, not in a raised position.

NOTICE

Cover the cylinder rod to prevent weld spatter from damaging it.

13. With the liftgate on the ground, completely weld the mounting brackets onto the chassis frame and tube assembly.

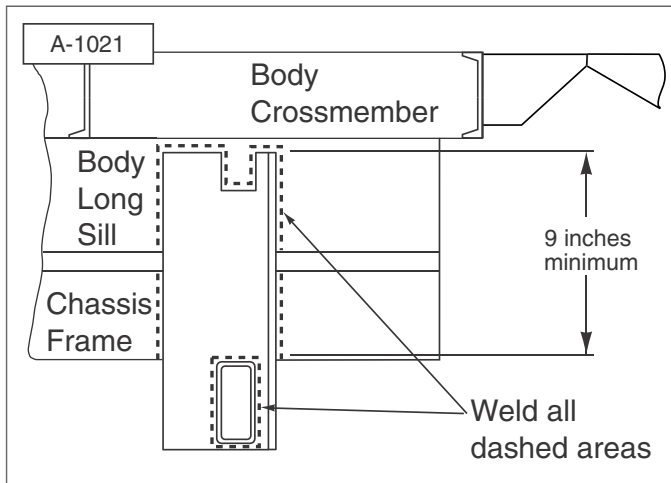

Typical liftgate models.

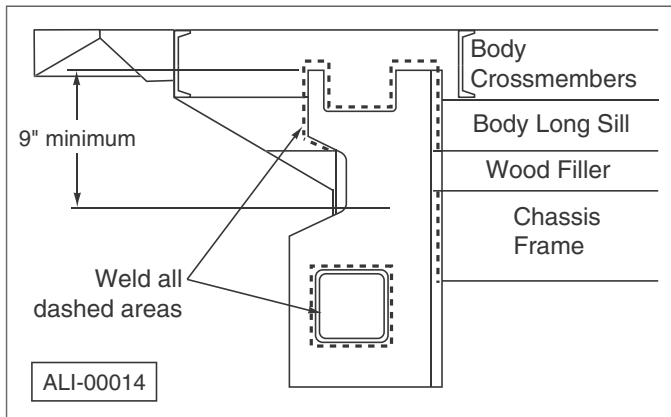

GLR liftgate models.

CAUTION



Take precautions to avoid welding sparks or the flame from a cutting torch coming into contact with the truck bed's wooden floor or other flammable components.

14. Cut the chassis frame and body long sill, as shown in the following illustration. After making the cut, make sure the liftgate operates properly without interfering with the chassis frame or body long sill.

Chassis Frame Length			
Bed Height Floor Extension	B	C	E
36" - 41"	15-3/4"	13-1/2"	3-3/4"
42" - 49"	19"	14-3/4"	4-1/4"
50" - 51"	20"	14-1/4"	5-1/8"
52" - 53"	21"	13-3/4"	5-3/4"
54" - 57"	22"	13-1/8"	6-1/4"

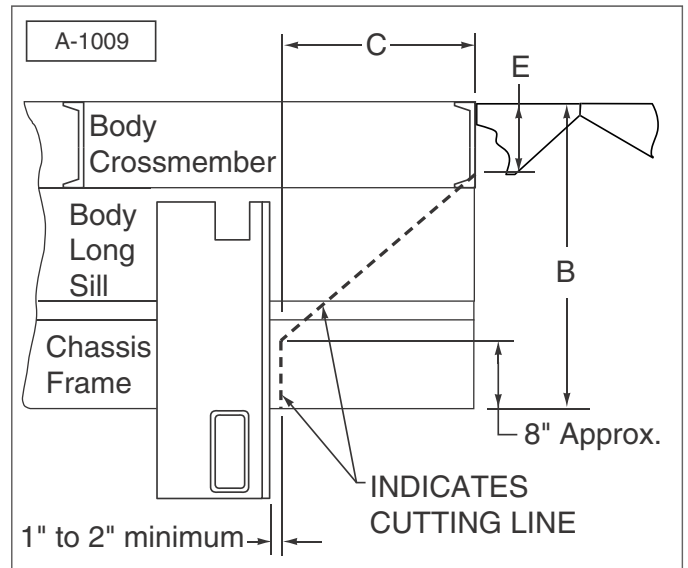

15. Position the liftgate and weld the platform supports in place as follows:

- Fold the liftgate into the storage position. Using the up and down switch, position the liftgate until there is a 1/2" gap between the cylinder body and liftgate.

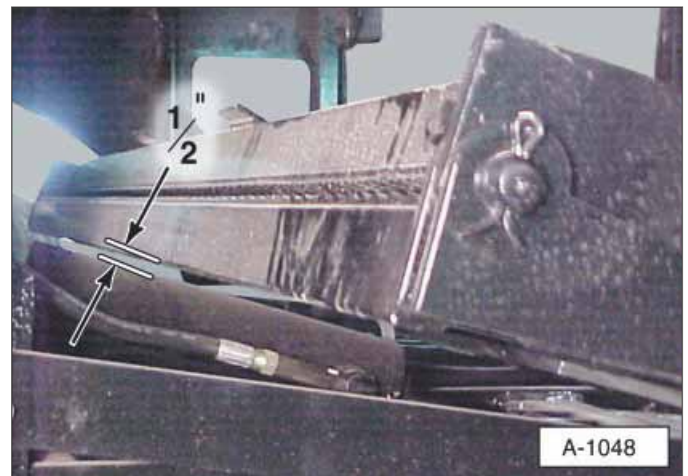

- b. Position and tack weld the platform supports 1/16" to 1/8" from the platform on each side. If the liftgate operates properly, weld them in place on all three sides.

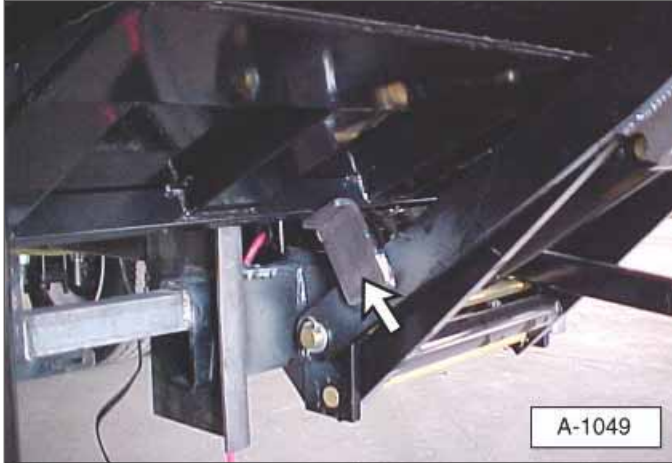

- c. Weld the locking plate in two places with 3/8" fillet welds, as shown.

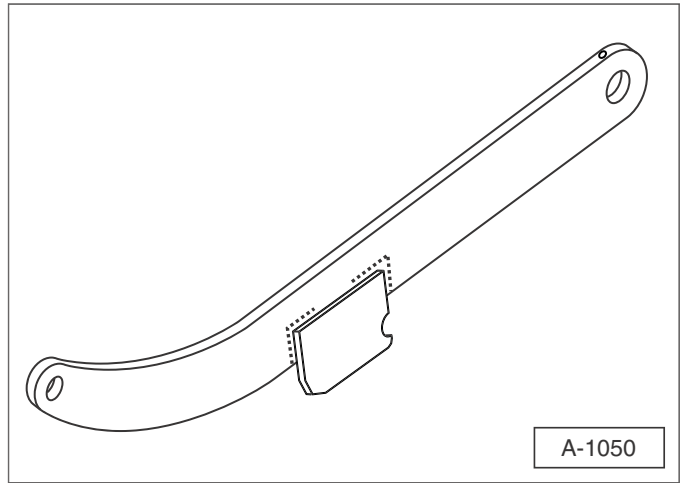

NOTICE

The latch pin is only for in-transit locking of the liftgate. DO NOT slide the latch pin into the latched position when the platform is unfolded and raised. If this occurs, serious damage to the liftgate can occur when the liftgate is lowered.

- 16. Attach the locking plate to the radius arm as follows:

- a. Raise the liftgate to the stored position and slide the latch pin across the radius arm.
- b. Position the locking plate on the streetside radius arm, as shown. There should be a 1/16" gap between the radius on the locking plate and the latch pin.

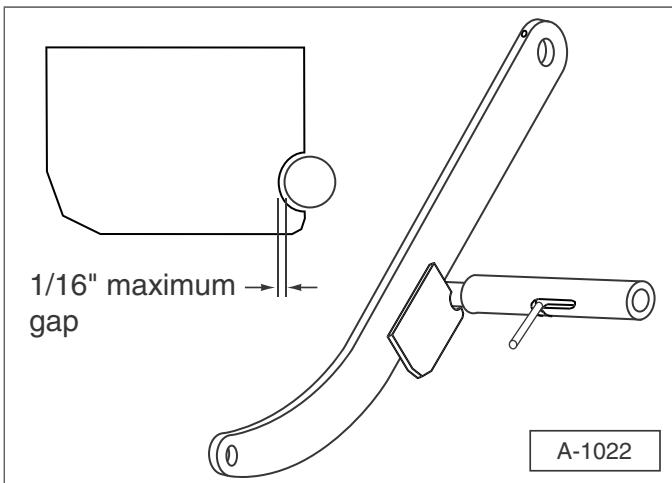

- 17. Mount the control switch to truck's rear curbside post so it can be reached while standing at the curbside of the truck away from the liftgate platform.

Note: On weld-on type installations, mount the switch box before attaching the dock bumpers. This allows routing of the switch box wire through the slot in the dock bumper.



**SAFETY
INSTRUCTIONS**



Many liftgate models provide drivers' steps as a convenience feature. When steps are present, customer-supplied grab handles and other ingress/egress items should be installed.

18. Weld both the streetside and curbside dock bumpers onto the floor extension.
 - a. If necessary, route the control cable through the curbside dock bumper.
 - b. Hold the dock bumper corners in place and tack weld into position.
 - c. Weld the dock bumper corners continuously to the floor extension and the truck body.



Note: Place a wet shop towel or rag around the switch box control cable when welding the curbside dock bumper to prevent burning or melting the control cable.

19. Install the side gussets.

- a. The recommended method of attaching the side gusset is to weld it to the steel side member of the truck body.

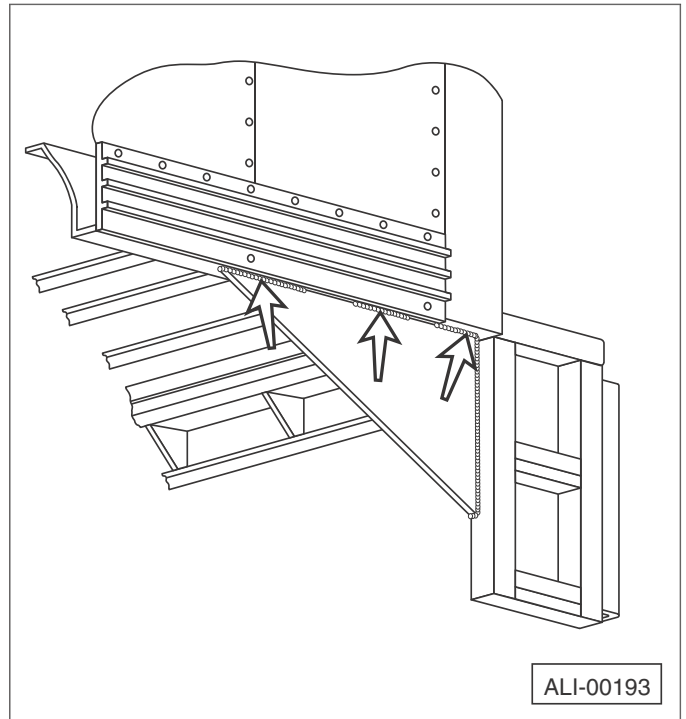

- b. The alternate method of attaching the side gusset is to weld it to the steel cross-members of the truck body. The gusset should be welded on both sides of at least three cross members.

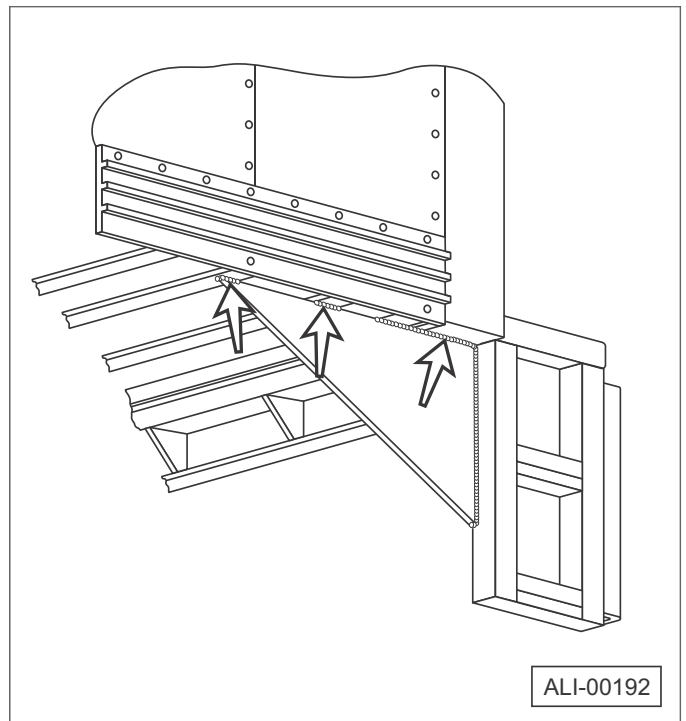

WARNING



Crush Hazard

Never stand behind the liftgate when it is opened. Always stand to the side and away from the edge of the platform.

When adjusting the position of the wheel arm, consider that the vehicle may be parked on a sloped surface. In this event, the platform may completely unfold all the way to the ground, resulting in serious injury. When adjusting the wheel arm, choose a position that will not allow this to occur.

20. Test and adjust the wheel arm.

The wheel arm helps unfold the platform as it is lowered from the stored position. The wheel arm can be adjusted so the platform unfolds with either greater or lesser effort.

The position of the wheel on the arm should be adjusted so that the platform, when lowered, is in the most upright and vertical position, without falling open. The platform will be easier to unfold in this position.

Adjust the wheel arm as follows:

- Remove two bolts and nuts on the wheel arm channel.
- Lengthen or shorten the wheel and channel assembly on the tube, as needed.
- Align the two holes in the wheel and channel assembly with the holes in the tube nearest the position desired.
- Re-install the two bolts and nuts. Tighten the nuts to secure the wheel and channel assembly.

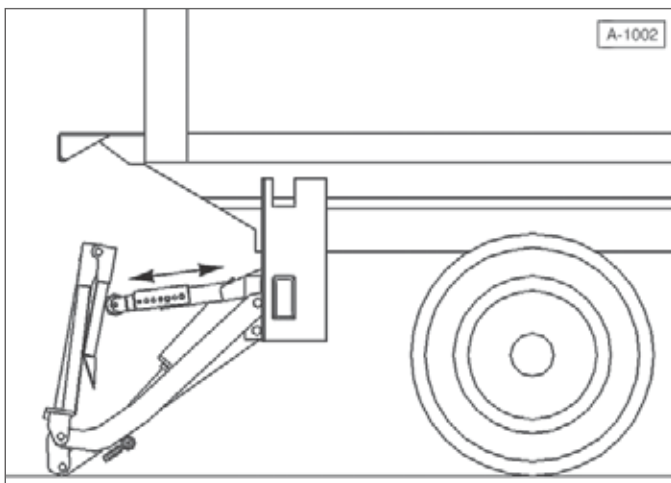

21. Install lights or other electrical components.

22. If required, install grab bars or hand rails. Also, install the license plate holder.

NOTICE

Some models of Anthony liftgates may be provided with step devices to assist in the ingress or egress into the rear of the truck or trailer. These devices are NOT to be considered all-inclusive of any requirements or guidelines regarding proper ingress or egress into trucks or trailers. These items are provided only as an added feature for installers to help simplify the meeting of possible ingress or egress requirements. As there are many variables in truck sizes and shapes, it is the installers responsibility to determine proper ingress and egress requirements, such as steps, hand grips, grab bars, etc. for each vehicle receiving an Anthony liftgate.

23. Make a final operation check:

- Make sure the platform will travel through a complete cycle, up and down, smoothly and freely, with the platform completely open.
 - Make sure the platform will fold and tuck under the truck in a stored position and latch. The liftgate must fold smoothly and freely.
 - Make sure hydraulic hose fittings are tight and the hydraulic hose does not rub against the liftgate or other parts while cycling up or down, or being opened or closed. Adjust as necessary by loosening fittings and adjusting the position of the hose(s). Retighten fittings.
24. Install lights or other electrical components, if needed.
25. Install grab bars or hand rails, as may be necessary. Also, install license plate holder, as necessary.
26. Attach all decals, as shown in section "6. Decals" on page 37.
27. Complete the items in section "4.10 Final Inspection Checklist" on page 30.

4.7 Battery Connection

There are three methods connect the battery. Only one of the following methods is required to complete the wiring installation.

- Direct Battery Connection (not recommended)
- Cut-Off Solenoid Connection
- Cut-Off Switch Connection

WARNING



PERSONAL INJURY HAZARD

Never secure the power cable to anything which allows it to contact sharp edges, other wiring, the fuel tank, fuel lines, brake lines, air lines, exhaust system, or any other object that could cause the power cable to wear or be damaged. A cut battery cable can cause sparks resulting in loss of vehicle control, serious injury, or even death.

Anthony Liftgates strongly recommends the installation of a power cut-off solenoid or cab cut-off switch. Not cutting off power to the liftgate when unattended can result in serious injury or death to unauthorized users or others near the liftgate.

The liftgate must be properly grounded. A ground wire, the same gauge or larger as the liftgate power cable, must be connected from the negative post of the battery or batteries to the truck's frame. Some trucks may have a properly sized ground wire from the battery to the frame and would require no change. If, however, there is no ground wire or it is undersize, add the correctly sized ground wire.

If this warning is not followed, damage to the truck chassis may occur. Improper grounding can cause the electrical current to travel through brake lines, steel braided power steering hoses, or other chassis wiring causing failure to these components! Failure of these components could result in loss of vehicle control.

4.7.1 Direct Battery Connection (not recommended)

NOTICE

Using the standard wiring hookup is not recommended because it does not cut off power to the liftgate when the truck is left unattended. A cut-off switch or cut-off solenoid will disable the use of the liftgate when the truck is not in use.

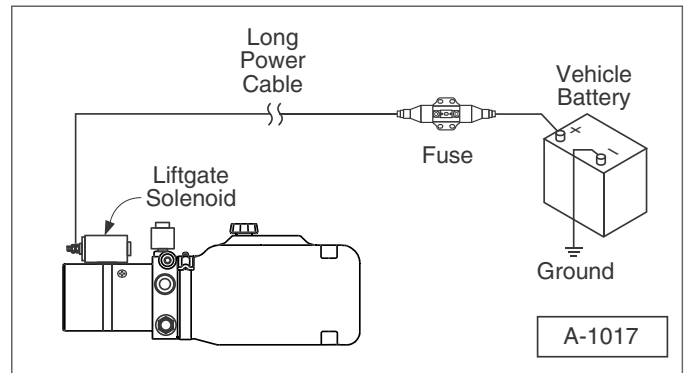

Direct battery connection (not recommended).

- Position the fuse assembly near the battery so the short cable end will reach the positive terminal.
- Attach the fuse holder to the truck body long sill using either method shown in "4.9 Attaching the Power Cable to Truck Frame" on page 29.
- Run the long end of the power cable from the fuse to the motor solenoid. If the power cable is longer than required, cut it to the desired length and attach a cable lug according to instructions listed below.



Connect power cable to motor solenoid.

- Connect the power cable to the motor solenoid. Make sure the power cable is connected to the correct motor solenoid post (one not connected to the motor housing with a metal strap or wire cable).

- e. Connect the short end of the power cable to the positive post of the battery.
- f. The power unit should now be operational.
- g. Coat all terminal ends, studs, and nuts with a Teflon lubricant, grease, or other electrical connection sealant to prevent corrosion.

Note: Do not apply undercoating to power cable or fuse holder! The power cable should be clean near the fuse holder to ensure easy removal of the rubber boot seals if fuse needs to be replaced. For fuse replacement, see the instructions in the Maintenance section of this manual.

4.7.2 Cut-Off Solenoid Connection

The installation of a cut-off solenoid is a recommended option, by Anthony Liftgates, for all 12 Volt electric liftgates. Installing a cut-off solenoid will help to prevent accidental or unauthorized use of the liftgate.

The optional A-133036 Cut-Off Solenoid Kit can be used in any truck, but is essential for tilt cab applications because it requires only a light weight wire running to the cab—not a large cable as required by the cut-off switch.

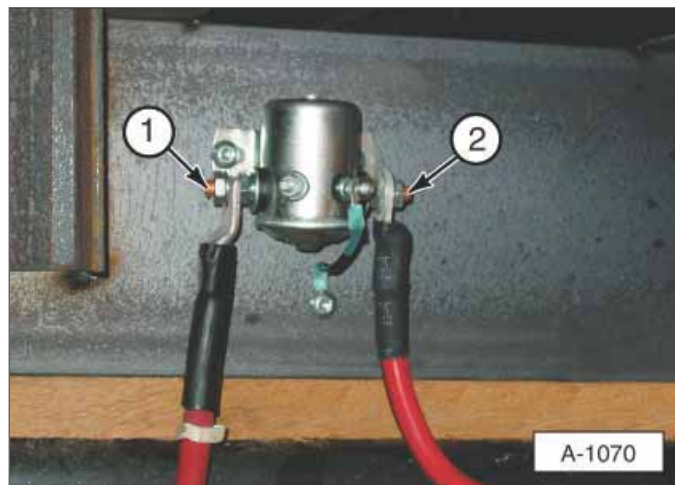
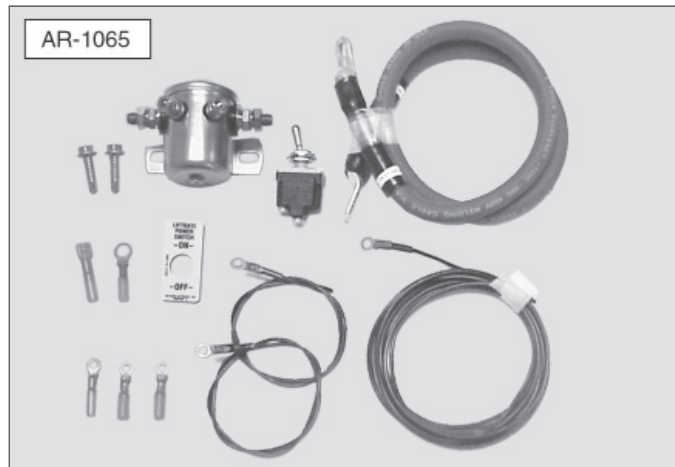

Cut-off solenoid installed between battery and fuse assembly. (1) Short cable, part of solenoid kit. (2) Short end of power cable leading to fuse.

Follow the installation directions on the Installation Instruction sheet that comes with the kit.

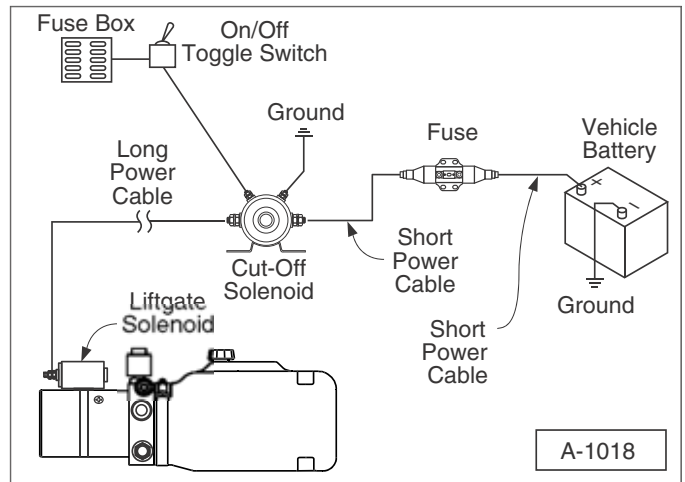

Wiring diagram with cut-off solenoid.

4.7.3 Cut-Off Switch Connection

The installation of a cut-off switch is also a recommended option, by Anthony Liftgates, for all 12 Volt electric liftgates. Installing a cut-off switch will help to prevent accidental or unauthorized use of the liftgate.

Follow the installation directions on the Installation Instruction sheet that comes with the kit.



Cut-off switch mounted in cab of truck.

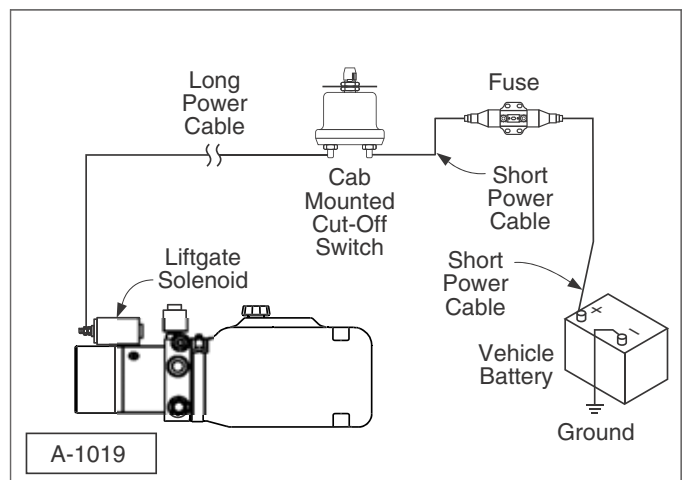

Wiring diagram with cab cut-off switch.

4.8 Cable Lug Installation

1. Strip insulation one inch back from the end of the cable to expose the copper wire.

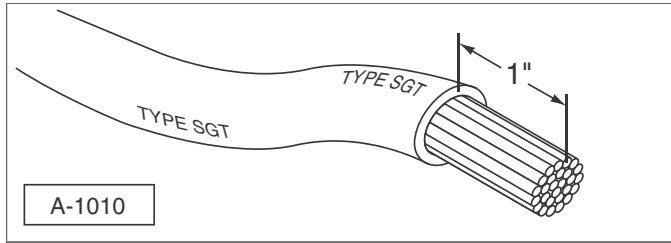

2. Position the cable lug on the exposed wire, as shown. Crimp the cable lug using a cable crimping tool (hydraulic or manual).

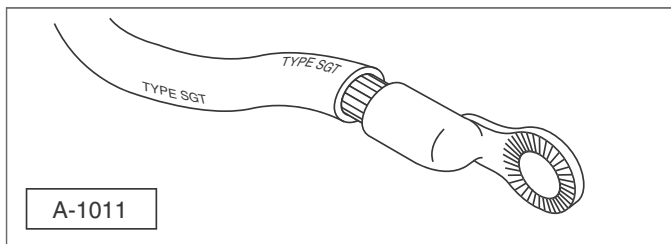

NOTICE

Proper wire connections are crucial to the life of the liftgate's power unit. **DO NOT** crimp (smash) the cable lug with a hammer to secure it to the cable. Poor connections can result in low voltage, and any attempt to operate below the minimum required voltage could cause system failure.

3. Use the supplied heat shrink tube to insulate the new connection. Heat the shrink tubing using a heat gun or propane torch until it shrinks around the cable insulation and cable lug, leaving only the mounting hole exposed. Do not overheat the heat shrink tubing.

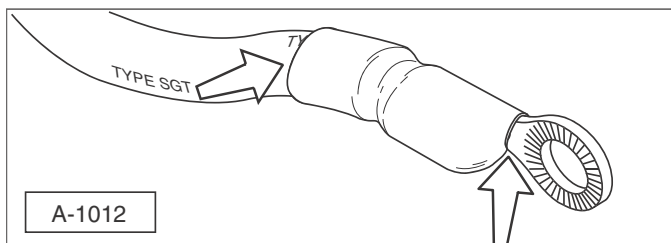

4.9 Attaching the Power Cable to Truck Frame

There are several options for attaching the power cable with the plastic fuse assembly. It can be fastened using plastic tie wraps or wire clips. The fuse assembly can also be bolted directly onto the body long sill, if desired.

4.9.1 Clip or Tie Wrap Installation Method

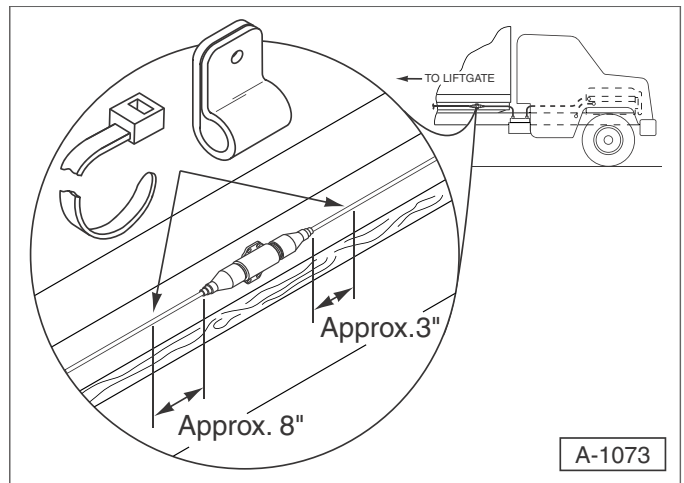

1. Fasten the power cable to the truck body. Locate one fastener (battery side) within 3 inches of the end of the fuse assembly. Locate the other fastener (power unit side) within 8 inches of the fuse assembly.
2. Use of this method does not require the fuse assembly to be attached to the long sill.

4.9.2 Bolt-On Method

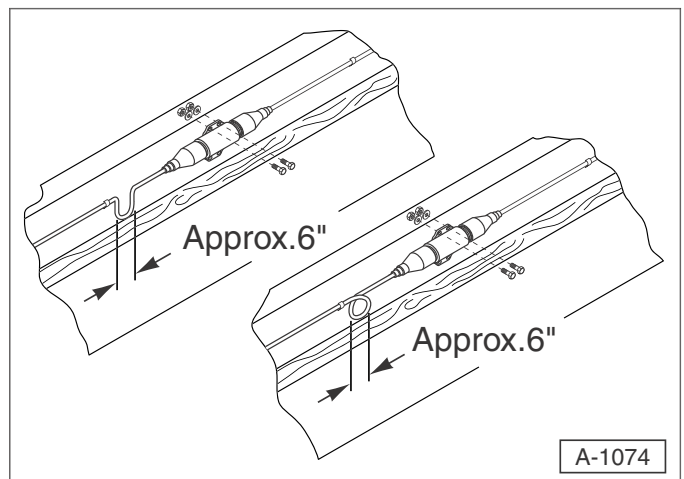

1. Attach the fuse holder to the truck body long sill using #10 or #12 self-tapping screws or bolts, washers, and self-locking nuts.
2. Fasten the power cable, as needed, to properly hold it in place.
3. Using this method requires an extra length of cable on one side of the fuse assembly to permit removal of the fuse.

4.10 Final Inspection Checklist

SAFETY INSTRUCTIONS



Do not use the liftgate if any of the items in the Final Inspection Checklist are not checked and verified. If you have any questions, contact your nearest Anthony distributor, or the Anthony Liftgates main office.

- Check all welds to make sure they are done properly.
- Make sure all pins are in place and held with proper retainers.
- Make sure the power unit reservoir is filled with Dexron VI, Dexron III or Hyken Glacial Blue.

Gravity down models - With the platform on the ground, the oil level should be within 1/2 inch of the top of the reservoir.

Power down models - Place liftgate in the fully raised, the oil level should be within 1/2 inch of the top of the reservoir.

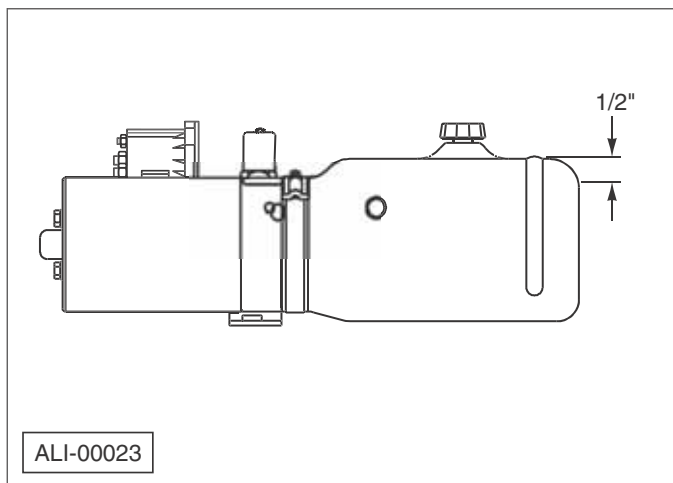

NOTICE

Use only Dexron VI, Dexron III, or Hyken Glacial Blue hydraulic fluid in the power unit reservoir. For cold weather operation, we recommend Hyken Glacial Blue. If an emergency situation occurs, any anti-wear hydraulic fluid can be used, but the system should be flushed and the fluid changed as soon as reasonably possible. Hydraulic fluids should not be mixed due to possible compatibility problems.

The recommended fluids are compatible and may be mixed, however, the cold weather operating characteristics of Hyken Glacial Blue will be adversely affected.

DO NOT thin hydraulic fluid with brake fluid, and DO NOT use brake fluid in place of hydraulic fluid.

- Install cover on power unit box. Make sure it is secured with a padlock or lock pin (customer supplied).
- Operate the liftgate through its entire operational cycle (Up, Down) several times. Make sure the liftgate operates evenly, freely, and smoothly throughout the entire operating range and that there is no unusual noise or vibration while operating the liftgate.
- Make sure the latch works correctly.
- Make sure all decals are in place and legible.
- Make sure license plate bracket is properly installed, as required by law.
- Make sure lights are installed and operating properly, per FMVS 108.
- Make sure reflectors are re-installed, if any.
- Make sure grab handles and other ingress/egress items are properly installed as may be necessary.
- Make sure the optional cab cut-off switch or power cut-off solenoid is installed.
- Put Installation, Operation, and Maintenance manual and Parts manual in the vehicle.

5. Optional Component Installation Procedures

5.1 Bolt-On Floor Extension

Use the following procedure to install the bolt-on floor extension kit, ATU-1446.

1. If necessary, drill mating holes into the truck frame to align with the holes in the floor extension.

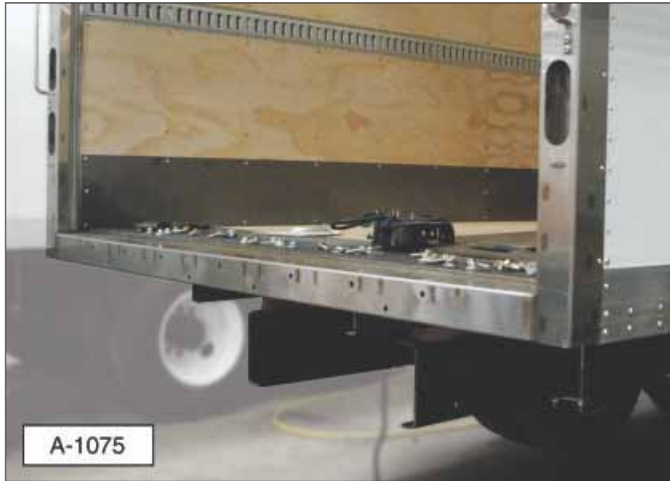

2. Center the floor extension on the truck body. Install the flanged bolts through the extension and truck frame with the bolt heads facing the rear of the truck. Install the flanged nuts.



Note: In some applications, two fender washers must be installed on each of the bottom bolts to keep the extension level and parallel with the bed of the truck.



3. The floor extension has a natural bow in it and must be straightened as it is installed. Tighten the nuts from the center out, keeping the extension flush with the bed of the truck.



4. Install both step bumpers.



6. Weld or bolt the top of the side gussets to the truck body frame.

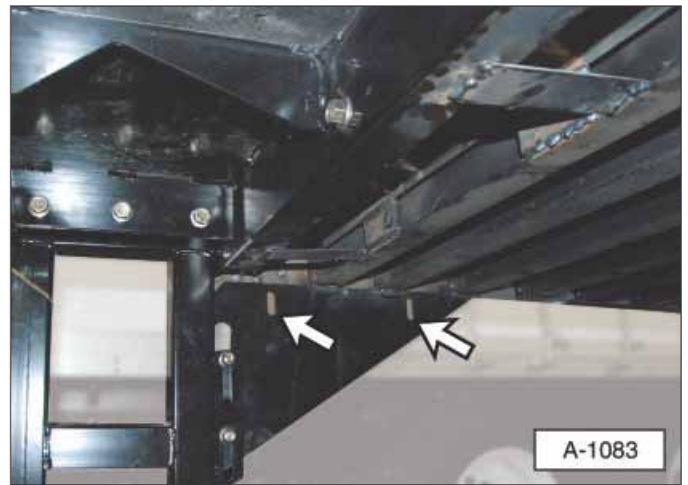

7. Make sure all bolts are tightened to standard torque.

8. Continue with the standard tuckunder installation procedure "4.6 Installation Procedure" on page 18.

5. Bolt the side gusset onto each of the step bumpers.

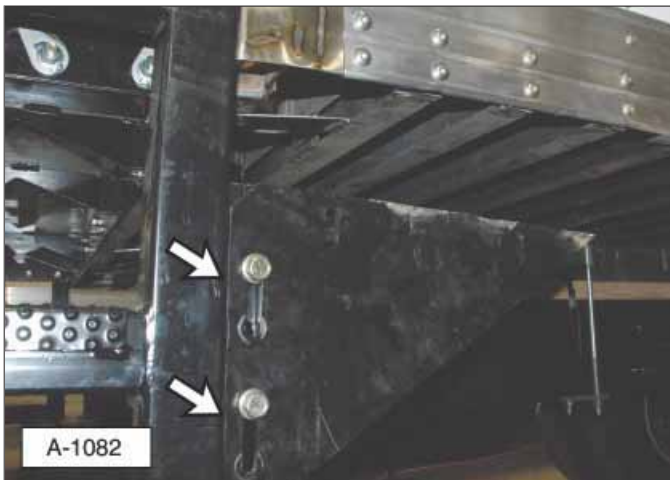

5.2 Pintle Hook Bracket Installation

These installation instructions are for the 5 Ton & 12 Ton pintle hook brackets, ATU-669 & ATU-670.

Note: The 12 Ton pintle hook bracket, ATU-670 can only be used on ATU & AST series liftgates with a lift capacity of 2500 pounds or greater.

Note: The pintle hook bracket installation requires a minimum bed height of 42", with a maximum stack height (top of floor to underside of chassis frame) of 19". This will provide adequate clearance between the pintle hook and the ground when liftgate is lowered.

The approximate hook height is 24" less than the truck bed height.

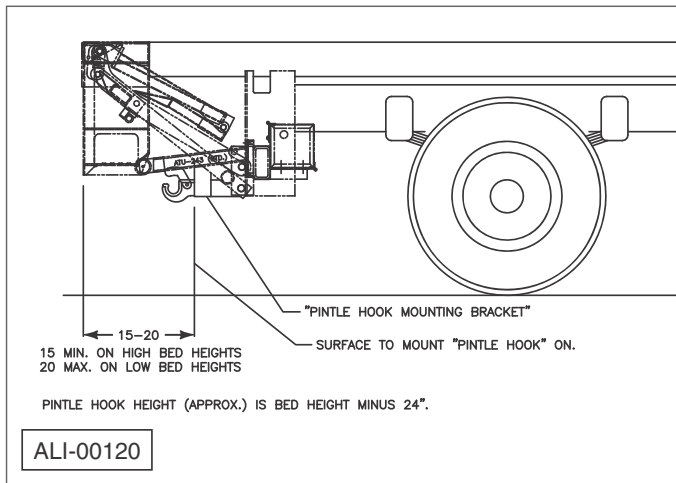

1. Lower the liftgate to the ground and unfold the platform. Support the main section of the platform using wood blocks or similar.

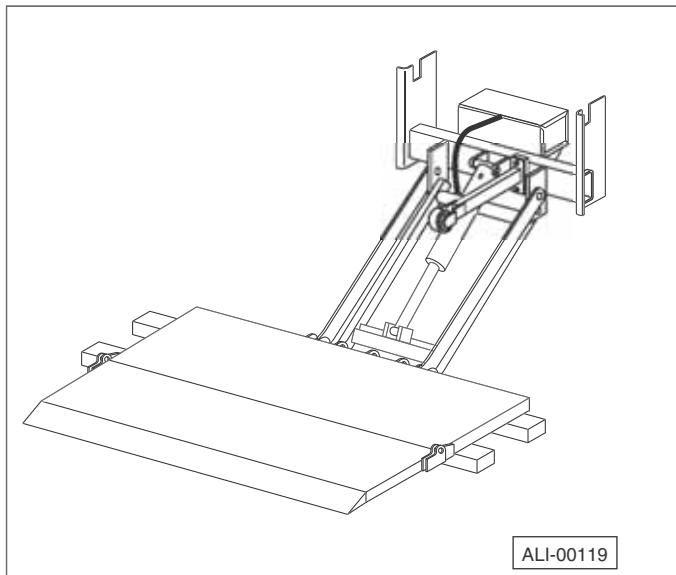

2. Loosen the setscrew in the end of each liftframe arm. Remove the two cotter pins in the liftframe pin. Remove the liftframe pin (ATU-111, 1-1/4" dia. pin) by driving it to one side.

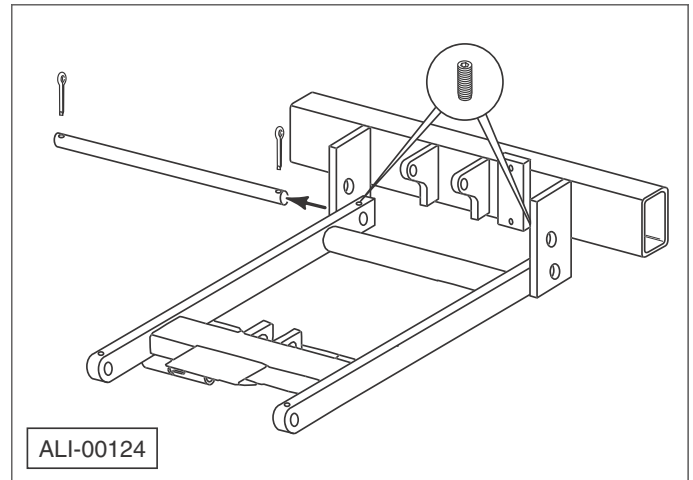

3. Lift the pintle hook bracket into place as shown. Drive the liftframe pin back through the adapter frame plate, liftframe, pintle hook bracket, and reinforcement tube (if required).

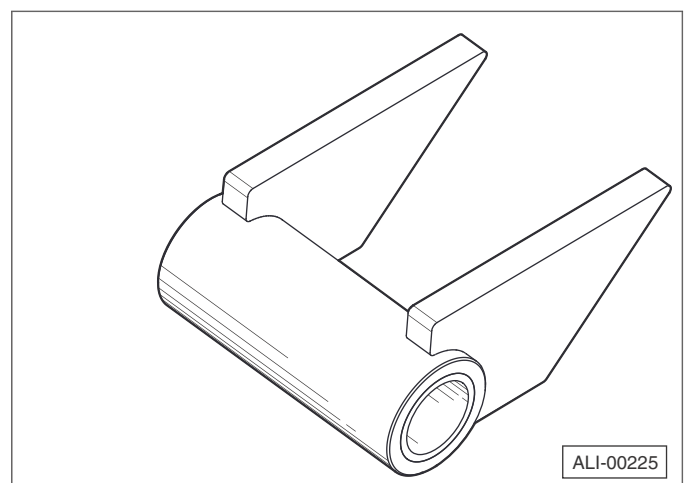
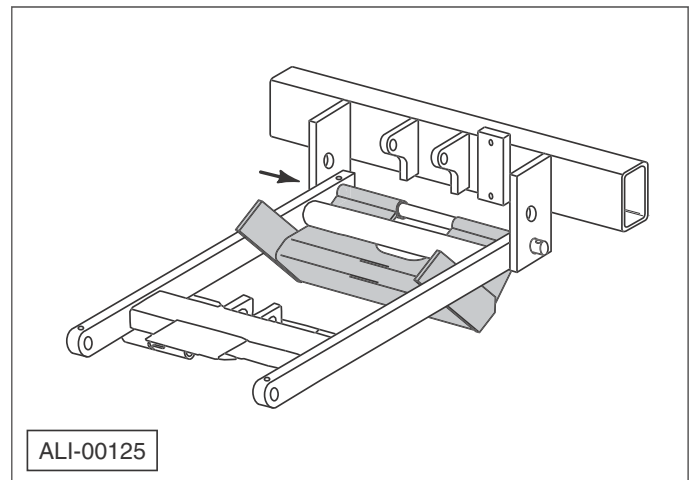

Reinforcement tube ATU-667 required for applications over 5 tons.

- For pintle hook applications above 5 tons, install the reinforcement tube as shown in the diagram. It must be positioned between the pintle hook bracket bushings, and added while re-installing liftframe pin described above. Weld the reinforcement tube to the bottom of the adapter frame tube as shown.

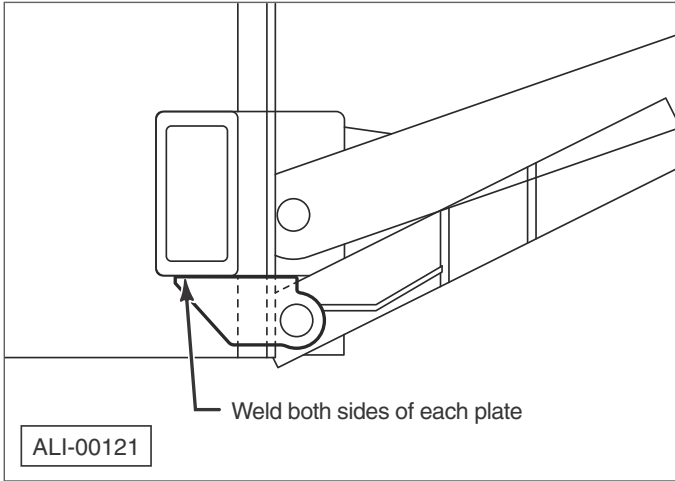

- Fold the platform and raise the liftgate.
- Rotate pintle hook bracket upwards until the vertical bars of pintle hook bracket are between the lifframe arms as shown, and the pintle hook bracket is in the desired, final (in-transit) position. Weld the vertical bars of the bracket to the lifframe as shown. Remove any excess length of the vertical bars to prevent interference with the tucked under platform.

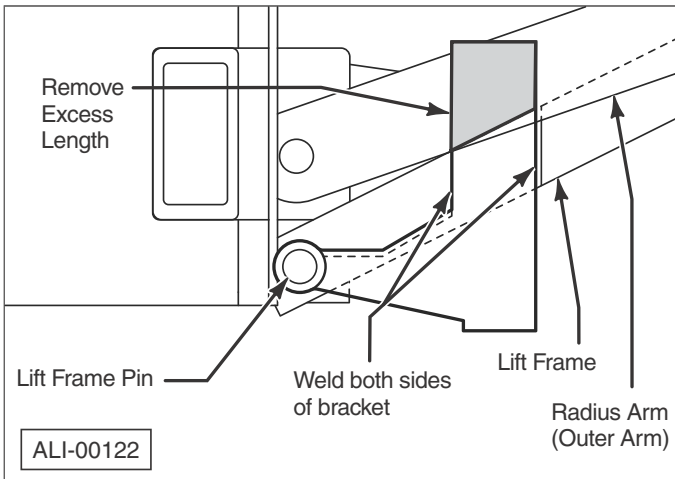

Note: Check the OEM vehicle manual for any special requirements prior to welding on the truck. If required, disconnect the battery cable before welding.

- Secure the lifframe and pin by replacing the two cotter pins, and re-tighten the set screw in the end of each lifframe arm. Tighten the screws in the pintle hook bracket against the lifframe pin.

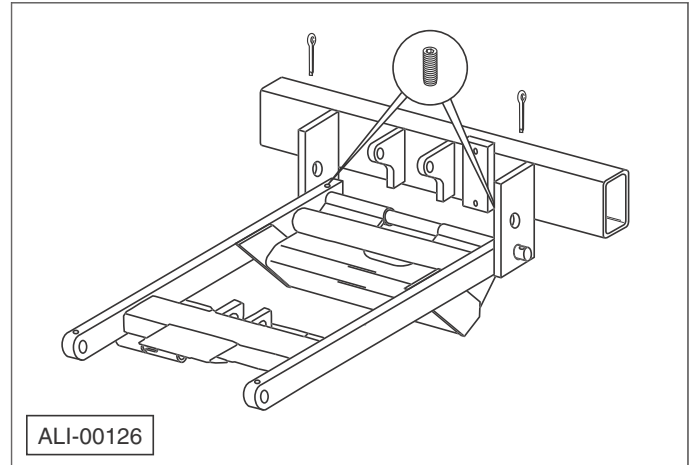

- For pintle hook applications above 5 tons, reinforce the liftgate mounting plates by adding two gussets as shown. Weld ATU-652 gussets to the front edge of the mounting plates and the bottom of the chassis frame rails (both sides). It is permissible to overlap the chassis frame rails slightly for a better welding condition.

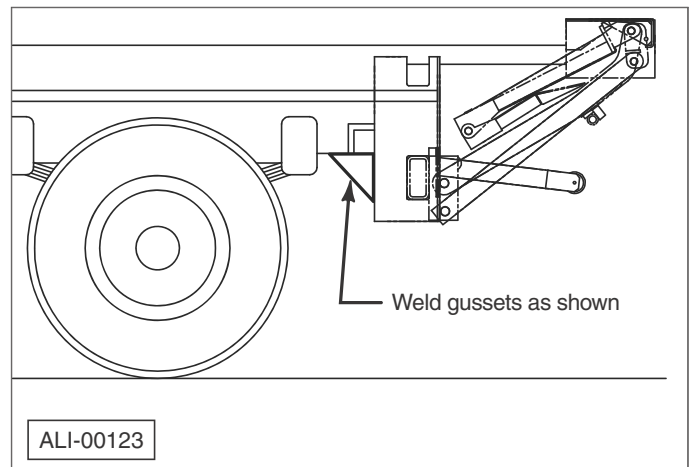

- Bolt the pintle hook to the bracket through the four holes provided.

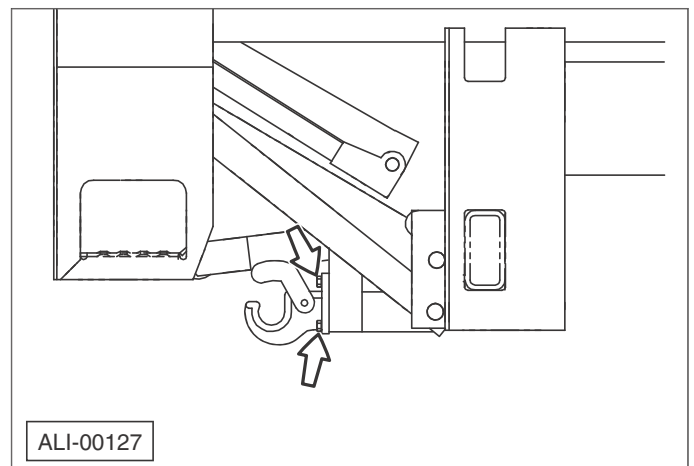

10. Attach safety chain loops (not supplied) to the bracket. Attach the trailer wiring harness socket (not supplied) in the location desired.

WARNING

 **Separation Hazard**
The sudden jerk that occurs when a trailer falls away from a towing unit places tremendous tensile and shear stress on the safety chains, hooks, and attachment points such as bolts or welds. At a minimum, the breaking strength of the safety chain, safety chain hooks, and their attachment points must be equal to the weight of the load the truck is towing, to avoid injury to others.

11. Paint all welded areas before completing installation.

NOTICE

Depending on the trailers being towed with this device, it may be necessary to relocate the liftgate's wheel arm. This is to prevent damage to the wheel arm from contacting the trailer tongue when turning corners. The wheel arm can be repositioned near the end of the liftgate's adapter frame tube (6" x 3" rectangle tube). Be certain to mount it in line with one of the channels on the bottom of the platform when folded.

5.2.1 Pintle Hook Bracket Maintenance

Before each use, inspect the pintle hook, bracket, fasteners and attachment points.

1. Check for loose or broken pintle hook bolts, if found don't use until tightened or replaced.
2. Check that the liftframe pin (1-1/4" dia. pin) is secured by all fasteners, liftframe, setscrews, pintle hook set screws & cotter pins. If missing or loose, replace and/or tighten.
3. Check for broken welds. If any welds are broken, DO NOT use until they have been repaired or replaced.

5.2.2 Towing Safety

WARNING

Failure to comply with the following safety instructions could result in serious injury or death to the operator and others sharing the road.

 **Vehicle Owner/Operator Manual**
Always refer to the towing vehicle owner's manual, trailer towing section, to determine the vehicle's towing capacity and to ensure compatibility and maximum safety.

 **Hitch Rating**
Make sure the coupling device or hitch on the towing vehicle is rated greater than the trailer's "gross vehicle weight rating" (GVWR).

 **Inspect Hitch and Coupling**
Inspect the coupling device for wear or damage. Make sure the hitch and coupling are compatible. DO NOT tow the trailer using a defective hitch or coupling.

 **Hitch Attachment**
Be sure the trailer is securely attached to the tow vehicle and in good operating condition before using.

 **Crisscross Safety Chains**
Connect and crisscross the chains under the hitch to support the hitch should an unplanned separation occur. Make sure the chains are not touching the road, but have enough slack to make turns.

 **Brakes**
Make sure the brakes are operating properly. If equipped with a breakaway brake system, attach the breakaway cable to the rear of the towing vehicle. Do not attach the cable to the trailer hitch. Make sure the battery is charged.

 **Tire Pressure**
Check the tires for high/low pressure, cuts, bubbles, damaged rims, or missing lug nuts. Do not use the trailer if any damage is found. Make sure the wheel lug nuts on the tow vehicle and trailer are tightened to the correct torque.

 **Signal Lights**
Make sure the directional and brake lights on the trailer are connected and working properly. Make sure the wiring harness is not touching the road, but is loose enough to make turns without disconnecting or damaging the wires.

 **Maintenance**
Before driving, make sure your vehicle maintenance and trailer maintenance are current. This is very important because towing puts additional stress on the tow vehicle.

5.3 Trailer Sub Frame Installation

When mounting the liftgate to a trailer, it may be necessary to add a sub frame to provide attachment points. A sub frame kit is available from Anthony Liftgates for this purpose.

1. Locate the attachment points. Typical mounting widths for 96" and 102" wide trailers are shown below. In addition, the rear end of the sub frame must be 0" to 12" forward of the rear of the trailer body, and both ends of the sub frame must be on cross members.

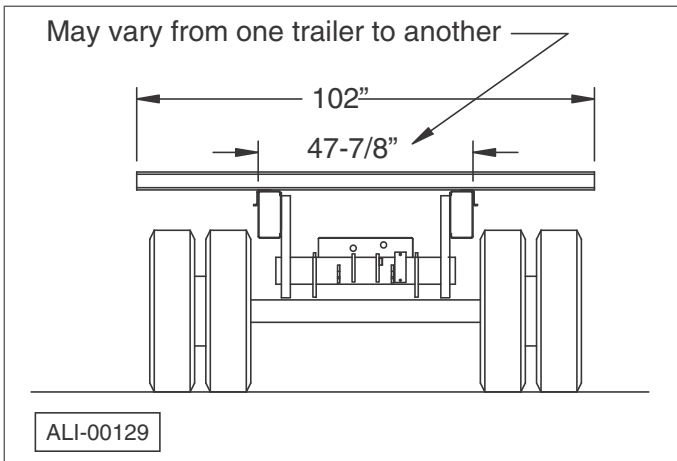
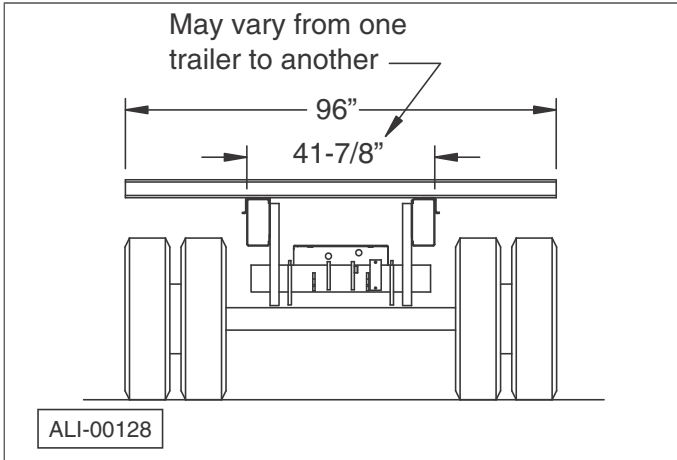

2. The end of the sub frame must be 0" to 12" forward of the rear of the trailer body, and must be on a cross member.

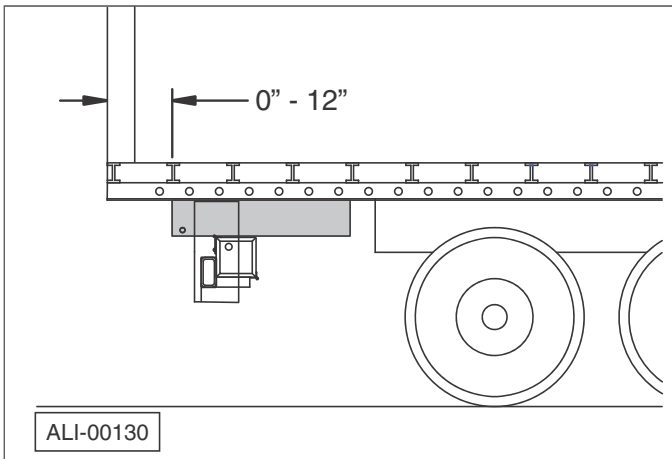

3. Weld the sub frame to the trailer cross members as shown. Both ends of the sub frame must be on cross members.

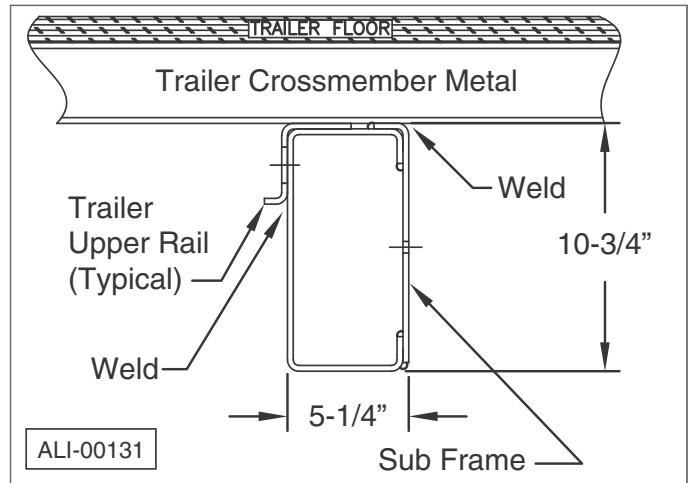

4. Mount the liftgate to the sub frame following the procedure in "4. Installation Section" on page 13.

Note: Standard ATU-57 mounting plates are used. The 90° bent flange has to face to the inside to allow for proper welding.

5. If necessary, notch the sub frame as shown for proper folding clearance.

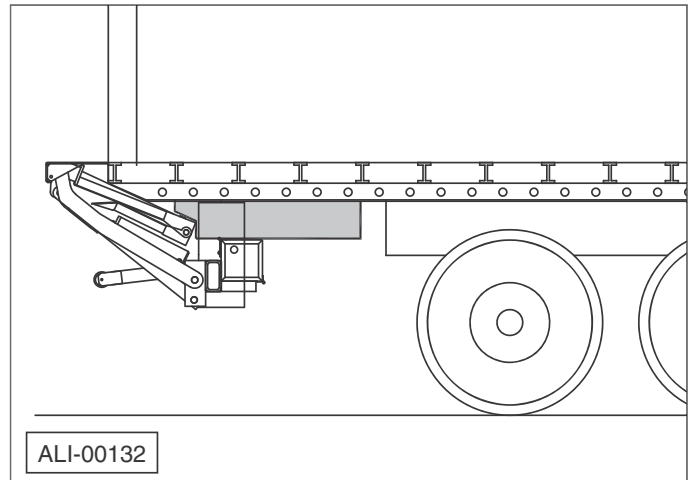

6. Decals

6.1 Decal Locations

SAFETY INSTRUCTIONS



To prevent possible injuries due to improper operation, make sure all decals are attached to the liftgate and/or truck and are legible at all times.

Safety decals provide a vital role in helping to reduce injuries and/or death. To ensure the greatest level of safety, all decals must be in place and legible at all times. Remember, it is the users' responsibility to maintain these decals.

For a complete part number list of the decals used on the Tuckunder liftgates, refer to the Decals section in the Online Parts Manual for AXM, AST, and ATU Tuckunder Liftgates.

For replacement decals contact:

Anthony Liftgates, Inc.
 1037 West Howard Street
 Pontiac, Illinois 61764
 (815) 842-3383 or 800-482-0003
www.anthonyliftgates.com

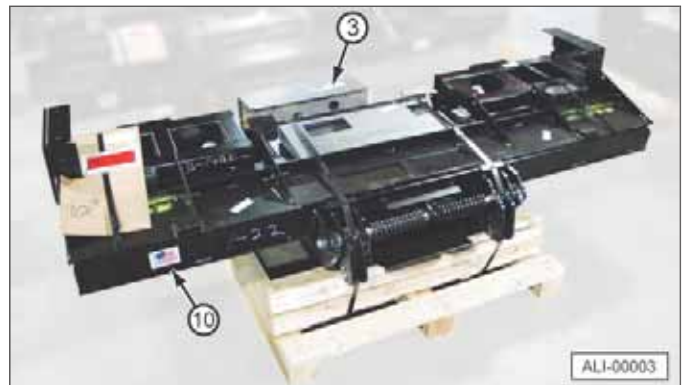

Factory installed decals.

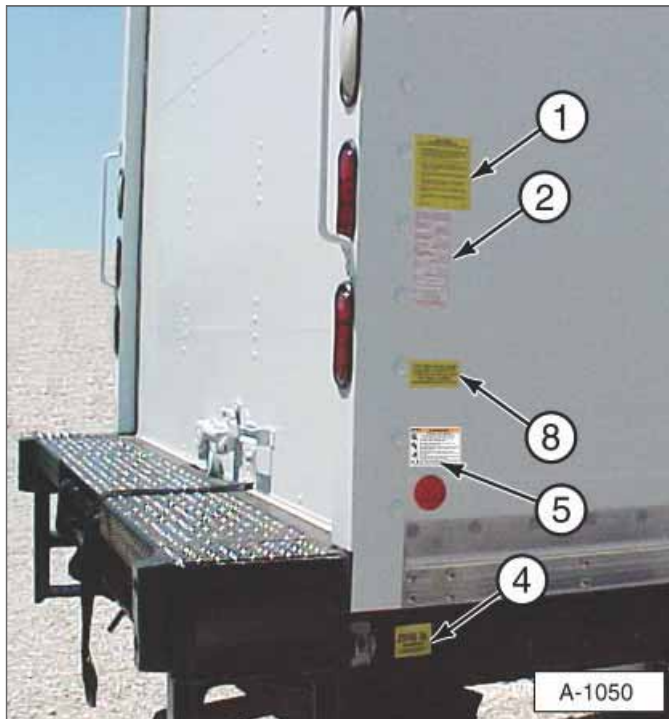

Customer installed decals.

Decal Kits		
Item	Part no.	Description
1	A-131054C	Urgent Warning Decal
2	A-131055C	Operating Instructions Decal
3	A-131057C	Weld Warning Decal
4	A-131064C	1500 lbs. Maximum Capacity Decal
	A-131059C	1800 lbs. Maximum Capacity Decal
	A-131060C	2000 lbs. Maximum Capacity Decal
	A-131061C	2500 lbs. Maximum Capacity Decal
	A-131062C	3000 lbs. Maximum Capacity Decal
	A-131063C	3500 lbs. Maximum Capacity Decal
5	A-131115	Warning Personal Injury Hazard Decal
6	A-131050C	Anthony Hydraulic Liftgate Label Decal
7	A-131056C	Disengage Latch Before Using Liftgate
8	A-131053C	After Using Liftgate, Secure Latch Decal
9	A-131058C	Liftgate Fuse Changing Procedure
10	A-150601	Flag — Made in the USA

6.2 Decal Illustrations

1.

URGENT WARNING

ELEVATING GATE INSTRUCTIONS

Before Operating Lift, Be Sure You Understand the Following.

1. Improper operation of this lift can result in serious personal injury. Do not operate unless you have been properly instructed and have read and are familiar with the operating instructions. If you do not have a copy of the instructions, please obtain one from your employer, distributor, or lessor, as appropriate, before you attempt to operate the lift.
2. Be certain the vehicle is properly and securely braked before using the lift.
3. Always inspect this lift for maintenance or damage before using it. If there are signs of improper maintenance, damage to vital parts, or slippery platform surface, do not use the lift. Do not attempt your own repairs unless you are specifically trained.
4. Do not overload. See mfg. literature and/or rating label on the unit for the rated load. Remember that this limit applies to both raising and lowering operations.
5. Each load should be placed in a stable position within the edges of the platform, as near as possible to the center of the platform, side to side, and as close as possible to the truck sill.
6. Never stand in or move through, or allow anyone else to stand in or move through the area in which the lift may operate, or into which an upset load might fall.
7. This is not a passenger lift. This liftgate is intended for loading and unloading of cargo only. Do not use this liftgate for anything but its intended use.

ADVERTENCIA URGENTE

INSTRUCCIONES PARA LA COMPUERTA ELEVADORA

Antes de Operar el Elevador, Asegúrese de Entender lo Siguiente.

1. El uso no apropiado de este elevador puede ocasionar serias lesiones personales. No opere el elevador al menos que usted haya sido instruido apropiadamente para hacerlo y haya leído y se haya familiarizado con las instrucciones de operación. Si usted no tiene una copia de las instrucciones, solicite una copia a quién corresponda (su patrón, distribuidor o arrendatario), antes de intentar operar el elevador.
2. Antes de usar el elevador, cerciórese de que el vehículo esté seguro y apropiadamente frenado.
3. Antes de usar este elevador, siempre inspeccione su estado. Si hay señales de mal mantenimiento, daños en partes vitales, o la superficie de la plataforma está resbalosa, no use el elevador. No intente hacer reparaciones en la plataforma a no ser que usted haya sido entrenado específicamente para ello.
4. No sobrecargue. Refiérase a la literatura del fabricante y/o observe la capacidad de carga nominal en la etiqueta de capacidad colocada sobre la unidad. Recuerde que este límite aplica tanto a las operaciones de levante como a las de bajada.
5. La carga debe ser colocada en una posición estable dentro de los bordes de la plataforma, tan cerca al centro lateral de la plataforma como sea posible, y lo más cerca al umbral del camión que se pueda.
6. Nunca se debe parar ni mover, ni dejar que nadie se pare o mueva en el área en que se va a operar el elevador, o en el área en la que una carga mal balanceada pueda caerse.
7. Este no es un elevador para pasajeros. Este elevador es únicamente para el levante y bajada de carga. No use este elevador para cualquier otro propósito.

A-131054 05/2010

3.

WELD WARNING!

FOR ALL ANTHONY "SERVICE-FREE" LIFTGATES

When performing welding during installation, service, or repair on Anthony "SF" Service-Free liftgates, the actual part being welded must be grounded. Failure to follow this instruction can cause the welding ground to travel through the high pressure hydraulic hose as the source of ground, thus causing damage to the hose from the powerful electric current. The resulting damage to the hose may or may not be visible and can cause unexpected, catastrophic failure of the lift. If you have any questions, please contact Anthony Liftgates, Inc., Pontiac, Illinois.
(800-482-0003)

¡ADVERTENCIA ANTES DE SOLDAR!

PARA TODOS LOS ELEVADORES ANTHONY "SERVICE-FREE"

Cuando se tenga que soldar durante instalación, servicio o reparación de un elevador Anthony "SF" Service-Free, la pieza que se está soldando debe estar a tierra. El no seguir esta instrucción causará que la tierra de la máquina soldadora viaje a través de la manguera hidráulica de alta presión hasta la fuente de tierra. La intensa corriente eléctrica dañará la manguera. El daño resultante puede ser visible o invisible, y puede causar una inesperada falla catastrófica del elevador. Si usted tiene alguna pregunta al respecto, por favor contacte Anthony Liftgates, Inc., Pontiac, Illinois, USA.
(800-482-0003)

A-131057 05/2010

2.

ANTHONY ATU, AST, ASTL, AXM, & LB LIFTGATE

OPERATING INSTRUCTIONS / INSTRUCCIONES DE MANEJO

<p style="font-size: 0.7em;">1 UNLATCH LIFTGATE BY TWISTING, THEN SLIDING "LATCH PIN" IN DIRECTION OF ARROW.</p>		<p style="font-size: 0.7em;">DESASEGURE EL ELEVADOR GIRANDO Y TIRANDO DEL PASADOR EN LA DIRECCION DE LA FLECHA.</p>
<p style="font-size: 0.7em;">2 LOWER PLATFORM BY PUSHING CONTROL SWITCH TO "DOWN" POSITION. <small>Platform will begin to open as it lowers.</small></p>		<p style="font-size: 0.7em;">BAJE LA PLATAFORMA EMPUJANDO EL CONTROL HACIA LA POSICION "DOWN". <small>La plataforma empezará a abrirse a medida que baja.</small></p>
<p style="font-size: 0.7em;">3 UNFOLD PLATFORM BY PULLING PLATFORM HANDLE OUTWARD AND TOWARD GROUND.</p>		<p style="font-size: 0.7em;">DESDOBLE LA PLATAFORMA TIRANDO DE LA MANUJA HACIA AFUERA Y HACIA EL PISO.</p>
<p style="font-size: 0.7em;">4 UNFOLD "FLIP" SECTION.</p>		<p style="font-size: 0.7em;">DESDOBLE LA SECCION PLEGADA "FLIP"</p>
<p style="font-size: 0.7em;">5 FLIP SWITCH "UP" TO RAISE PLATFORM OR FLIP SWITCH "DOWN" TO LOWER PLATFORM</p>		<p style="font-size: 0.7em;">MANTENGA EL CONTROL EN "UP" PARA LEVANTAR LA PLATAFORMA O "DOWN" PARA BAJARLA</p>
<p style="font-size: 0.7em;">6 TO TUCK UNIT AFTER USE, LOWER PLATFORM TO GROUND AND REVERSE STEPS</p>		<p style="font-size: 0.7em;">PARA GUARDAR LA UNIDAD DESPUES DE USARLA, BAJELA AL PISO E INVIERTA LOS PASOS</p>

ANTHONY LIFTGATES, INC.
1037 WEST HOWARD ST. PONTIAC, IL 61764
800-482-0003

A-131055 05/2010

4.

MAXIMUM CAPACITY

1500 lb.

650 kg.

CAPACIDAD MÁXIMA

A-131064 05/2010

CAUTION

Make sure the proper "maximum capacity" decal goes on the appropriate liftgate. For example, A-131062 "3000 lb. Maximum Capacity" decal goes on MTU-GLR 3000 models only. Do not put a higher rated decal (4000 pound) on a smaller liftgate; this could result in liftgate damage or possibly personal injury.

5.

ANTHONY LIFTGATES, INC.

WARNING

PERSONAL INJURY HAZARD

	<p style="font-size: 0.7em;">Operation may require user to stand on platform. To prevent injury or death of operators or bystanders:</p>
	<ul style="list-style-type: none"> • Read and follow operator/owner manual for safety, operation, inspection, and maintenance instructions.
	<ul style="list-style-type: none"> • Do not place unstable or unsafe loads on platform. • Do not allow loads to extend over edge of platform.
	<ul style="list-style-type: none"> • Do not exceed capacity or use liftgate for anything other than intended purpose.
	<ul style="list-style-type: none"> • Be aware of surroundings when operating liftgate. • Do not allow body parts to contact moving components.
	<ul style="list-style-type: none"> • Ensure footing is stable and stand away from edge before raising or lowering platform.
	<ul style="list-style-type: none"> • Owner/operators must properly maintain liftgate.

A-131115



7. **Note:**
**DISENGAGE "LATCH"
 BEFORE ATTEMPTING
 TO USE LIFTGATE.**

**ENGAGE "LATCH"
 AFTER
 USING LIFTGATE.**

Nota:
**REMUEVA EL "PESTILLO"
 ANTES DE INTENTAR
 USAR EL ELEVADOR.**

**COLOQUE EL "PESTILLO"
 DESPUES DE
 USAR EL ELEVADOR.**

A-131056 05/2010

8. **AFTER USING LIFTGATE, SECURE
 LATCH, AND IF EQUIPPED WITH
 POWER CUT-OFF SWITCH, TURN
 OFF POWER TO PREVENT
 UNAUTHORIZED USE OF LIFTGATE.**

**DESPUES DE USAR EL ELEVADOR,
 ASEGURE EL PESTILLO, Y SI
 EXISTE UN INTERRUPTOR DE
 CORRIENTE, ACCIONELO PARA
 EVITAR EL USO NO AUTORIZADO
 DEL ELEVADOR.**

A-131053 05/2010

9. View fuse through clear fuse holder, if blown, replace as follows:
Liftgate fuse changing procedure.

Warning! To avoid injury, disconnect the liftgates power from the battery(ies) before replacing the fuse, or before disassembling the fuse holder. Do not ignore this warning or an "arc" can occur and personal injury or property damage could result.

1. Pull back rubber boots from fuse holder.
2. Unscrew the fuse holder ends from the fuse holder body and pull apart.
3. Slide the fuse holder body one direction (left or right) to expose the blown fuse.
4. Loosen screw from each end of fuse, remove and replace fuse. Tighten screws.
5. Re-assemble in reverse order. Be sure the rubber boots seal around the fuse holder and cable.
6. Re-connect power after you are certain liftgate area is clear.

Note: Check for spare fuse in liftgate manual packet. If fuses continue to blow, contact a qualified mechanic to remedy the problem.

Observe el fusible a través del portafusible transparente; si está quemado, cámbielo de la manera siguiente:

Procedimiento para cambiar el fusible de la compuerta elevadora.

¡Advertencia! Para evitar lesiones, desconecte la alimentación de la(s) batería(s) de la compuerta elevadora antes de cambiar el fusible, o antes de desarmar el portafusible. No pase por alto esta advertencia ya que puede formarse un arco eléctrico y causar lesiones corporales o daño al equipo.

1. Tire de las fundas de caucho del portafusible hacia atrás.
2. Destornille los extremos del portafusible del cuerpo del mismo y sepárelo.
3. Deslice el cuerpo del portafusible en un sentido (a la izquierda o derecha) para dejar al descubierto el fusible quemado.
4. Afloje el tornillo de cada extremo del fusible, retire y reemplace el fusible. Apriete los tornillos.
5. Vuelva a armar en orden inverso. Verifique que las fundas de caucho sellen bien alrededor del portafusible y cable.
6. Conecte la alimentación después de comprobar que el área de la compuerta elevadora está despejada.

Nota: Busque el fusible de repuesto en el paquete del manual de la compuerta elevadora. Si los fusibles siguen quemándose, comuníquese con un mecánico competente para que solucione el problem.

A-131058

05/2010



7. Operation Section

7.1 General Operating Safety Instructions

WARNING



Crush Hazard

Do not stand in the platform's work area while operating the liftgate. Serious injury or death could result if the load shifts or is unstable on the platform.

CAUTION



Anthony Liftgates recommends not riding the liftgate, however, if the delivery operation requires it, make sure your footing is stable before raising or lowering platform. Always stand away from the edge. When on the ground, always stand clear of liftgate when it is operating.



Always use/set the truck's parking brake before operating the liftgate. Failure to follow this recommendation can result in injury.



Do not place hands or feet in pinch points.



Do not place your feet under the liftgate.

SAFETY INSTRUCTIONS



To prevent possible injuries due to improper operation, make sure all decals are attached to the liftgate and/or truck and are legible at all times.



Proper operating position.

The following is a list of Do's and Don'ts for the operation of the liftgate.

✓ Do's

- ✓ Read and follow warning decals, operating decals, and owners manual.
- ✓ Keep all decals in place and legible and retain the owners manual with the vehicle or all Warranties are void.
- ✓ Make sure the vehicle is properly and securely braked before using the liftgate.
- ✓ Keep yourself clear of all moving parts.
- ✓ Make sure the area in which the platform will open and close is clear before opening, closing, raising, or lowering the platform.
- ✓ Make sure the platform area, including the area in which loads may fall from the platform, is clear before, during, and at all times while operating the liftgate.





- ✓ Always place the load as close to the center of the platform as possible. Also, position the load as close to the center of the truck's rear sill as possible.
- ✓ Only operate the liftgate with the switch controls mounted on the truck body unless an optional handheld remote is installed.
- ✓ Check the fluid level in the hydraulic reservoir monthly. Fill as required with Dexron VI, Dexron III or Hyken Glacial Blue. Change the fluid if it is contaminated or dirty.
- ✓ Visually inspect your liftgate frequently and keep it properly adjusted.
- ✓ Repair any damage to the liftgate to prevent accidents.
- ✓ When placing the liftgate in the storage position (folding), slowly fold the platform until it contacts the wheel arm assembly.
- ✓ Lock the liftgate into the storage position with the latch pin when the liftgate is not in use.

× Don'ts

- × Do not overload the platform. The maximum rated capacity is based on an evenly distributed load on the platform's flat surface.
- × Anthony Liftgates recommends not riding the liftgate. However, if the delivery operation requires it, make sure your footing is stable before raising or lowering, platform. Always stand away from the edge. When on the ground, always stand clear of the liftgate when it is operating.
- × Do not allow children to play around or operate the liftgate.
- × Do not allow the liftgate to be used by persons not familiar with its operation.
- × Do not use the liftgate if it shows signs of abuse or fails to operate freely.
- × Do not allow the motor/pump to run after the liftgate is closed, or in the up position.
- × Do not use brake fluid in the hydraulic reservoir.
- × Do not bounce the platform by pushing and releasing the control switch abruptly.
- × Do not use the liftgate for anything other than its intended use of loading and unloading cargo.
- × Do not operate lift trucks on or over any part of the platform.
- × Do not stand under or place any object under the liftgate work area.

7.2 Operating Instructions

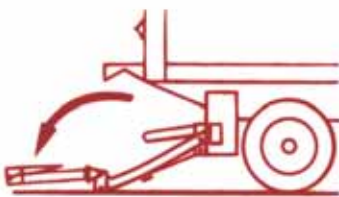
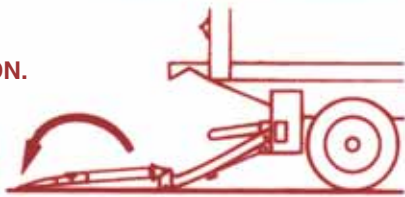
1. Twist and slide the latch pin toward the curbside of the liftgate.
2. Stand clear of the platform and lower the liftgate by pressing "Down" on control switch.
3. Open the platform.
4. Open the flipover ramp.
5. Press the "Up" switch to raise platform or the "Down" switch to lower the platform.
6. To place the liftgate into its storage position after use, reverse Steps 1 2, 3, and 4 from ground level.

ANTHONY ATU, AST, ASTL, AXM, & LB LIFTGATE OPERATING INSTRUCTIONS / INSTRUCCIONES DE MANEJO		
1	<p>UNLATCH LIFTGATE BY TWISTING, THEN SLIDING "LATCH PIN" IN DIRECTION OF ARROW.</p> 	<p>DESASEGURE EL ELEVADOR GIRANDO Y TIRANDO DEL PASADOR EN LA DIRECCION DE LA FLECHA.</p>
2	<p>LOWER PLATFORM BY PUSHING CONTROL SWITCH TO "DOWN" POSITION.</p> <p>Platform will begin to open as it lowers.</p> 	<p>BAJE LA PLATAFORMA EMPUJANDO EL CONTROL HACIA LA POSICION "DOWN".</p> <p>La plataforma empezará a abrirse a medida que baja.</p>
3	<p>UNFOLD PLATFORM BY PULLING PLATFORM HANDLE OUTWARD AND TOWARD GROUND.</p> 	<p>DESDOBLE LA PLATAFORMA TIRANDO DE LA MANIJA HACIA AFUERA Y HACIA EL PISO.</p>
4	<p>UNFOLD "FLIP" SECTION.</p> 	<p>DESDOBLE LA SECCION PLEGADA "FLIP"</p>
5	<p>FLIP SWITCH "UP" TO RAISE PLATFORM -OR- FLIP SWITCH "DOWN" TO LOWER PLATFORM</p> 	<p>MANTENGA EL CONTROL EN "UP" PARA LEVANTAR LA PLATAFORMA -O- "DOWN" PARA BAJARLA</p>
6	<p>TO TUCK UNIT AFTER USE, LOWER PLATFORM TO GROUND AND REVERSE STEPS</p>	<p>PARA GUARDAR LA UNIDAD DESPUES DE USARLA, BAJELA AL PISO E INVIERTA LOS PASOS</p>
<div style="display: flex; justify-content: space-around;"> 1 2 3 4 </div>	<div style="display: flex; justify-content: space-around;"> 1 2 3 4 </div>	
<h1>ANTHONY LIFTGATES, INC.</h1> <p>1037 WEST HOWARD ST. PONTIAC, IL 61764</p> <p>A-131055 800-482-0003 05/2010</p>		

8. Maintenance Section

WARNING



To prevent serious bodily injury, keep sparks, lighted matches, and open flames away from the top of the battery, because battery gas can explode. Always follow all the manufacturers' safety recommendations when working around the truck's battery.



Take precautions to avoid sparks coming into contact with the truck's fuel tank, brake lines, or other flammable components. Sparks can cause an explosion of combustible materials, resulting in serious injury or death.



Never secure the power cable to anything which allows it to contact sharp edges, other wiring, fuel tank, fuel lines, brake lines, air lines, exhaust system, or any other object that could cause the power cable to wear or be damaged. A cut battery cable can cause sparks resulting in loss of vehicle control, serious injury, or even death.



Always weld in a well ventilated area and, if in an enclosed area, vent the fumes to the outside. Breathing welding smoke and paint fumes can cause serious injury.



Always follow all State and Federal health and safety laws and/or local regulations when using an arc welder, mig welder, or cutting torch. Also, follow all manufacturer's safety guidelines. If other people are present during the installation of the liftgate, make sure the welding area is shielded from their view.



To avoid eye injury during welding, always wear a welding helmet with the proper lens to protect your eyes.



To prevent personal injury, clean up any spilled fluids immediately. To avoid tripping, do not leave tools or components laying around in the work area.

8.1 Monthly Inspection

All Anthony Tuckunder Liftgates are "Service-Free" which means they have lubrication-free bushings at the major pivot points.

1. Make sure the liftgate operates freely and smoothly throughout its entire range of movement.
2. Check for damage to the liftgate, such as bent or distorted parts. Check for excessively worn parts.
3. Check for cracked welds which may have resulted from overload or abuse.
4. Check all pins and pivot points. Make sure they are secured with proper retainers. Replace worn bushings and/or pins.

5. Make sure platform is angled upward from truck bed 1/2 to 3/4 inch when raised to bed height. See Platform Adjustment for shimming procedure. "8.3.1 Platform Adjustment (adding shims)" on page 44
6. Make sure all electrical wires, switches, and connections are in good working condition and operate properly.
7. Check for oil leaks in the following areas:
 - a. Hydraulic lift cylinder.
 - b. Hydraulic hoses. Replace the hose if it show signs of leakage or excessive abrasion of the covering.
 - c. Check all hydraulic fittings for damage or leakage. Tighten fittings to stop leaks or replace if damaged.
8. Check reservoir oil level and fill as required with Dexron VI, Dexron III or Hyken Glacial Blue.
 - a. Gravity down models - With the platform on the ground, the oil level should be within 1/2 inch of the top of the reservoir.
 - b. Power down models - Place liftgate in the fully raised position, the oil level should be within 1/2 inch of the top of the reservoir.

NOTICE

Use only Dexron VI, Dexron III, or Hyken Glacial Blue hydraulic fluid in the power unit reservoir. For cold weather operation, we recommend Hyken Glacial Blue. If an emergency situation occurs, any anti-wear hydraulic fluid can be used, but the system should be flushed and the fluid changed as soon as reasonably possible. Hydraulic fluids should not be mixed due to possible compatibility problems.

The recommended fluids are compatible and may be mixed, however, the cold weather operating characteristics of Hyken Glacial Blue will be adversely affected.

DO NOT thin hydraulic fluid with brake fluid, and **DO NOT** use brake fluid in place of hydraulic fluid.

9. Check the fluid level of the vehicle battery. Fill as required.
10. Examine all warning, capacity, and operational decals. If they are not readable, they should be replaced. Decals may be obtained free of charge from Anthony Liftgates, Inc.
11. Oil the roller of the wheel arm and make sure it spins freely.

8.2 Semi-Annual Inspection

In addition to the items requiring monthly inspection, also inspect the condition of the hydraulic fluid.

If the oil in the hydraulic tank is dirty, drain the oil and flush the entire system. Refill the system with the recommended oil outlined in Step 7 of the "Monthly Inspection" section.

8.3 Maintenance and Troubleshooting Procedures

8.3.1 Platform Adjustment (adding shims)

The ramp (outboard) end of the platform should be 1/2 to 3/4 inches higher than the truck floor when in the raised position. If the outboard end of the platform is sagging, add shims as described below. Shimming is a normal procedure as the liftgate ages and the parts become worn.

1. Position the necessary amount of "shim plates" in the contact area between the cam plates and platform.

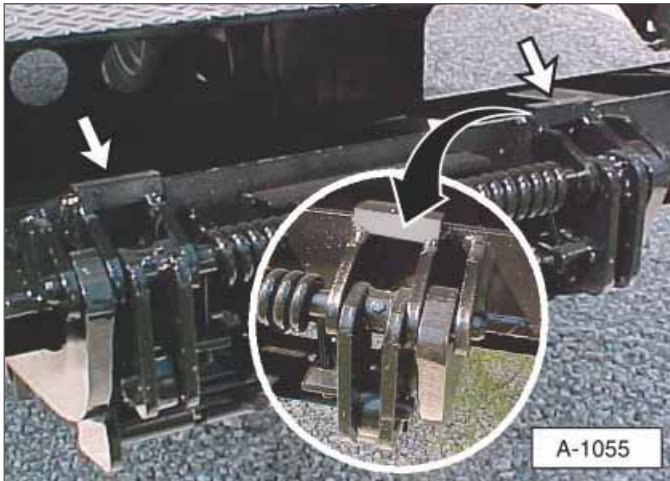

Add shims to this area to eliminate sagging.

2. Weld the steel shim plates to the blocks on the platform.
3. When the platform is lowered to the ground, it should touch at the lift arm end and at the ramp end.

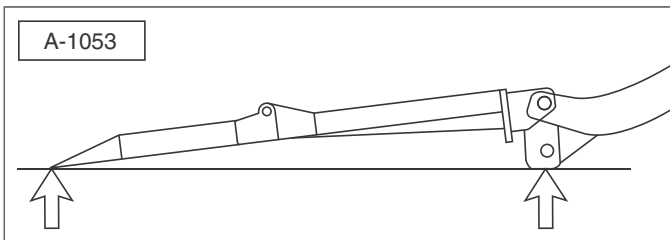

Liftgate should contact the ground at these two locations.

8.3.2 Replacing the Fuse

WARNING



Electric Arc Hazard

An electric arc can cause personal injury or property damage. To avoid personal injury, disconnect the power cable from the vehicle battery or batteries before replacing the fuse, or before disassembling the fuse holder.

1. Slide the rubber boots away from the fuse holder.

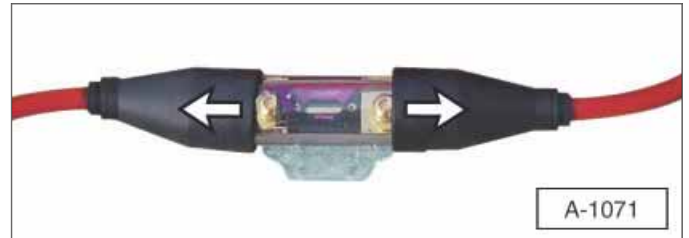

2. Unscrew the fuse holder ends from the fuse holder body and pull it apart.

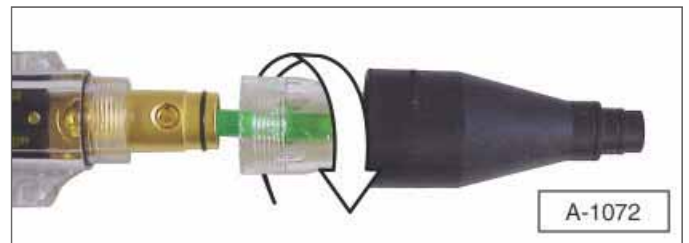

3. Slide the fuse holder body one direction (left or right) to expose the damaged fuse.
4. Loosen the screws from each end of the fuse, remove, and replace the fuse. Retighten the screws.
5. Re-assemble the fuse holder in reverse order. Be sure the rubber boots are sealed around the fuse holder and power cable.
6. Re-connect the power after you are certain the liftgate area is clear.

8.3.3 Checking Motor Start Solenoid and Power Cut-off Solenoid

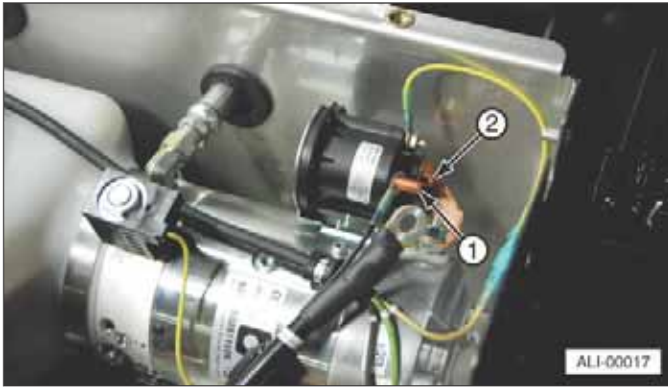

Motor start solenoid.

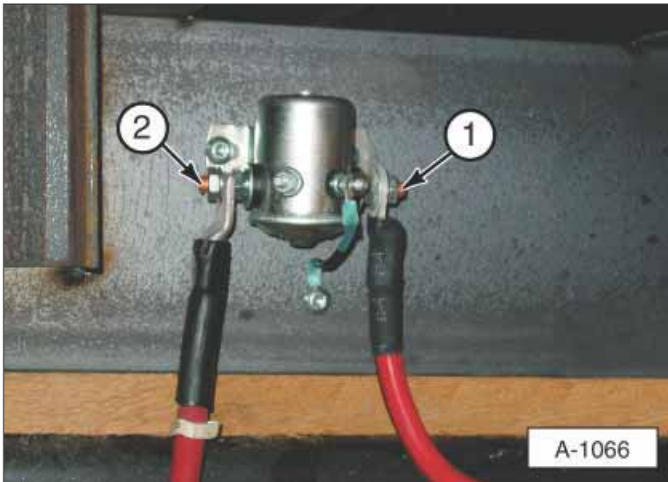

Power cut-off solenoid.

Both the motor start solenoid and power cut-off solenoid can be checked by bypassing the solenoid itself.

1. Use jumper cables for this test.
2. Connect one jumper cable to battery side (2) of the solenoid. Connect the other cable to motor side (1) of the solenoid.
3. If the liftgate is activated, the solenoid is defective and should be replaced.

8.3.4 Checking the Power Cable

To check for a defective power cable, run the motor directly from a spare battery using jumper cables.

1. Remove the battery connection to the motor.
2. Connect the negative jumper cable (ground) directly to the liftgate. Connect the positive cable to the terminal on the motor start solenoid.
3. If the motor operates, the battery cable is defective and should be replaced.

8.3.5 Checking Lowering Valve Cartridge and Solenoid

1. Place the liftgate on the ground in the open position.
2. Place a steel screwdriver over the top of the lowering valve solenoid.



3. Momentarily activate the control switch in the DOWN position. The screwdriver should be attracted to the magnetic field created by the solenoid.
4. If no magnetic pull is produced, the solenoid is defective and should be replaced. If the solenoid is activated, check the cartridge valve.
5. Remove the solenoid from the valve assembly.
6. Remove the valve cartridge from the pump body.
7. Clean the cartridge and blow it dry with compressed air (not greater than 30 psi). Also, blow out the pump body.
8. Use a small screwdriver and carefully press on the spool inside the cartridge. If the spool moves freely, the cartridge is good. If it does not move, replace the cartridge, as the spool could be bent, pitted, or damaged in some other way.



8.3.6 Solenoid Valve Screen



If the solenoid is working electrically, check the debris screen and clean if dirty.

8.3.7 Replacing Solenoid Valve



1. While installed in the pump, remove nut (1).
2. Remove coil (2) from cartridge (3).
3. Remove cartridge (3) from pump body.
4. O-ring (4) is not required on current models and can be discarded.

8.3.8 Checking Cylinder Piston Seals (drifting - caused by seal leakage)

Gravity Down Models

1. Remove the breather hose (gravity down models only).
2. Completely raise the liftgate and hold the switch in the "UP" position while checking for oil flowing out of the cylinder's breather port.
3. If a continuous flow of oil comes out of this port (while the liftgate is all the way up and the switch is held "UP"), then the piston seals are leaking and the cylinder should be replaced.

Power Down Models

1. Check the lowering valve. Make sure it is operating correctly and the valve is not sticking or dirty. Refer to "8.3.5 Checking Lowering Valve Cartridge and Solenoid" on page 45.
2. If the lowering valve is operating properly, then the drifting is most likely caused by worn piston seals. Replace the cylinder.

8.3.9 Checking System Pressure

For gravity down systems there is only one relief valve (power up). Power down models have two relief valve settings; one for raising the platform (power up) and one for lowering the platform (power down).

To check the "power up" pressure setting:

1. Place the liftgate on the ground and remove the pressure hose from the power up port of the pump.
2. Install a T-fitting (customer supplied) into the power up port.
3. Connect a pressure gauge and reconnect the hydraulic hose.

The pressure gauge must be rated above the maximum pressure of the liftgate. For example, use a 4000 psi pressure gauge on a 3000 psi maximum capacity liftgate.

4. Raise the liftgate and check the pressure on the gauge.

Low Pressure Threshold Chart		
Model	Power Up	Power Down
AST-1500, 2000	2800psi	350 psi
AST-2500	1850 psi	
AST-3000, 3500	2400 psi	
ATU-1800	2800 psi	
ATU-2500	1850 psi	
ATU-3000, 3500	2400 psi	
FP3-3000	3000 psi	
FP3 Power Down	3000 psi	

⚠️ WARNING



Crush Hazard

Do not stand or work in the platform's work area while operating the liftgate. Place the pressure gauge so it can be read while operating the liftgate from a safe location. Serious injury or death could result if this action is not followed.

5. Check the power down relief valve pressure in the same way as the gravity down system by installing a T-fitting and pressure gauge.

8.3.10 Checking Flow Control Valve



If the cylinder does not operate or operates slower than normal, remove the flow control valve and hook the hydraulic hose directly to the cylinder. If the cylinder operates properly, replace the flow control valve.

⚠️ WARNING



CRUSH HAZARD

Do not operate the liftgate without the flow control valve. Serious injury or death could result if this action is not followed.

8.3.11 Checking Control Switch Fuse

If the control switch is not operating the liftgate, check the in-line fuse located on the control cable inside the power unit box.

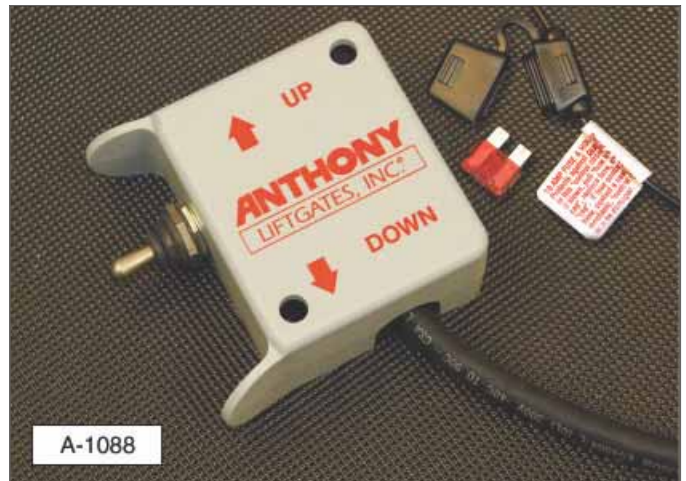

9. Troubleshooting

9.1 Troubleshooting Guide

Troubleshooting Chart		
Problem	Possible Causes	Possible Solution
Motor does not run when control switch is activated.	Cab cut-off switch.	Turn switch to ON position. "4.7.3 Cut-Off Switch Connection" on page 28.
	Dead battery.	Make sure battery is fully charged. Check for loose or corroded battery connections. Replace or recharge battery.
	Circuit protection (fuse or breaker).	Replace fuse.
	10 Amp fuse in power unit box.	Replace, if fuse is blown. If problem continues, check for shorts in the electrical system.
	Control box switch.	Check fuse. "8.3.2 Replacing the Fuse" on page 44.
	Motor start solenoid.	Check solenoid. "8.3.3 Checking Motor Start Solenoid and Power Cut-off Solenoid" on page 45
	Optional power cut-off solenoid.	Check solenoid. "8.3.3 Checking Motor Start Solenoid and Power Cut-off Solenoid" on page 45.
	Battery cable.	Connect motor directly to a spare battery using the procedure in the Maintenance section.
	Motor.	If the motor is determined to be defective, it should be replaced. Defective motors are typically caused by weak batteries (low voltage), loose connections, corrosion, or a poor ground.
	If liftgate is installed on a semi trailer, make sure the battery wire is 2 Gauge or heavier. Smaller wires can reduce the voltage, resulting in motor failures.	
If the motor does not operate in freezing conditions, make sure the motor housing does not contain water.		
Sagging platform.	Normal wear.	Add shims to platform. "8.3.1 Platform Adjustment (adding shims)" on page 44.
	Bushing wear where lift arms connect to platform.	Replace bushings.
	Structural damage.	Replace worn parts.
Foaming oil.	Air in the hydraulic hose(s).	Check oil level in reservoir. "8.1 Monthly Inspection" on page 43.
	Broken or loose fluid return tube.	Remove the oil reservoir and make sure the return tube is below the oil level. If the tube has turned or fallen out, reinstall it into the pump housing. Use a center punch to "stake" the tube into position.

Troubleshooting Chart		
Problem	Possible Causes	Possible Solution
Motor runs, but liftgate will not open or lower to the ground.	Structural damage. Check clearance between platform and dock bumpers.	Fix damage. Replace worn parts.
	Latch pin.	Slide the latch pin to the open position.
	Lowering valve solenoid.	Check the solenoid. "8.3.5 Checking Lowering Valve Cartridge and Solenoid" on page 45.
	Lowering valve cartridge.	Check, remove, and clean valve cartridge using the procedure in the Maintenance section. "8.3.5 Checking Lowering Valve Cartridge and Solenoid" on page 45.
	Flow control valve.	Remove flow control valve and hook hydraulic hose directly to the cylinder. If the cylinder operates properly, replace the valve. "8.3.10 Checking Flow Control Valve" on page 47.
Motor runs, but platform will not raise, will not raise rated capacity, or raises, but drifts down when control switch is released.	Load capacity has been exceeded.	Verify load capacity and adjust load weight.
	Structural damage.	Replace damaged parts.
	Low fluid level.	Fill reservoir. "8.1 Monthly Inspection" on page 43.
	Low Voltage.	Inspect the battery connection terminals and check the battery's Voltage (9 Volts minimum).
	Faulty lowering valve.	Solenoid or cartridge may need cleaning or replacement. See Maintenance section. "8.3.5 Checking Lowering Valve Cartridge and Solenoid" on page 45.
	Defective piston seals.	See Maintenance section for Checking Cylinder for Leakage. "8.3.8 Checking Cylinder Piston Seals (drifting - caused by seal leakage)" on page 46.
	Hydraulic pump is worn.	Replace hydraulic pump.
Latch pin is broken or bent.	Operator has lowered platform without releasing latch pin.	The latch pin is only used to prevent the liftgate from opening due to a pressure leak or pressure bleed-off over an extended period of time. Always release latch before opening liftgate.
Liftgate raises truck when lowered to the ground.	Power down system pressure is set too high.	See Maintenance section for Checking System Pressure. "8.3.9 Checking System Pressure" on page 46.
Liftgate will not open.	Platform operating area is not clear.	Clear platform operating area.
	Latch pin will not slide freely to release liftgate.	Activate the "UP" switch and raise the liftgate to the fully stored position. The latch pin should slide freely.

Troubleshooting Chart		
Problem	Possible Causes	Possible Solution
Platform lowers extremely slow.	Low oil level on power down models.	Fill reservoir. "8.1 Monthly Inspection" on page 43.
	Improper oil in hydraulic reservoir.	See Monthly Inspection. "8.1 Monthly Inspection" on page 43.
	Bushing wear where lift arms connect to platform.	Replace bushings.
	Damaged or kinked hydraulic hose.	Repair or replace.
	Cylinder rod is scored, pitted, or bent.	Replace cylinder.
	Flow control valve.	Remove flow control valve and hook hydraulic hose directly to the cylinder. If the cylinder operates properly, replace the valve. "8.3.10 Checking Flow Control Valve" on page 47.
	Lowering valve.	Solenoid or cartridge may need cleaning or replacement. See Maintenance section. "8.3.5 Checking Lowering Valve Cartridge and Solenoid" on page 45.
Platform raises partially and stops.	Load capacity has been exceeded.	Verify load capacity and adjust load weight.
	Structural damage.	Replace damaged parts.
	Low Voltage.	Recharge battery (if less than 9 Volts).
	Low pressure.	Refill reservoir. Check pump and motor. "8.1 Monthly Inspection" on page 43.
Platform will not lower.	Platform operating area is not clear.	Clear area.
	Structural damage.	Replace damaged parts.
	Low Voltage.	Recharge battery (if less than 9 Volts).
	Lowering valve.	See Maintenance section. "8.3.5 Checking Lowering Valve Cartridge and Solenoid" on page 45.
	Hydraulic pump and motor.	Replace power unit.

11. Limited Warranty

11.1 Limited Warranty

AXM - 1 yr Mechanical/Electric/Hydraulic
AST - 2 yrs Mechanical/Electric/Hydraulic
ATU - 3 yrs Mechanical/Electric/Hydraulic

Thank you for purchasing an Anthony liftgate. We strive to produce the most trouble free and reliable liftgates in the market. We are sure you will experience years of reliable operation. To further insure your confidence in Anthony, this warranty will cover your unit for 3 years or 8,000 cycles (whichever occurs first) on mechanical/ structural, electrical, and hydraulic operating parts. This warranty is extended to the original purchaser (user only) and is not transferable. The warranty term begins from the date of shipment from our factory or warehouse.

Anthony Liftgates Inc. will cover all failed components during the warranty period. Labor will be provided under our Flat Rate Warranty Schedule, in effect at the time of the part failure, and includes diagnosis time. Contact Anthony for current reimbursement amounts. For repairs NOT listed on the Flat Rate Warranty Schedule, contact the Anthony Warranty Department for approved reimbursement, prior to performing repairs. Anthony Liftgates Inc. reserves the right of determination of whether a component is defective or has failed. This warranty applies to Anthony liftgates installed, operated, and maintained in accordance with Anthony Liftgates Inc. installation, operation, and maintenance manuals, videos, etc.

Certain Anthony models have published Lifetime Warranties on listed components, as published in current literature. This additional coverage will be detailed on the published operation components, providing the unit has been operated and maintained within the intended usage.

Anthony Liftgates, Inc. will process all claims and determine their eligibility for authorization upon the receipt of the failed part, the identification of the claimant, and the liftgate serial number. All parts must be returned freight prepaid and following the instructions given by the Anthony Warranty Department. Freight collect shipments will not be accepted.

PLEASE NOTE THAT NO CLAIMS WILL BE PROCESSED WITHOUT THE PART, THE CLAIMANT'S INFORMATION, AND THE LIFTGATE SERIAL NUMBER.

Claims not submitted within 30 days of repair date will be denied.

NOTE: ALL CLAIMS MUST BE COMPLETED ON THE ANTHONY LIFTGATES INC. WARRANTY CLAIM FORM.

This form provides all the necessary information.

Upon approval of the claim, Anthony will, at the direction of the claimant, return a replacement part and labor allowance, or a parts credit based on current distributor net pricing, and the appropriate flat rate labor allowance.

Anthony Liftgates, Inc. is not responsible or liable for loss of time, cost, labor, material, profits, direct or indirect damages caused by failed components, whether due to rights arising under purchase, order, contract of sale or independently thereof, and whether or not such claim is based on contract, tort, or warranty. The sale of products of Anthony Liftgates, Inc. under any other warranty or guarantee express or implied is not authorized. This warranty does not cover misuse, abuse, damage, or product finish, normal wear, maintenance adjustments, careless or negligence of use or maintenance. Modifications to our product are not covered unless prior authorized by Anthony.

Purchased Parts warranty is 1 year from date of purchase and covers replacement of part only.

If you require assistance or have questions, please contact Anthony Liftgates Inc. at 815-842-3383.

NOTE: Most (not all) Anthony liftgate models incorporate our Service-Free feature. Service-Free refers to the fact that these models require no routine or scheduled lubrication of the major pivot points that contain our service-free bushings. Normal repair and maintenance of your liftgate, per our instruction, is necessary for ALL Anthony liftgates.

Anthony Liftgates, Inc.
1037 W. Howard St. P.O. Box 615
Pontiac, IL 61764-0615

PH: 815-842-3383
FAX: 815-844-3612
E-Mail: warrantyclaims@anthonyliftgates.com

11.2 Warranty Policy and Procedure

All warranty claims must be completed on the Anthony Liftgates Warranty Claim Form utilizing the Flat Rate Warranty Schedule. See the current rates as listed for each model. Using this process will allow for quick and accurate credit payment.

Claims will not be processed without the failed part returned (pre-paid) to Anthony Liftgates, and the warranty claim form completed.

NOTE: When returning defective parts for warranty consideration, be sure to call ahead for a Return Authorization Number.

If you require further assistance or have questions, please contact the Anthony Liftgates Warranty Dept. at 815-842-3383 or email: warrantyclaims@anthonyliftgates.com.

Notes

Notes

ANTHONY
LIFTGATES, INC.®

AST



ANTHONY LIFTGATES, INC.
1037 W. HOWARD ST. • P.O. BOX 615
PONTIAC, IL 61764-0615
PH: 815-842-3383
FAX: 815-844-3612
TOLL FREE: 800-482-0003
WWW.ANTHONYLIFTGATES.COM