



STEEL-CASTER™

STEEL-CASTER™ Hopper Spreader

With Electric Motors

#99000, 99001, 99005, 99009,
99000-1, 99001-1, 99005-1, 99009-1

Owner's Manual
Original Instructions

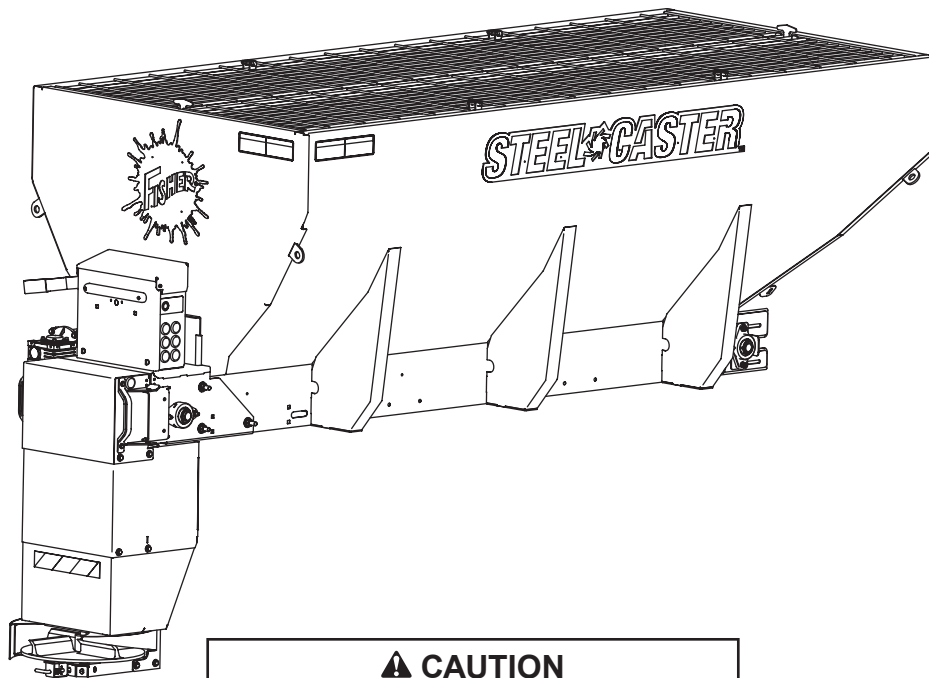

⚠ CAUTION

Read this document before operating
or servicing the spreader.

This manual is for FISHER® STEEL-CASTER Hopper Spreaders with serial numbers beginning with 160905 and higher.

This manual supersedes all editions with an earlier date.

TABLE OF CONTENTS

PREFACE	4	Controlling Material Application	15
Owner's Information Form	4	BLAST/Maximum Application	15
SAFETY	5	Cab Control Modes.....	15
Safety Definitions.....	5	Standby Mode	15
Warning/Caution Labels	5	Ready Mode	15
Serial Number Label	6	ON Mode	15
Safety Precautions.....	6	Error Mode	15
Fuses	7	Cab Control Codes – Table	16
Personal Safety.....	7	Setup Procedures	18
Fire and Explosion	7	Calibrate the Empty Hopper Setting.....	18
Cell Phones.....	7	Adjust LED Brightness Level.....	18
Ventilation	8	Spread Pattern Adjustment.....	19
Battery Safety	8	Material Spread Patterns.....	20
Noise.....	8	Dump Function.....	21
Vibration.....	8	Accessory Work Light.....	21
Torque Chart.....	8	MAINTENANCE	22
LOADING	9	Grease Fittings	22
Certification.....	9	Conveyor Pintle Chain Tension.....	23
Spreader Specifications.....	9	Spinner Belt Alignment	23
Material Weights	9	Removing the Chute	24
Load Volume	10	After Each Use.....	24
Determining Vehicle Payload.....	10	Cab Control.....	24
Determining Vehicle Payload Worksheet.....	11	Storage	24
MOUNTING THE SPREADER	12	At the End of Each Season or	
Install Hopper in Truck Bed.....	12	After Extended Storage	24
Tie-Down Straps	12	Fuse Replacement.....	24
Chute Installation	13	Recycle	24
Chute Configurations.....	13	ELECTRICAL COMPONENTS	25
Install Chute to Hopper.....	13	TROUBLESHOOTING GUIDE	27
OPERATING THE SPREADER—CAB CONTROL ..	14		
Powering the Control	14		
Starting and Stopping Spreader	14		

PREFACE

This manual has been prepared to acquaint you with the safety information, operation and maintenance of your new hopper spreader. Please read this manual carefully and follow all recommendations. This will help ensure profitable and trouble-free operation of your hopper spreader. Keep this manual accessible. It is a handy reference in case minor service is required.

When service is necessary, bring your hopper spreader to your distributor. They know your spreader best and are interested in your complete satisfaction.

NOTE: This spreader is designed to spread snow and ice control materials only. Do not use it for purposes other than those specified in this manual.

Register your spreader online at www.fisherplows.com

OWNER'S INFORMATION

Owner's Name: _____

Date Purchased: _____

Outlet Name: _____ Phone: _____

Outlet Address: _____

Vehicle Model: _____ Year: _____

Spreader Type (Model): _____ Serial #: _____

Length: _____ Weight: _____ lb/kg: _____

SAFETY

SAFETY DEFINITIONS

⚠ WARNING

Indicates a potentially hazardous situation that, if not avoided, could result in death or serious personal injury.

⚠ CAUTION

Indicates a potentially hazardous situation that, if not avoided, may result in minor or moderate injury. It may also be used to alert against unsafe practices.

NOTE: Indicates a situation or action that can lead to damage to your spreader and vehicle or other property. Other useful information can also be described.

WARNING/CAUTION LABELS

Become familiar with and inform users about the warning and caution labels on the spreader.

NOTE: If labels are missing or cannot be read, see your sales outlet.

Caution Label—Lifting



67272

Hoppers with single screen support

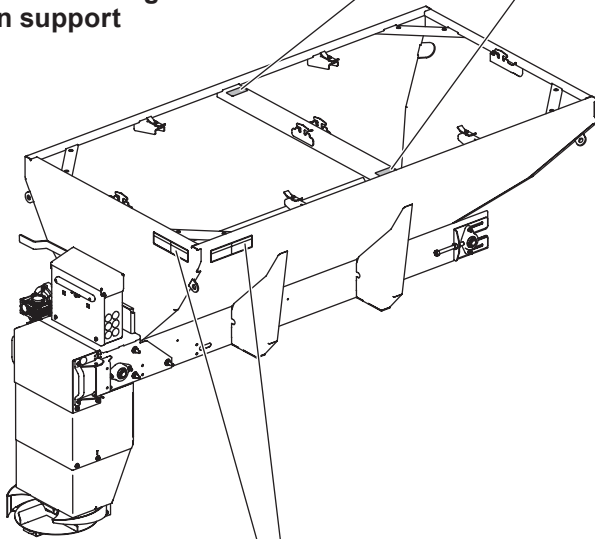

Hoppers with two screen supports

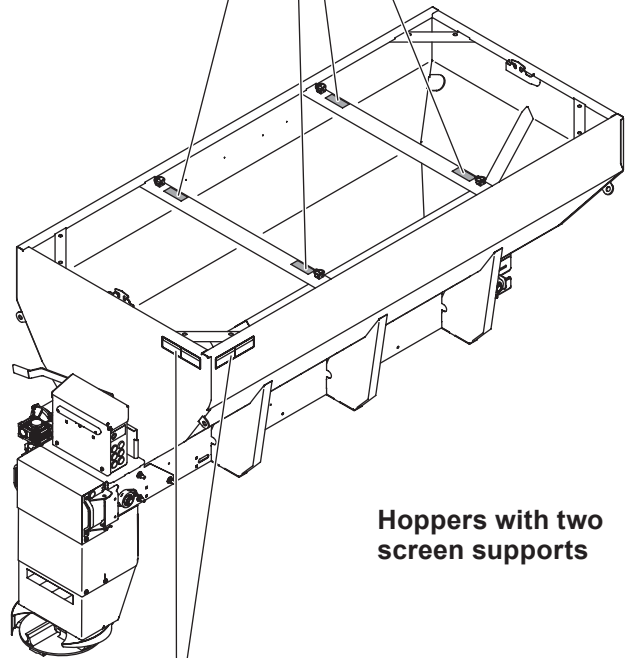

Warning/Caution Label (both sides of hopper)

	<p>⚠ WARNING</p> <ul style="list-style-type: none"> • DO NOT exceed GVWR or GAWR with spreader and load. • Turn spreader OFF before filling, adjusting or cleaning. • Bystanders to stay a minimum of 25 feet away from operating spreader. • DO NOT climb into or ride on spreader. • Keep hands, feet and clothing away from moving conveyor and spinner. 		<p>⚠ CAUTION</p> <ul style="list-style-type: none"> • Read Owner's Manual before operating or servicing spreader. • Empty and clean spreader after every use.
	<p>68584</p>		

SAFETY

SERIAL NUMBER LABEL

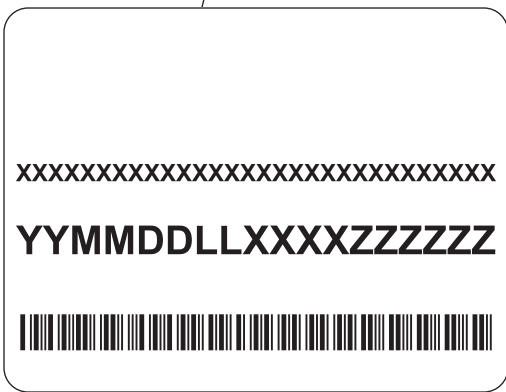
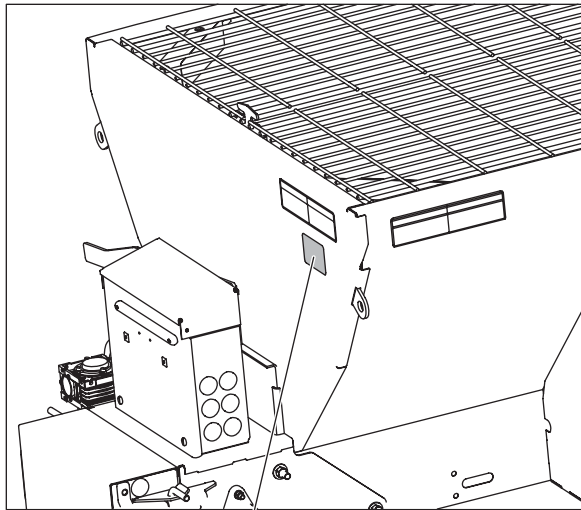

Code	Definition
YY	2-Digit Year
MM	2-Digit Month
DD	2-Digit Day
LL	2-Digit Location Code
XXXX	4-Digit Sequential Number
ZZZZZ	5- to 7-Digit Assembly PN

SAFETY PRECAUTIONS

Improper installation and operation could cause personal injury and/or equipment and property damage. Read and understand labels and the Owner's Manual before installing, operating, or making adjustments.

⚠ WARNING

- Driver to keep bystanders minimum of 25 feet away from operating spreader.
- Before working with the spreader, secure all loose-fitting clothing and unrestrained hair.
- Before operating the spreader, verify that all safety guards are in place.
- Before servicing the spreader, wait for conveyor, auger, and spinner to stop.
- Do not climb into or ride on spreader.

⚠ WARNING

Overloading could result in an accident or damage. Do not exceed GVWR or GAWR ratings as found on the driver-side vehicle door cornerpost. See Loading section to determine maximum volumes of spreading material.

⚠ WARNING

Do not install the control for this product in the deployment path of an air bag. Refer to vehicle manufacturer's manual for air bag deployment area(s).

⚠ WARNING

With chute removed, use dump switches to operate conveyor.

⚠ CAUTION

If rear directional, CHMSL light, or brake stoplights are obstructed by the spreader, the lights shall be relocated, or auxiliary directional or brake stoplights shall be installed.

SAFETY

CAUTION

During the hopper installation we recommend the addition of an OSHA compliant Backup Alarm. This alarm is required for OSHA governed employers.

CAUTION

- Do not operate a spreader in need of maintenance.
- Before operating the spreader, reassemble any parts or hardware removed for cleaning or adjusting.
- Before operating the spreader, remove materials such as cleaning rags, brushes, and hand tools from the spreader.
- Before operating the spreader, read the engine owner's manual, if so equipped.
- While operating the spreader, use auxiliary warning lights, except when prohibited by law.
- Tighten all fasteners according to the Torque Chart. Refer to Torque Chart for the recommended torque values.

CAUTION

Disconnect electric and/or hydraulic power and tag out if required before servicing or performing maintenance.

CAUTION

 DO NOT leave unused material in hopper. Material can freeze or solidify, causing unit to not work properly. Empty and clean after each use.

NOTE: Lubricate grease fittings after each use. Use a good quality multipurpose grease.

FUSES

The electrical system contains several blade-style automotive fuses. If a problem should occur and fuse replacement is necessary, the replacement fuse must be of the same type and amperage rating as the original. Installing a fuse with a higher rating can damage the system and could start a fire. Fuse Replacement, including fuse ratings and locations, is located in the Maintenance section of this Owner's Manual.

PERSONAL SAFETY

- Remove ignition key and put the vehicle in park or in gear to prevent others from starting the vehicle during installation or service.
- Wear only snug-fitting clothing while working on your vehicle or spreader.
- Do not wear jewelry or a necktie, and secure long hair.
- Wear safety goggles to protect your eyes from battery acid, gasoline, dirt, and dust.
- Avoid touching hot surfaces such as the engine, radiator, hoses, and exhaust pipes.
- Always have a fire extinguisher rated BC handy, for flammable liquids and electrical fires.

FIRE AND EXPLOSION

WARNING

Gasoline is highly flammable and gasoline vapor is explosive. Never smoke while working on vehicle. Keep all open flames away from gasoline tank and lines. Wipe up any spilled gasoline immediately.

Be careful when using gasoline. Do not use gasoline to clean parts. Store only in approved containers away from sources of heat or flame.

CELL PHONES

A driver's first responsibility is the safe operation of the vehicle. The most important thing you can do to prevent a crash is to avoid distractions and pay attention to the road. Wait until it is safe to operate Mobile Communication Equipment such as cell phones, text messaging devices, pagers or two-way radios.

SAFETY

VENTILATION

⚠ WARNING

Vehicle exhaust contains lethal fumes. Breathing these fumes, even in low concentrations, can cause death. Never operate a vehicle in an enclosed area without venting exhaust to the outside.

BATTERY SAFETY

⚠ CAUTION

Batteries normally produce explosive gases which can cause personal injury. Therefore, do not allow flames, sparks, or lit tobacco to come near the battery. When charging or working near a battery, always cover your face and protect your eyes, and also provide ventilation.

- Batteries contain sulfuric acid, which burns skin, eyes, and clothing.
- Disconnect the battery before removing or replacing any electrical components.

NOISE

Airborne noise emission during use is below 70 dB(A) for the spreader operator.









VIBRATION

Operating spreader vibration does not exceed 2.5 m/s² to the hand-arm or 0.5 m/s² to the whole body.

TORQUE CHART

⚠ CAUTION

Read instructions before assembling. Fasteners should be finger tight until instructed to tighten according to the Torque Chart. Use standard methods and practices when attaching spreader, including proper personal protective safety equipment.

Recommended Fastener Torque Chart					
Inch Fasteners Grade 5 and Grade 8					
Size	Torque (ft-lb)		Size	Torque (ft-lb)	
	 Grade 5	 Grade 8		 Grade 5	 Grade 8
1/4-20	8.4	11.9	9/16-12	109	154
1/4-28	9.7	13.7	9/16-18	121	171
5/16-18	17.4	24.6	5/8-11	150	212
5/16-24	19.2	27.3	5/8-18	170	240
3/8-16	30.8	43.6	3/4-10	269	376
3/8-24	35.0	49.4	3/4-16	297	420
7/16-14	49.4	69.8	7/8-9	429	606
7/16-20	55.2	77.9	7/8-14	474	669
1/2-13	75.3	106.4	1-8	644	909
1/2-20	85.0	120.0	1-12	704	995
Metric Fasteners Class 8.8 and 10.9					
Size	Torque (ft-lb)		Size	Torque (ft-lb)	
	 Class 8.8	 Class 10.9		 Class 8.8	 Class 10.9
M6 x 1.00	7.7	11.1	M20 x 2.50	325	450
M8 x 1.25	19.5	26.9	M22 x 2.50	428	613
M10 x 1.50	38.5	53.3	M24 x 3.00	562	778
M12 x 1.75	67	93	M27 x 3.00	796	1139
M14 x 2.00	107	148	M30 x 3.50	1117	1545
M16 x 2.00	167	231	M33 x 3.50	1468	2101
M18 x 2.50	222	318	M36 x 4.00	1952	2701
These torque values apply to fasteners except those noted in the instructions.					

LOADING

This Owner's Manual covers vehicles that have been recommended for carrying the hopper spreader. Please see your local dealer for proper vehicle applications.

CERTIFICATION

⚠ WARNING

New untitled vehicle installation of a spreader requires National Highway Traffic Safety Administration altered vehicle certification labeling. Installer to verify that struck load of snow or ice control material does not exceed GVWR or GAWR rating label and complies with FMVSS.

⚠ WARNING

Overloading could result in an accident or damage. Do not exceed GVWR or GAWR as found on the driver-side cornerpost of vehicle.

⚠ CAUTION

Never use wet materials or materials with foreign debris with any of these spreaders. These units are designed to handle dry, clean, free-flowing material.

⚠ CAUTION



Read and adhere to manufacturer's ice-control material package labeling, including Material Safety Data Sheet requirements.

MATERIAL WEIGHTS

Material	Density		
	(lb/ft ³)	(lb/yd ³)	(kg/m ³)
Salt	80	2160	1282
Sand	100	2700	1602

Material densities are approximate and are based on dry, loose material. It is the responsibility of the operator to know the weight of the material to be spread and the vehicle carrying capacity.

SPREADER SPECIFICATIONS

Hopper Model	Overall Length (in)	Bed Length (in)	Empty Weight (lb)	Overall Width (in)	Bed Height (in)	Capacity Struck (cu yd)
7 ft (Reg. Cap.)	106	86.5	640	50	37.5	1.7
8 ft (Reg. Cap.)	119	96	761	50	39.5	1.9
9 ft (Reg. Cap.)	149	108	846	50	40.6	3.0
9 ft (High Cap.)	130	115	960	70	47	4.2

LOADING

LOAD VOLUME

Hopper Model	Load Volume (cu yd)			
	A	B	C	D
7 ft (Reg. Cap.)	2.1	1.7	1.3	0.5
8 ft (Reg. Cap.)	2.4	1.9	1.5	0.6
9 ft (Reg. Cap.)	3.5	3.0	1.7	0.7
9 ft (High Cap.)	4.8	4.2	3.4	1.5

7' Hopper

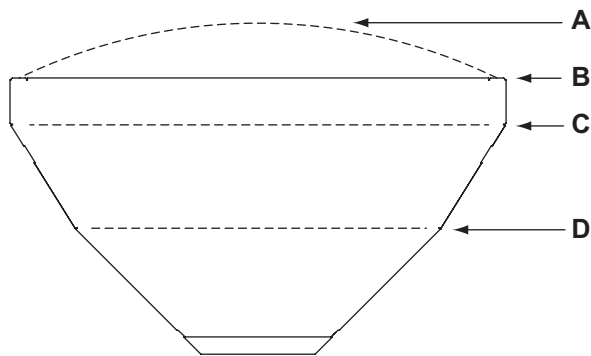

8' and 9' Hoppers

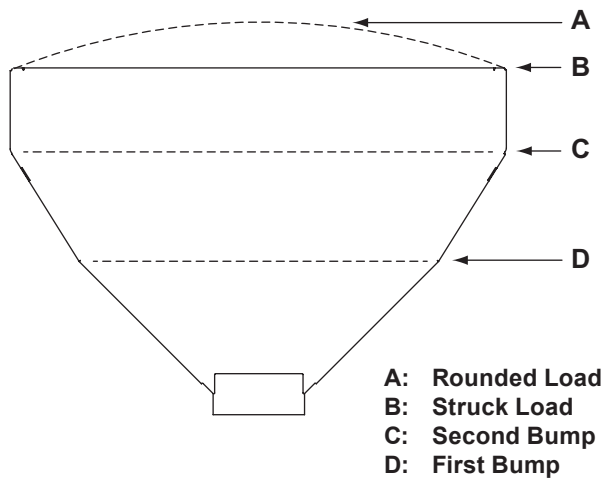

DETERMINING VEHICLE PAYLOAD

⚠ WARNING

Overloading could result in an accident or damage. Do not exceed GVWR or GAWR ratings as found on the driver-side door cornerpost of the vehicle. See Loading Section to determine maximum volumes of spreading material.

1. Install the hopper spreader and optional equipment according to the installation instructions.
2. Install or attach any other equipment that will be on the vehicle while the hopper spreader will be in use (step bumper, trailer hitch, snowplows, etc.). Fill gas tanks.
3. Obtain the Gross Vehicle Weight Rating (GVWR), Front Gross Axle Weight Rating (FGAWR) and Rear Gross Axle Weight Rating (RGAWR) from the certification label located inside the driver-side door jamb or door.
4. With the occupants in the truck for normal hopper spreader operation, weigh the vehicle to obtain gross vehicle weight (GVW).
5. Subtract the GVW from the GVWR to determine the available material payload.
6. Obtain the weight per cubic yard (lb/cu yd) of the desired material. Divide the weight into the payload to determine the maximum volume of material that can be carried.
7. Refer to the Load Volume table and diagrams to determine the maximum fill level for the material.
8. Fill the hopper with material to the calculated level. Reweigh the vehicle with occupants and verify that the Loaded Gross Vehicle Weight, Front Gross Axle Weight and Rear Gross Axle Weight are less than the vehicle's ratings.
9. Repeat Steps 6–8 for each type of material.

The worksheet for Determining Vehicle Payload (next page) includes an example.

LOADING

Determining Vehicle Payload Worksheet

	Material Type	<i>Example:</i> Dry Salt				
A	Equipment installed when vehicle was weighed	8' Stainless Steel Hopper Spreader				
B	Front Gross Axle Weight Rating [FGAWR] (lb)	6000				
C	Rear Gross Axle Weight Rating [RGAWR] (lb)	7000				
D	Gross Vehicle Weight Rating [GVWR] (lb)	11,000				
E	Gross Vehicle Weight [GVW], empty (lb)	- 7402				
F	Payload Available (lb)	= 3598				
G	Material Density (lb/cu yd)	÷ 2160				
H	Maximum Volume (cu yd)	= 1.67				
I	Maximum Material Fill Level, approx. Refer to Load Volume table and diagrams.	C				
J	Loaded Front Gross Axle Weight (lb) Must be less than weight in Row B.					
K	Loaded Rear Gross Axle Weight (lb) Must be less than weight in Row C.					
L	Loaded Gross Vehicle Weight [GVW] (lb) Must be less than weight in Row D.					

MOUNTING THE SPREADER

INSTALL HOPPER IN TRUCK BED

NOTE: Periodically throughout the snow and ice control season, verify that mounting devices are secure.

⚠ CAUTION

Before lifting, verify that the hopper is empty of material. The lifting device must be able to support the spreader's weight as shown in the spreader specifications table.

1. Remove the top screens and set them aside. Remove any debris from inside the hopper.
2. If the material chute has been stored inside the hopper, remove the chute and set it aside. Two or more people are recommended for this step, as the chute weighs more than 70 lb.
3. Remove the vehicle tailgate.
4. Lift the spreader by the four diagonal corner rails, as shown, using slings or chains. Move the spreader into the truck bed.

Use all 4 rails when lifting.

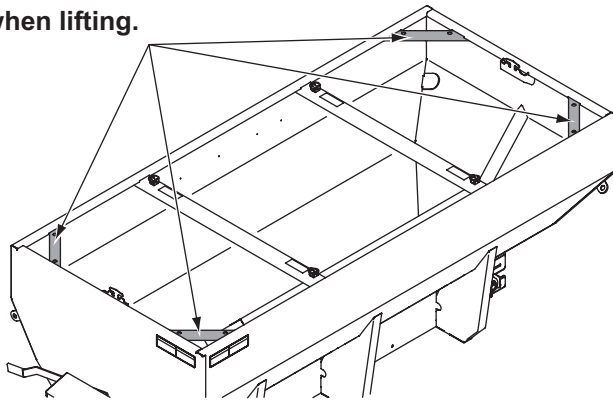

⚠ WARNING

Spreader shall be bolted to vehicle frame. Do not rely on the tie-down chains or straps alone to hold spreader in vehicle.

5. Adjust the spreader position to align the holes in the hopper support legs with the mounting holes in the truck bed. If mounting holes are not already drilled, refer to the hopper spreader Installation Instructions.

Install the spreader to the truck bed using four 5/8" Grade 5 bolts (as required by the vehicle application), 5/8" flat washers on both sides, and 5/8" locknuts

If the mounting holes are not directly over the truck box supports, the truck bed must be braced to the frame to prevent buckling or deforming the truck bed. Accessory mounting bars are available for installations that require additional bracing. Contact your authorized dealer.

NOTE: Pay special attention when drilling or clamping dissimilar metals to aluminum bodies. Galvanic corrosion can occur if not handled properly. Contact vehicle manufacturer for recommended attachment practices.

6. Connect the vehicle-side harness to the hopper-side harness.
7. Reinstall the top screens.

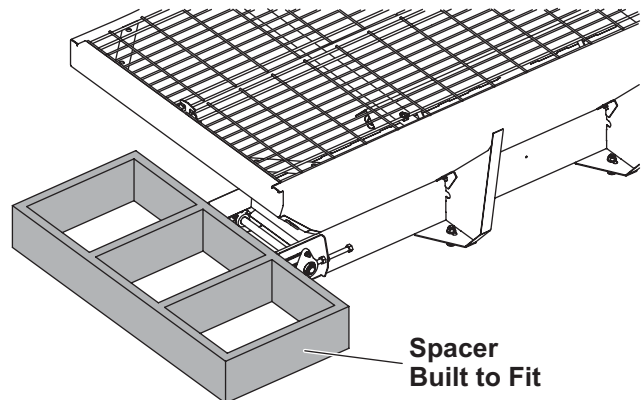

8. Install the sill spacer between the end of the hopper sill and the front of the truck bed as shown. If you do not have a spacer, refer to the Hopper Spreader Installation Instructions for directions on building one. Failure to install this spacer could result in damage to the spreader.

Tie-Down Straps

Install tie-down straps from the tie-down loops on the spreader body to the truck frame. Use one strap per loop, pulling diagonally away from the hopper body.

MOUNTING THE SPREADER

CHUTE INSTALLATION

Chute Configurations

The chute comes in two lengths.

- **7' and 8' Hoppers:** Short chute configuration is standard. The chute extends 14.75" below the truck bed and will fit most pickup trucks.
- **9' Hoppers:** Long chute configuration is standard. The chute extends 26.75" below the truck bed. Required for flat bed and dump truck installations.

Long Chute

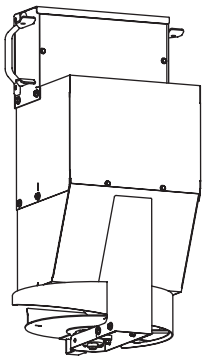

Short Chute

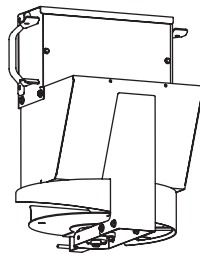

Ideal spinner height is 12"–18" above the ground. For some installations the chute length may need to be adjusted to achieve the desired spinner height.

If no length adjustment is required, go to "Install Chute to Hopper."

Extending a short chute requires installation of the Chute Middle Section Kit (available from your authorized dealer). Follow the instructions packed with the kit.

A long chute can be shortened by removing the middle section. Refer to the Hopper Spreader Installation Instructions.

Install Chute to Hopper

1. Two people are recommended for this step. Pick up the chute from each side and slide the chute hinges over the hopper hinges. Line up the hinge pivot holes.

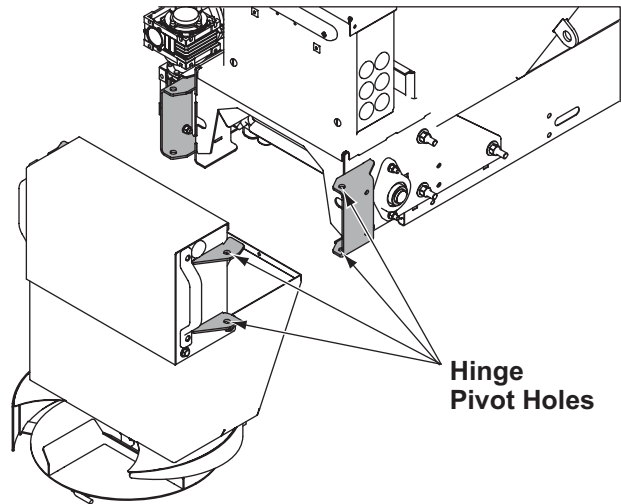

2. Insert a 1/2" x 8-1/4" chute pin on each side and secure with a 3/32" x 2-1/4" cotter pin.

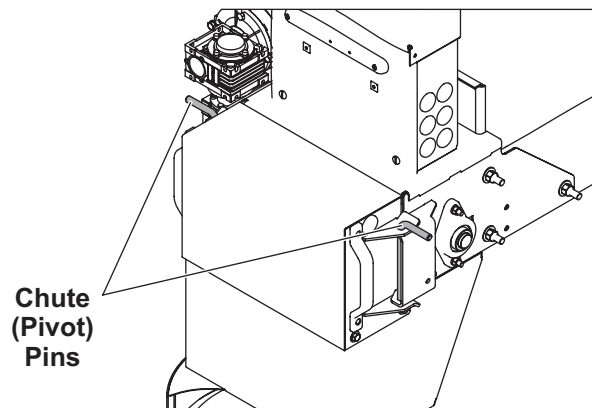

The chute can pivot on either pin to provide access to the feed area of the hopper. An interlock prevents the feed system from running if the chute is rotated to either side or removed.

3. Connect the chute motor plug to the hopper harness plug.

OPERATING THE SPREADER – CAB CONTROL

⚠ WARNING

Never operate equipment when under the influence of alcohol, drugs, or medications that might alter your judgment and/or reaction time.

⚠ WARNING

Never exceed 45 mph (72 km/h) when loaded spreader is attached to vehicle. Braking distances may be increased and handling characteristics may be impaired at speeds above 45 mph (72 km/h).

⚠ WARNING

Never allow children to operate or climb on equipment.

If any button is pressed on the control, it will wake and check again for spreader connection. If no spreader is detected, it will act as described above. If a spreader is detected, it will transition to Ready mode.

STARTING AND STOPPING SPREADER

⚠ WARNING

Before starting the spreader, the driver shall verify that all bystanders are a minimum of 25 feet away from operating spreader.

To start the spreader, press the ON/OFF button. The control backlights are illuminated when the vehicle ignition is ON and the spreader is connected. When the spreader is ON, the ON/OFF button and inner arc around each control knob will also illuminate.

To stop the spreader, press the ON/OFF button again.

The ON/OFF button also operates as an emergency stop when required.

POWERING THE CONTROL

Power is not applied to the control until the vehicle ignition is turned to ACC or ON. Once the control has power it performs a light check and displays the software version on the status display. The control then checks for a connected spreader. If no spreader is detected, the control does the following:

- **nC** (no connection) appears on the red status display for five seconds;
- A single beep;
- Control enters Standby mode with no lights illuminated.

NOTE: The vehicle ignition must be ON to start the spreader.

NOTE: If vehicle ignition is turned OFF while spreader is running, the motors will stop.

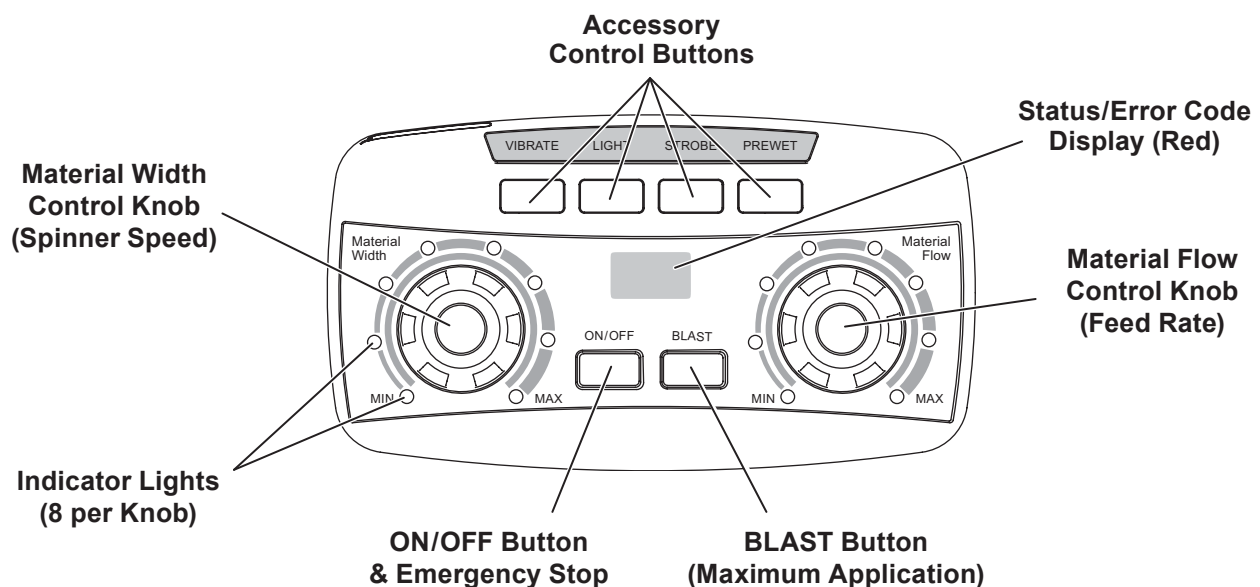

OPERATING THE SPREADER – CAB CONTROL

CONTROLLING MATERIAL APPLICATION

The material application settings can be adjusted while spreader is ON or OFF. Settings are shown by the indicator lights around the control knobs. When the spreader is OFF, a single LED will light to show the current setting. When the spreader is ON, the number of blue LEDs illuminated will increase/decrease as the knobs are turned clockwise/counterclockwise.

The hopper drive will not deliver material until the ON button is pressed.

The Material Width (left) knob controls spinner speed. Turning the knob clockwise will increase the width of the application area.

The Material Flow (right) knob controls the hopper drive. Turning the knob clockwise will increase the feed rate of material to the spinner.

Turning the control knobs counterclockwise will decrease the width of the application area and the feed rate of material, respectively.

BLAST/Maximum Application

1. Press and hold the BLAST button when maximum flow rate and application area are needed temporarily. The BLAST button will illuminate while depressed.
2. Release the button when maximum application settings are no longer needed.

NOTE: Spinner speed and material feed rate revert to the previous settings once the BLAST button is released.

CAB CONTROL MODES

Standby Mode

Vehicle ignition is set to ACC or ON; cab control is OFF. Control has power. No spreader was detected. No lights are illuminated on the control. Press any button to wake.

Ready Mode

Vehicle ignition is set to ACC or ON; cab control is OFF. Control has power. Spreader is detected.

The Material Width and Material Flow control knobs can be set to start-up conditions, but the spinner and drives will not operate until the cab control is turned ON.

Accessory lights and vibrator (if installed) are operational. The BLAST function is not operational.

ON Mode

Vehicle ignition is set to ACC or ON; cab control is ON.

Spinner and hopper motors will start. All cab control functions are operational. Accessory lights and vibrator (if installed) are operational.

During normal spreader operation, **no control codes are displayed**. Information or setup codes will appear when relevant. These codes will not stop spreader operation.

Error Mode

When an error condition occurs, spreader operation will shut down. A two-digit error code will flash on the display and a beep will sound. If there are multiple error codes, the codes will flash in a repeating sequence.

Refer to the Error Codes portion of the following Cab Control Codes table. Also see the Troubleshooting Guide section of this manual.

Once the error condition has been resolved, press the ON/OFF button to clear the error code(s). Press the ON/OFF button again to resume spreader operation.

The error code will reappear if the error condition has not been rectified. If the error condition persists, contact your authorized dealer.

Multiple resets within a short time frame will cause the hopper module to time out if components are overheating. The control will display an **EF** error code.

Accessory work lights and strobe lights can be used when an error code is in effect and will remain in their current state. The vibrator and pre-wet will not function.

OPERATING THE SPREADER – CAB CONTROL

CAB CONTROL CODES

Setup Codes		
Code	Definition	Procedure
Cb	Calibrate the Empty Hopper setting.	With control in ON mode, press and hold the left control knob until the Cb code displays. Calibration cycle is automatic.*
Cc	Clear calibration data for Empty Hopper setting; clear EH code.	Press the right control knob to clear all calibration data during the calibration cycle.
LS	Set LED brightness level.	With control in Ready mode, press and hold left control knob to get LS code. Release pressure and turn left control knob to desired brightness setting. Wait for confirming SL code to display.*
SL	Confirms that LED brightness level has been reset.	

* For full instructions, see the "Setup Procedures" section.

Information Codes		
Code	Definition	Response
dU	Spreader is in dump mode: <ul style="list-style-type: none"> • Material chute is open. • Back Dump buttons are enabled. 	To operate the dump function, see instructions in the "Operating the Spreader" section of this manual. If dU code displays when the material chute is closed and latched, contact authorized dealer.
EH	Empty hopper (beep will sound).	Check hopper for material. Recalibrate Empty Hopper setting as described above for Cb code.
Lb	Low battery. Hopper module is sensing < 10V. (Lb becomes an error code when module senses < 6V.)	Refer to the Lb row under "Error Codes" (next table).

Error Codes – Spreader Operation Stopped			
Code	Definition	Possible Cause	Suggested Solution
bb	Bad button.	Button is stuck. Button was pressed while vehicle ignition was entering ACC or START mode.	Inspect control. Free up button. Do not press any spreader cab control buttons while the vehicle ignition is being engaged.
bH	Bad hopper.	Possible module or control mismatch.	Replace control or module. Use only genuine service parts. Contact authorized dealer.
CE	No communication with spreader module.	Loose connection. Module lost power.	Confirm that spreader and control harnesses are connected to the vehicle harness. Check power to spreader module, all connections, fuses, and power studs. Check that B port is plugged in.
CP	Chute present fault.	Chute is open. Bad connection at chute position mag switch. (Can occur when driving on rough surface.)	Close the chute. Reset the control by pressing the ON/OFF button. If CP code continues to display, contact authorized dealer.
Ct	Control is hot.	Cab temperature is too high. Control overheated.	Turn off spreader and allow control to cool off.

Table continues on next page.

OPERATING THE SPREADER – CAB CONTROL

CAB CONTROL CODES *continued*

Error Codes – Spreader Operation Stopped			
Code	Definition	Possible Cause	Suggested Solution
EF	Excessive drive faults.	Too many HO and/or SO error codes; hopper module overheating.	Control times out for 60 seconds. Ensure that conveyor and/or spinner are not jammed.
HO	Hopper overload – software trip.	Drive system has high current. Material is jammed.	Inspect conveyor; clear material jam or fix chain as needed.
HO.	Hopper overload – hardware trip.	Chain is damaged.	
HP	Hopper power issue. No motor present.	Hopper drive motor is not connected. Possible motor defect.	Check connections to the conveyor drive motor (P—FEED and GND posts on the module and studs on the motor). Replace the motor.
Lb	Low battery. Hopper module is sensing $\leq 6V$.	Bad connection or low battery. Snowplow or other vehicle power use may be driving down voltage.	Voltage is measured at the hopper module, so Lb code may indicate cable voltage loss. Check battery, alternator and connections.
nC	No connection.	Spreader not connected to vehicle harness.	Connect vehicle and spreader harness. Check vehicle harness fuse. Inspect spreader and vehicle harnesses. Check module.
OH	Overheating.	Spreader module is too hot. Spreader module malfunction.	Allow a cool-off period of 60 seconds or longer. Check for loose harness connections. Check accessory connections. Check integrity of accessory wiring and harness. Clear jammed material. Contact authorized dealer.
OH.	Overheating module – microprocessor.	Accessories wiring/function problem. Drive motor overload.	
rS	Reset of spreader module.	Power loss to module detected on startup.	Reset the control by pressing the ON/OFF button. Check vehicle harness and battery connection.
SO	Spinner drive overload – software trip.	Material jammed in chute. Spinner shaft is damaged.	Inspect spinner and spinner drive components for alignment and condition. Check for damage to bearings, belts, shafts, and sprockets. Adjust and replace parts as required.
SO.	Spinner drive overload – hardware trip.	Drive belt is misaligned.	
SP	Spinner power issue. No motor present.	Spinner drive motor is not connected. Possible motor defect.	Check connections to the motor (SPIN and GND posts on the module). Replace the motor.

OPERATING THE SPREADER – CAB CONTROL

SETUP PROCEDURES

Calibrate the Empty Hopper Setting (*Cb* and *EH* Codes)

Calibrating the empty hopper setting enables the cab control to alert the operator when the hopper is empty.

Recalibrate the empty hopper setting at the start of each ice-control season.

1. Ensure that the hopper is empty before beginning the calibration.
2. Turn the vehicle ignition to ACC or ON. Press the ON/OFF button on the cab control to turn the control ON.
3. Press and hold the Material Width (left) knob for approximately 10 seconds until the **Cb** code displays.
4. The calibration cycle will begin. The blue LEDs around the Material Flow (right) knob will illuminate in succession until all 8 are lit.
5. When the automatic calibration cycle is complete, the control will automatically revert to the previous material application settings.

If the control is turned OFF or loses power during the calibration cycle, the calibration data will be lost. Make sure the control is ON and restart the calibration process at Step 3.

Once the empty hopper setting has been calibrated, the **EH** code will flash on the display and a beep will sound whenever the hopper is empty. The **EH** code is informational only and will not stop spreader operation.

Clearing Empty Hopper Calibration Data (*Cc* Code)

The empty hopper calibration may be cleared, if desired. The control will no longer display the **EH** status code when the hopper is empty.

Start the calibration cycle as described above. At Step 4, press the Material Flow (right) knob during the calibration cycle to clear *all* calibration data. The **Cc** (Clear Calibration) code will display and the control will exit **Cc** mode automatically.

Adjust LED Brightness Level (*LS* and *SL* Codes)

The brightness setting of the cab control lights can be adjusted from 1 to 16. The factory default setting is 8.

1. Turn the vehicle ignition to ACC or ON. If necessary, press the cab control ON/OFF button to turn the control OFF.
2. Press and hold the Material Width (left) knob for approximately 3 seconds until the **LS** code is displayed.
3. Release the knob and turn it clockwise or counterclockwise to increase/decrease the brightness level. The light level number will show in the status display.
4. After selecting the desired brightness level, wait a few seconds for the **SL** confirmation code to display.

NOTE: A brightness level setting of 12 or higher is recommended for daylight conditions.

OPERATING THE SPREADER

SPREAD PATTERN ADJUSTMENT

The spread pattern and amount of material dispensed depend on hopper chain drive speed, feed gate position and shutter deflector setting.

- Decreasing hopper drive speed and/or gate opening will decrease the amount of material coming to the spinner.
- Increasing hopper drive speed and/or gate opening will increase the amount of material coming to the spinner.

Material spread pattern is directed to left, right or center by the movable shutter deflector. Pull the spring pin located below the spinner, rotate the shutter deflector assembly, and reinsert the pin in the appropriate hole.

- *Spring pin in the left and center-left holes:* Material is directed to the left (driver's) side of the vehicle.
- *Spring pin in the center hole:* Material is directed evenly to both sides of the vehicle.
- *Spring pin in the right and center-right holes:* Material is directed to the right (curb) side of the vehicle.

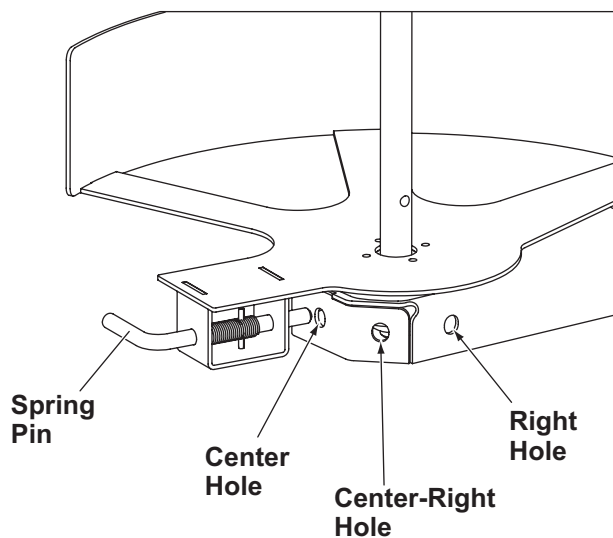
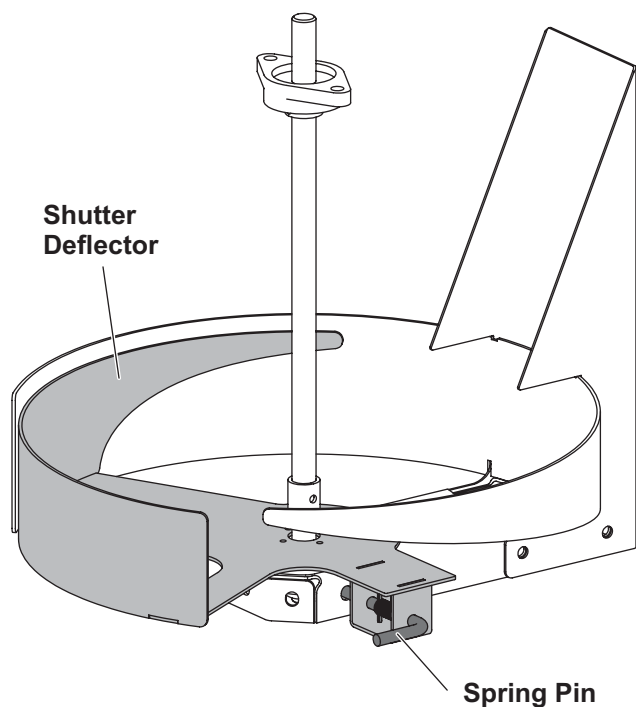

OPERATING THE SPREADER

Material Spread Patterns

Spinner disc not shown.

Spring Pin in
Center Hole

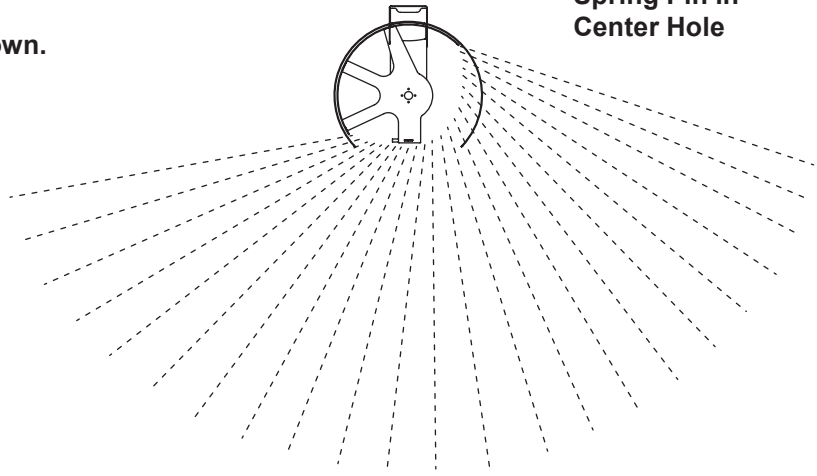

Spring Pin in
Center-Left Hole

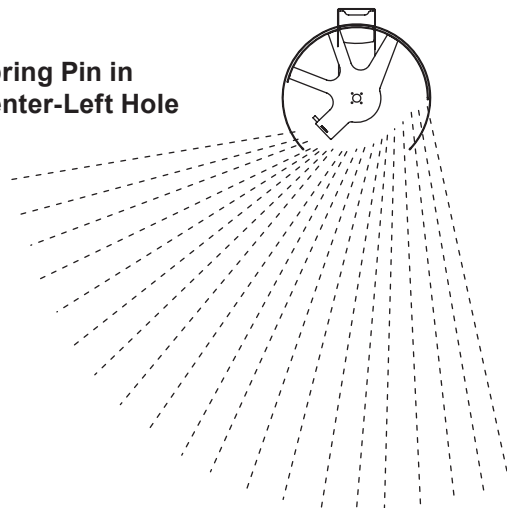

Spring Pin in
Center-Right Hole

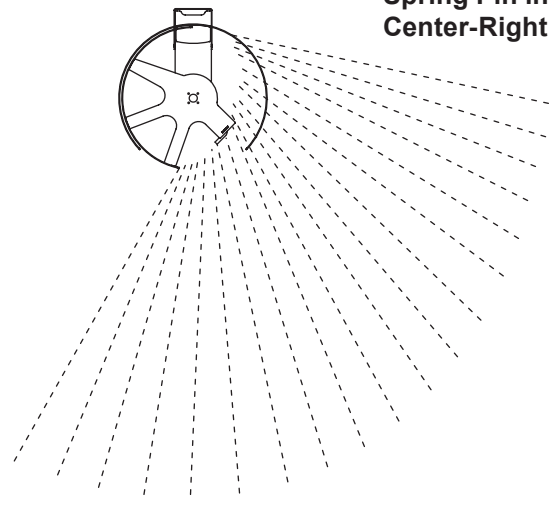

Spring Pin in
Left (Driver's
Side) Hole

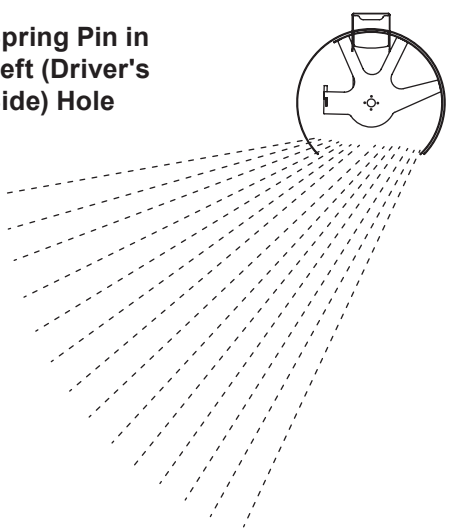

Spring Pin in
Right (Curb
Side) Hole

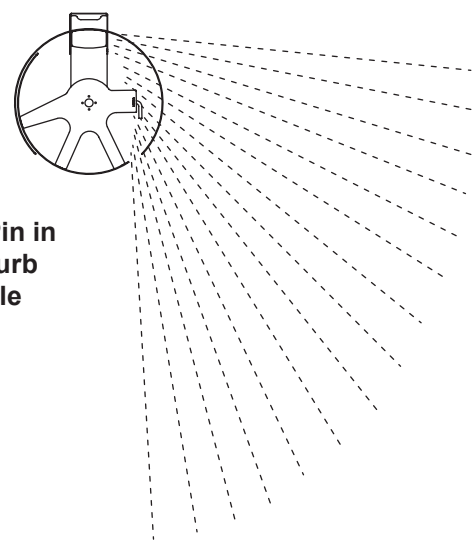

OPERATING THE SPREADER

DUMP FUNCTION

The dump function allows the operator to activate the conveyor to empty the hopper after use or load material into a walk-behind spreader.

The dump function is a two-handed operation requiring the operator to press two buttons at the same time. The conveyor buttons are located on opposite sides of the power box/accessory hub on the chute end of the hopper.

1. Swing the chute to either side or remove it entirely. A magnetic safety switch ensures that the chute spinner motor will not run while the chute is swung to the side.
2. Position the material receptacle or walk-behind spreader under the end of the conveyor.
3. Standing to one side of the conveyor exit, press and hold both buttons to operate the conveyor.

NOTE: Do not stand directly in front of the conveyor when operating the dump function.

4. To stop the conveyor, release one or both buttons.

ACCESSORY WORK LIGHT

Electric-powered spreaders are equipped with a button to operate an accessory work light. The button is on the driver's side of the power box on the chute end of the hopper. The work light can also be turned on and off from the cab control.

The accessory rear lighting package includes a harness, relay, fuse and LED work light. A second LED light and harness can be added as well. Accessory work light kits are available through your authorized dealer.

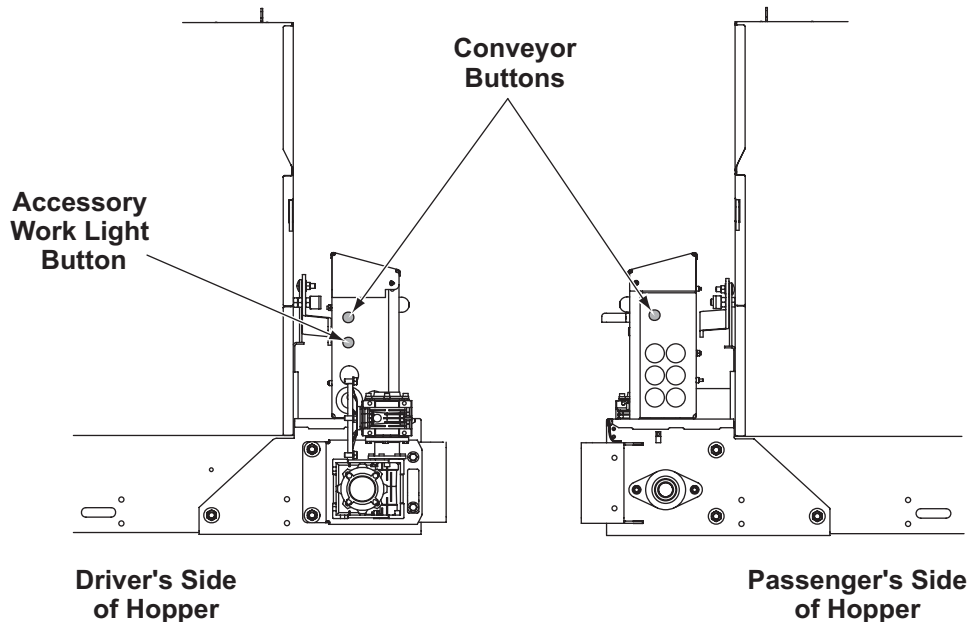

MAINTENANCE

⚠ CAUTION

Disconnect electric power at spreader electrical wiring harness connection and tag out if required before servicing or performing maintenance.

GREASE FITTINGS

To keep your spreader running smoothly, lubricate the grease fittings as shown after each use and at the end of each season.

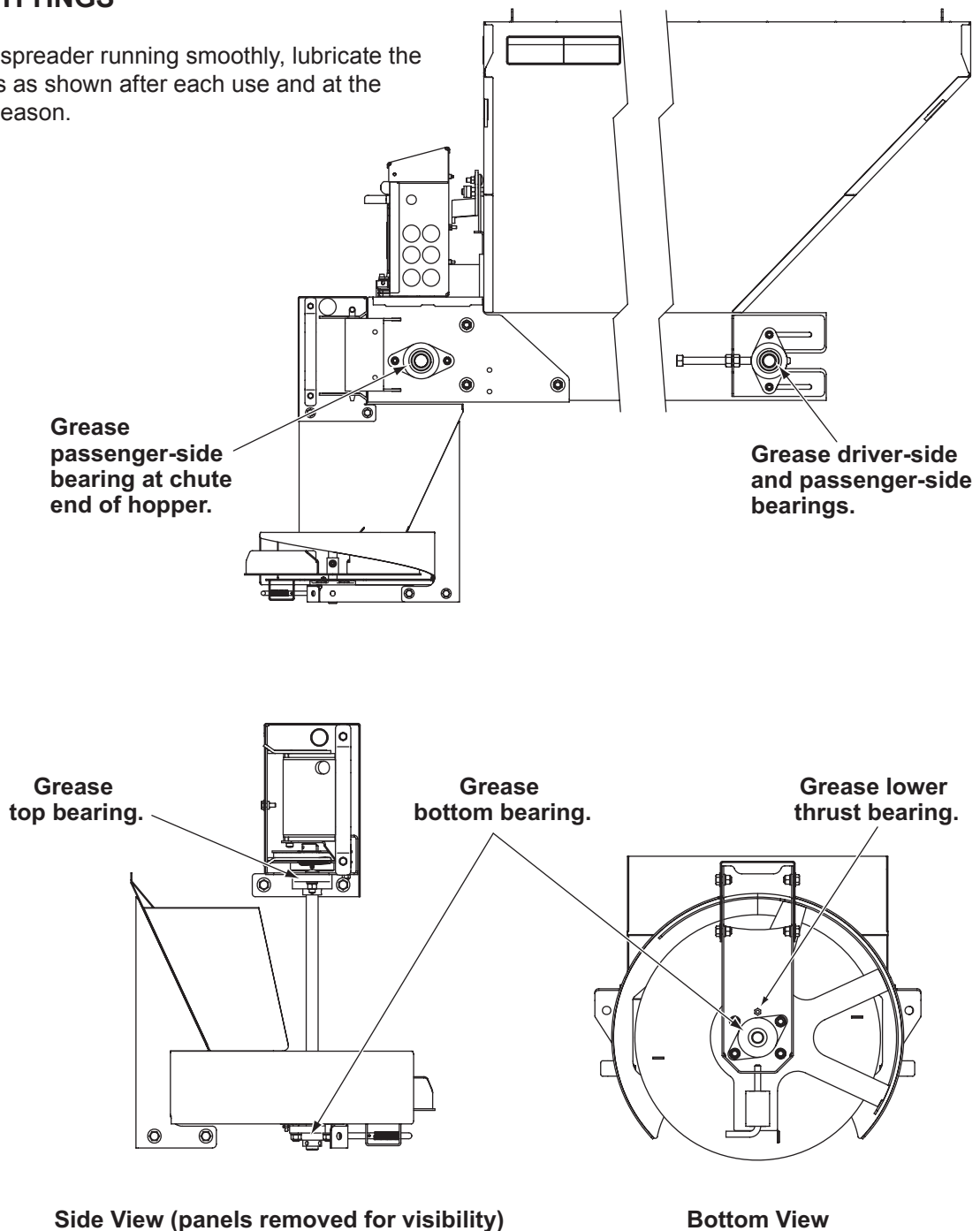

MAINTENANCE

CONVEYOR PINTLE CHAIN TENSION

Periodically check the conveyor chain tension. This procedure is most easily performed when the spreader is outside of the vehicle.

1. The chain should be visible through the chain tension port. You should not be able to push the chain up or down so it goes above or below the hole. The chain should lift up 1" to 3" off the bottom of the chain sill channel. If the slack is greater than 3" and the chain goes past the port, tighten the chain as follows.
2. Loosen the two bearing mounting bolts on each side of the conveyor idle roller at the cab end of the hopper.
3. Loosen the jam nut on one of the idler take-up bolts. Tighten the take-up bolt by turning it clockwise while holding the jam nut. Repeat with the opposite take-up bolt, tightening equally on both passenger's side and driver's side until the chain is in the middle of the chain tension port.

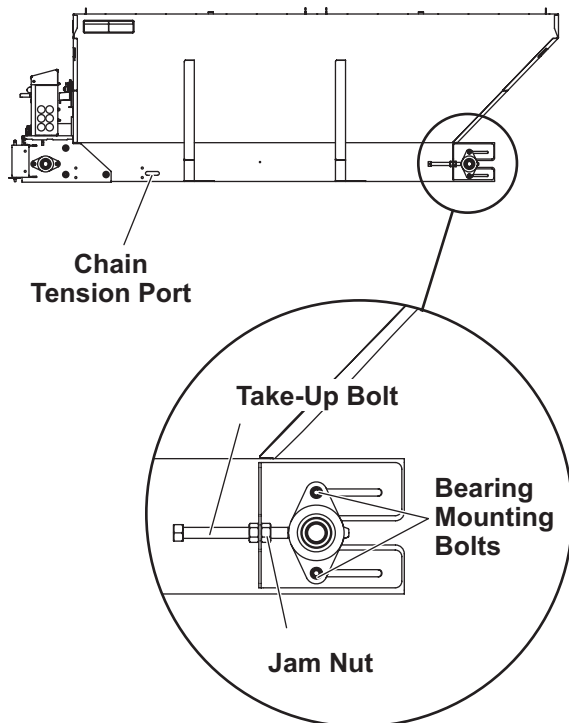

4. Tighten the bearing mounting bolts to 30 ft-lb.

SPINNER BELT ALIGNMENT

Routine inspection of the spinner belt is not required. The chute must be separate from the hopper in order to inspect or adjust the belt alignment.

1. Remove the upper chute section cover plate.
2. Check whether the spinner belt and pulleys are aligned and turn freely.
3. If the spinner belt alignment needs adjustment, loosen the set screw on the motor pulley and adjust the pulley up or down as required.

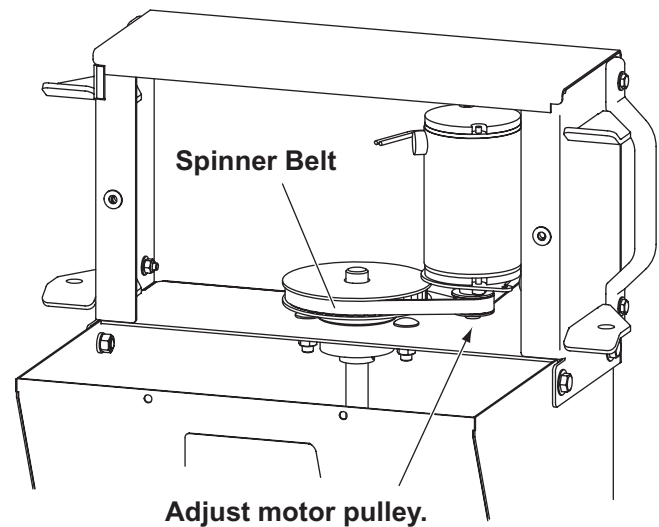

4. Retighten the motor pulley set screw.
5. Reinstall the chute cover plate.

MAINTENANCE

REMOVING THE CHUTE

If the chute must be removed for repair or maintenance:

1. Unplug the chute motor plug from the hopper body (passenger side of the chute).
2. Remove and retain the chute attachment pins.
3. Remove the chute and set it on its side on the ground or work bench. Two people are recommended for this step, as the chute weighs more than 70 lb.

An interlock prevents the feed system from running when the chute is removed.

AFTER EACH USE

⚠ CAUTION

DO NOT leave unused material in hopper. Material can freeze or solidify, causing unit to not work properly. Empty and clean after each use.

- Wash out the hopper and rinse off all external surfaces.
- Clean out any trapped/frozen material from between the pintle chain and the vehicle bed.
- Apply dielectric grease on all electrical connections to prevent corrosion.
- Lubricate all grease fittings with good-quality multipurpose grease.

CAB CONTROL

Unplug the cab control from the control harness at the end of the season or when the hopper is removed from the vehicle.

STORAGE

The spreader can be stored in truck position on blocks or stands. Make sure the supports are stable and the ground beneath is firm enough that the spreader will not shift over time.

⚠ CAUTION

Before lifting, verify that the hopper is empty of material. The lifting device must be able to support the spreader's weight as shown in the spreader specifications table.

1. Remove the chute from the hopper body. Store the chute in a horizontal position. It may be placed inside or on top of the hopper if desired.
2. Remove the hopper mounting bolts and tie-downs.
3. Attach slings to the four corner lift points and, using a hoist, lift the hopper out of the vehicle. Move the spreader to the storage location with the hoist or lower it onto blocks and use a forklift to move it to a secure location.
4. The hopper body should be slightly tilted toward the chute end to prevent any rainwater from pooling in the hopper.
5. Use blocking to ensure that the spreader is stable.

At the End of Each Season Or After Extended Storage

NOTE: The 99067 gearbox is lubricated for life and does not require oil changes.

- Wash out the hopper and rinse off all external surfaces.
- Apply dielectric grease on all electrical connections to prevent corrosion.
- Lubricate all grease fittings with good-quality multipurpose grease.
- Oil or paint any chipped or bare surfaces that are not stainless steel.

FUSE REPLACEMENT

If a problem should occur and fuse replacement is necessary, the replacement fuse must be of the same type and amperage rating as the original. Installing a fuse with a higher rating can damage the system and could start a fire.

RECYCLE

When your spreader has performed its useful life, many of its components can be recycled as steel. Gear oil shall be disposed of according to local regulations.

ELECTRICAL COMPONENTS

VEHICLE HARNESS DIAGRAM

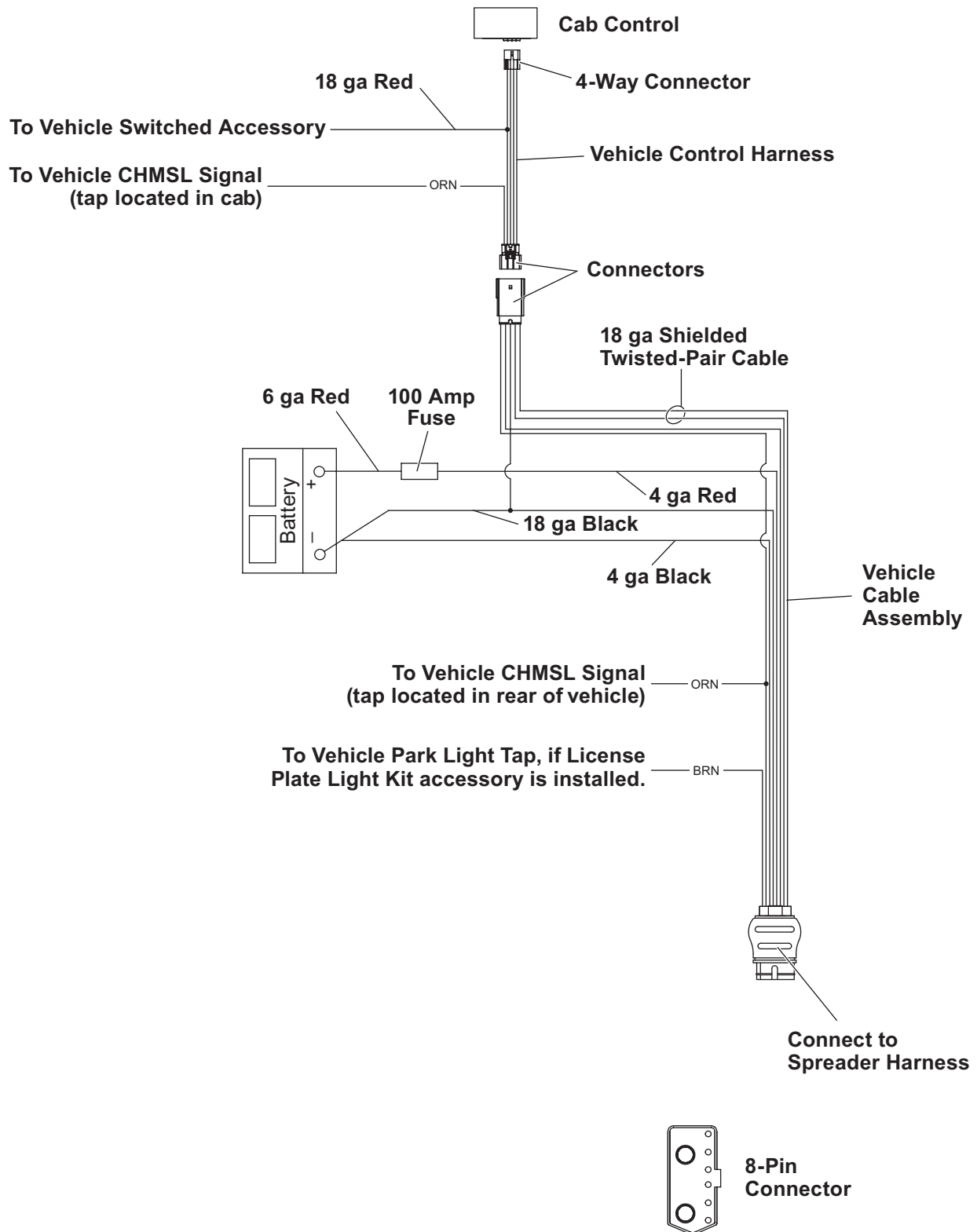

ELECTRICAL COMPONENTS

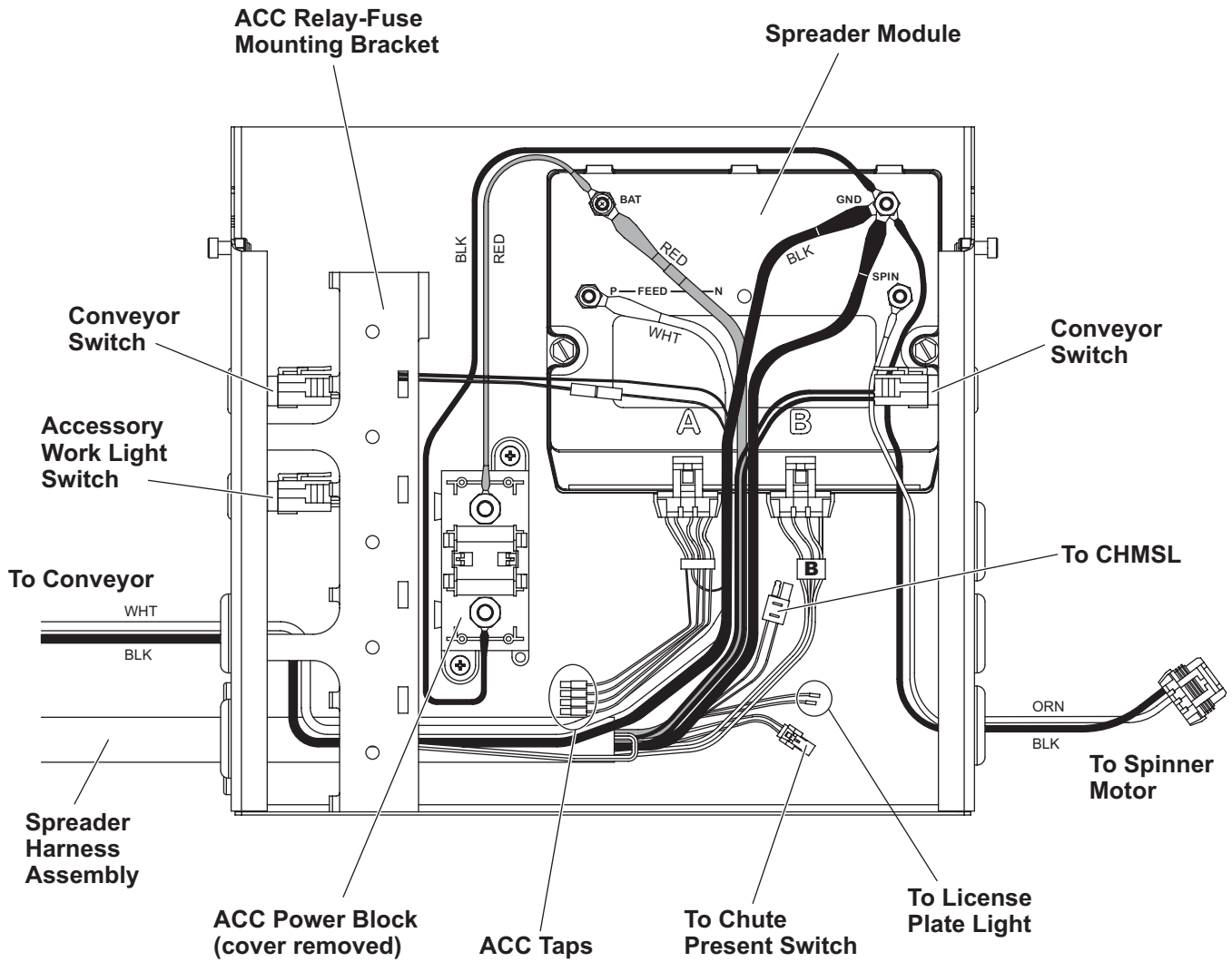

TROUBLESHOOTING GUIDE

Please see your distributor for service. The troubleshooting reference table below may guide you in diagnosing the issue.

For a reference table of the cab control error codes, see the "Operating the Spreader – Cab Control" section of this manual.

Before servicing the spreader:

- Review all safety information.
- Confirm that all electrical connections are tight and clean.
- Confirm that nothing is jammed in the hopper.

Problem	Possible Cause	Suggested Solution
No power to cab control. Ignition and control switches ON; control knob indicator lights not illuminated.	1. Control is in Standby mode. Spreader is not connected.	1. Press any button on control to wake.
	2. Control connector plug is loose.	2. Check plug connection at cab control.
	3. Switched accessory connection is poor or faulty battery.	3a. Check for low battery. 3b. Check switched accessory connection.
	4. Blown fuse.	4. Replace spreader vehicle battery cable fuse.
	5. Vehicle control harness is damaged.	5. Repair or replace damaged wires or harness as required.
Turning control knobs does not change motor speed.	1. Malfunctioning cab control.	1. Replace cab control.
	2. Malfunctioning spreader module.	2. Replace spreader module.
Spreader does not operate.	1. Overloaded condition is causing over-current protection to activate.	1. Reset cab control by pressing the ON/OFF switch.
	2. Wire harness is damaged or has an open circuit between cab control and spreader.	2a. Check plug connections at cab control and spreader. 2b. Check wire connections at spreader motor and at vehicle battery: disconnect motor leads, turn Material Width and Material Flow knobs to maximum, and check for voltage at motor leads. 2c. Repair or replace damaged wires and connectors. 2d. Check the 100 A in-line fuse on the 22" red cable. Replace if necessary.

TROUBLESHOOTING GUIDE

Problem	Possible Cause	Suggested Solution
Spinner does not turn. Motor is running.	Unplug the spreader harness and tag out, if required, before performing any of the following repairs.	
	1. Obstruction is preventing rotation.	1. Clear obstruction.
	2. Drive belt is loose or damaged.	2. Adjust the tension or replace the belt if worn or damaged.
	3. Motor pulley not secured to motor shaft.	3. Tighten the pulley set screw or replace the pulley if damaged.
	4. Spinner pulley is not secured to spinner shaft.	4. Tighten the pulley set screw or replace the pulley if damaged.
	5. Spinner shaft bearings are dry or seized.	5. Grease or replace bearings.
Conveyor chain not moving. Spinner is turning.	Unplug the spreader harness and tag out, if required, before performing any of the following repairs.	
	1. Obstruction is preventing rotation.	1. Clear obstruction.
	2. Gear box is damaged.	2. Replace gear box if output shaft does not turn when motor shaft turns.
	3. Conveyor sprockets are not secured to shafts.	3. Replace or tighten set screws. Replace shafts or sprockets if damaged.
	4. Conveyor pintle chain is loose or damaged.	4. Adjust pintle chain tension. Replace pintle chain if damaged.
	5. Conveyor pintle chain is not aligned.	5. Align pintle chain to ride centered on rollers.
Material in hopper does not flow. Conveyor pintle chain and spinner are moving.	Unplug the spreader harness and tag out, if required, before performing any of the following repairs.	
	1. Feed gate is closed.	1. Open feed gate fully, and then adjust to desired opening size.
	2. Obstruction in hopper.	2. Clear obstruction.
	3. Material bridged.	3. Clear the bridged material.

This page intentionally left blank.

This page intentionally left blank.



Fisher Engineering
50 Gordon Drive
Rockland, ME 04841-2139
www.fisherplows.com

A DIVISION OF FISHER, LLC



This product conforms to EU Machinery Directive 2006/42/EC and Directive 2011/65/EC (RoHS2).

Copyright © 2017 Douglas Dynamics, LLC. All rights reserved. This material may not be reproduced or copied, in whole or in part, in any printed, mechanical, electronic, film or other distribution and storage media, without the written consent of Fisher Engineering. Authorization to photocopy items for internal or personal use by Fisher Engineering outlets or spreader owner is granted.

Fisher Engineering reserves the right under its product improvement policy to change construction or design details and furnish equipment when so altered without reference to illustrations or specifications used. Fisher Engineering or the vehicle manufacturer may require or recommend optional equipment for spreaders. Do not exceed vehicle ratings with a spreader. This product is manufactured under the following U.S. patents: 7,400,058; 7,737,576, and other patents pending. Fisher Engineering offers a limited warranty for all spreaders and accessories. See separately printed page for this important information. The following are registered (®) or unregistered (™) trademarks of Douglas Dynamics, LLC: FISHER®, STEEL-CASTER™.

Printed in U.S.A.