

**REDI-DEK™**



— NO BODY BETTER —



Made in  
the USA



**REDI-DEK™**  
VERSATILE OPTION PACKAGES

# SL BODY



- 1 Side Rails** - Outside stake pockets with 2" steel tie-down rails, dirt shedding return bend
- 2 Steel Tubular Tapered Bulkhead** - Horizontal slats protecting rear window. Includes stop, turn, tail and work lights
- 3 Rear Apron** - Steel diamond plate, with recessed and rubber isolated LED stop, turn, reverse and clearance lights
- 4 Alumina-Fill® Fuel Fill** - Recessed in side rail with multiple locations provided for various fill requirements
- 5 E-coat and Powder Coat Finish** - Corrosion resistant prime application and durable abrasion resistant black powder coat finish for long lasting durability
- 6 Steel Treadplate Floor** - Square corners for maximum deck space

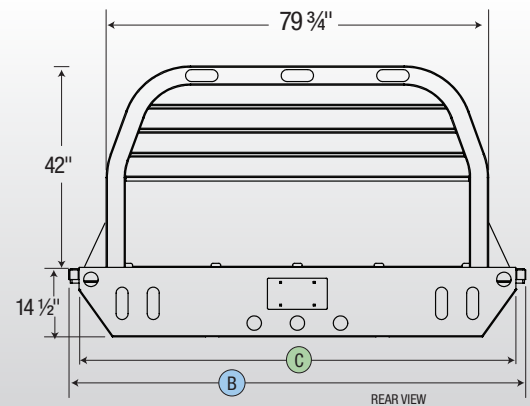
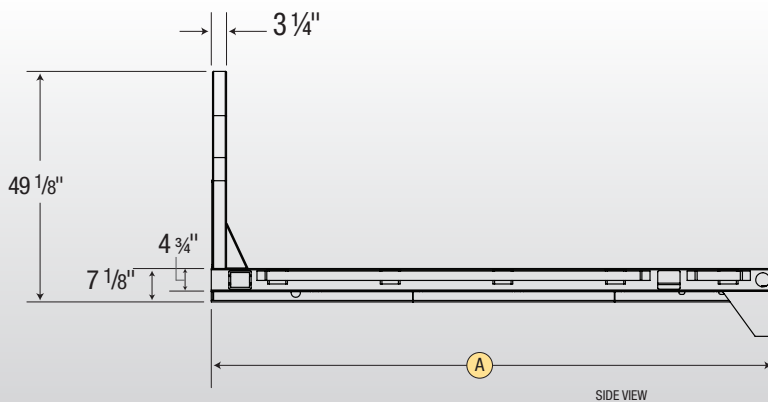

## DIMENSIONAL DATA: REDI-DEK SL

Model	A	B	C	Cab to Axle	Approx. weight
RDK-8.5SW	102"	84.75"	80.62"	56"	640 lbs.
RDK-10DW	120"	95.25"	91.12"	60"	790 lbs.
RDK-12DW	144"	95.25"	91.12"	84"	885 lbs.





# TOW & HAUL BODY



All standard features of the SL body are included plus:

- 1** **Gooseneck Ball Hitch Door** - Easy lift-n-slide access door closes for a flat surface when not in use
- 2** **Tapered Corners (DW Models Only)** - Provides better trailer clearance
- 3** **Rear Hitch (DW Models Only)** - 2" receiver, 16,000 lb rating; trailer plug hole with safety chain



Chassis specific hitch available

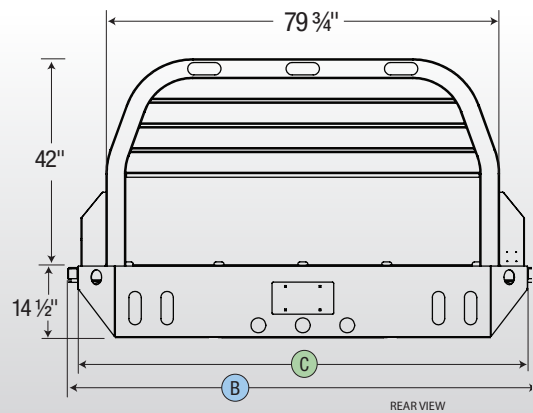
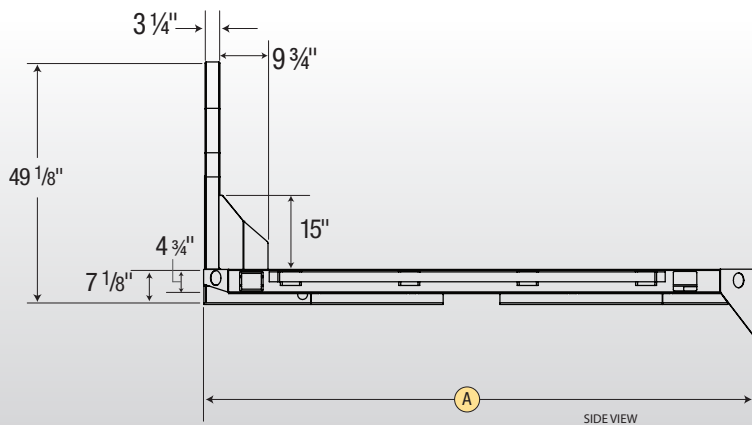

## DIMENSIONAL DATA: REDI-DEK TOW & HAUL

Model	A	B	C	Cab to Axle	Approx. weight
RDKG-8.5SW	102"	84.75"	80.62"	56"	710 lbs.
RDKG-9DW	112"	95.25"	91.12"	60"	880 lbs.
RDKG-11DW	136"	95.25"	91.12"	84"	1010 lbs.

# CONTRACTOR BODY



All standard features of the SL body are included plus:

- 1 Storage Boxes** - Two 96" steel or aluminum Tool Mates mounted on top of the deck for secure storage
- 2 Sides** - 16" high drop down sides at the rear of the tool boxes for easy side loading
- 3 Tailgate** - Drop-down rear tailgate with heavy-duty restraining chain on each side

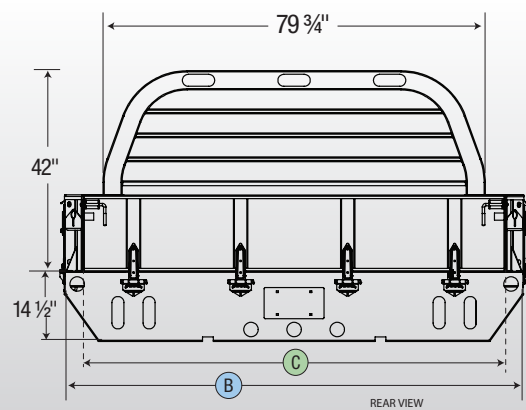
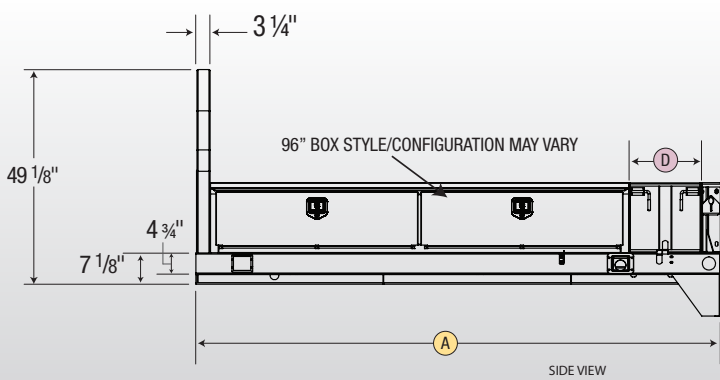

## DIMENSIONAL DATA: REDI-DEK CONTRACTOR

Model	A	B	C	D	Cab to Axle	Approx. weight
RDKC-10DW	120"	95.25"	87.75"	16"	60"	900 lbs.
RDKC-12DW	144"	95.25"	87.75"	40"	84"	1050 lbs.



— NO BODY BETTER —



Redi-Dek™ is the perfect pickup bed replacement, with a compact platform ideal for securely hauling equipment and light machinery. Versatile option packages include SL Body, Tow & Haul Body and Contractor Body. Each model comes with Reading's 3-year limited warranty.

## OPTIONS Add on to any Redi-Dek model, customizing to your storage needs.

### Underbody Boxes

Model	Length	Approx Ship Weight	
		Steel	Aluminum
U-24	24"	61 lbs.	33 lbs.
U-30	30"	72 lbs.	41 lbs.
U-36	36"	82 lbs.	44 lbs.
U-48	48"	104 lbs.	55 lbs.

*"U" Models available in black or white powder coat.  
Boxes also available in Aluminum. To order, add "AL" to the model number.  
Underbox height is 18", depth 18"*



### Overhead Material Rack

- Universal design rack fits the Redi-Dek bodies from 8.5' single wheel up to and including 12' dual wheel bodies
- Constructed from 1/8" thick, high-strength steel square tubing, 1-1/2" x 1-1/2" and 2" x 2"
- Horizontal cross bars with storage cradles
- Notched gusset supports provide tie down anchor points
- Built-in front wind deflector provides noise reduction
- Zinc phosphate steel preparation and durable semi-gloss black vinyl dip finish coat
- 1,000 lb. capacity
- Optional 11" extension available for taller cabs

**FOCUSED** | COMMITTED | INNOVATIVE



# READING HAS A FULL LINE OF TRUCK BODIES TO CHOOSE FROM ...



Classic II Service Body – Steel



Classic II Service Body – Aluminum



Classic Service Van - Aluminum



SL Service Body



Panel Body



Ready Van SL – Steel



Cranemaster 3200 Body



Platform Body



Marauder Dump Body



Redi-Dek Body



Landscaper SL Body



Redi-Rack Body



Marauder SL Dump Body



Drop Side Dump Body



Stake Body



Custom Body



— NO BODY BETTER —

All dimensions subject to plus or minus tolerance of 1/4" and all dimensions and specifications are subject to change without notice. Some items displayed in photographs are optional. Alumina-Fill, Alumina-Chock, Dual-Pro, Extend-A-Shelf, Grip-n-Glide, Latch-Matic, Marauder, Reading, Redi-Dek, Rhino Linings, Rugged American, S.M.A.R.T Racks, Spacemaker, Tool-Mates, and TUFF STUFF are registered trademarks of The Reading Group, LLC in the United States and some foreign countries. The Reading Kangaroo is a trademarked image and may not be reproduced or used without express permission from The Reading Group.

