



CLASSIC II SERVICE BODIES



— NO BODY BETTER —



Made in  
the USA



CLASSIC II SERVICE BODIES

STEEL AND ALUMINUM 





# STANDARD FEATURES

Our flagship Reading service body is the product of more than 60 years of refinement, and it shows. Available in rugged steel or fuel-saving aluminum, our service truck bodies offer a wealth of exclusive features and options. The result is a service body that you can truly make your own—and will serve you well for many miles down the road.



Model shown with available options

Available with E-Coat prime & powder coated finish, A60 coating weight steel construction.

- 1 Patented Hidden Hinges** – Industry-exclusive overlapping door construction resists forcible entry. Robust, concealed hinge design provides protection against corrosion without requiring frequent lubrication or maintenance. Fully adjustable and easily replaced without damage to body or door.
- 2 Slam Action Tailgate** - Features a polished, stainless steel handle and double-panel construction. Stainless steel locking rods, hinge rods and striker channels.
- 3 Pooched, Frame-Mounted Bumper** – Prevents body damage and provides slip-resistant step surface. E-coat prime and white powder coat finish.
- 4 Nitrogen Strut Door Holders** - All vertical compartment doors are equipped with nitrogen strut door holders. Internal dampeners control the opening and closing of doors.
- 5 LED Lights** - Rubber isolated seal for improved leak resistance.
- 6 Heavy-Duty Compartment Doors** – Double-panel construction with internal reinforcement for added strength.
- 7 Exclusive Dual-Pro® Door Seal System** – Large, automotive quality bubble-type seal and mechanical seal provide a dual line of defense against weather. Patented design increases clear door openings in every compartment of the body.
- 8 Stainless Steel Rotary Locks** – Attractive appearance with no exposed fasteners; rust resistant. Features a double-bitted, high-quality locking cylinder; adjustable striker pins; and an O-ring seal to prevent water intrusion.
- 9 Galvanized Shelves** – Designed with 2" dividers for more small item storage. Full access between all vertical compartments for longer tool storage.

## OTHER STANDARD FEATURES



**A60 Coating Weight Pressed Diamond Plate Floor and Tailgate Face Plate** - Industry exclusive surface provides additional corrosion protection and better traction.



**Aluma-Fill®** – Fuel receptacle protects the body and finish from accidental nicks and scratches.

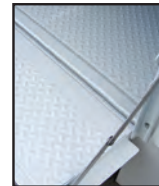

**Removable Stainless Steel Tailgate Knee Braces** - Allow the tailgate to swing down flush with the bed surface.

# ALUMINUM SERVICE BODIES

## Better fuel economy. Increased payload capacity.

The Aluminum Classic II offers an unbeatable combination of standard features, useful options, and the know-how of over 30 years of refinement. This service body is designed for efficiency today, and built to last for tomorrow.

## Real Truck Value, by the Numbers

50%

LIGHTER THAN  
ANY STEEL OR  
FRP BODY

UP  
TO

10%

FUEL  
SAVINGS\*

\*Actual fuel savings will vary based  
on chassis weight and payload weight

100%

READING RUGGED

- INCREASED payload capacity
- LESS WEAR and tear on chassis
- GREATER residual value at the end of life cycle
- INHERENTLY corrosion resistant
- EASILY recycled

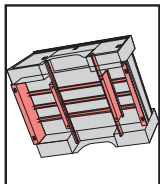

### Rugged Understructure

Fully unitized welding, with U-beam girders braced and reinforced at all critical points.

**RUGGED | SUSTAINABLE | RESPONSIBLE**

# AVAILABLE OPTIONS



## Powder Coating

- Polyester powder is sprayed on the body, then baked to form a highly durable finish
- Resistant to corrosion, chemicals, humidity, scratches, chips, and impact
- Brighter finish
- Tolerant of UV exposure



## Latch-Matic® with Optional Audible Alarm System

- One touch simultaneously locks or unlocks all compartments on the body
- Two high quality key fob transmitters with 25' range
- Optional audible alarm is enabled by locking doors with the key fob transmitter
- Proven, automotive quality components with concealed wiring and hardware
- Compartment doors can be locked individually with keys (provided)
- Three-year limited warranty on parts and service



## Compartment Lighting System

- Works in conjunction with the Latch-Matic system, activating lights when compartment doors are locked and unlocked
- Programmed to go off automatically after 10 minutes
- Lights feature impact resistant lenses
- Additional light for cargo bed also available

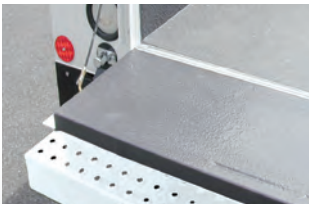

## Spray On Bedliner

- Available as a factory-installed option
- Offers watertight and airtight truck bed protection
- Prohibits rust, corrosion and surface abrasion while providing a slip resistant surface



## Master Locking

- Steel slide bar simultaneously locks all of the side compartment doors
- Spring loaded for easy manual operation

## The C2-60 Options Package

This Classic II can be equipped with the C2-60 package, a group of our most popular and most exclusive options.



### Latch-Matic® C2-60

Remote locking system with audible confirmation and security alarm also activates lighting.



### Aluminum Treadplate

Protective guards on front of body panels and on top of tailgate.



### LED Lighting

Compartment and cargo bed lighting activated by the security system. LED also used for stop/tail/turn/reverse lights.



### Ergo Glide-N-Lock Drawers™

Modular compartment drawer system provides easy pull-out access to contents.

---

## Bumpers

Reading bumpers are constructed of heavy-duty A60 coating weight steel and are protected by acrylic E-Coat priming. They are offered in a wide array of styles and feature deck plate, poached, or all-weather slip resistant surfaces.

Available only on certain models.



Single Wheel Bumper with LED lights



Dual Wheel Bumper with LED lights



Single Wheel Recessed Bumper with LED lights



Dual Wheel Recessed Bumper with LED Lights

## Steel Equipment

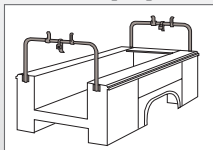

Removable Overhead Ladder Rack

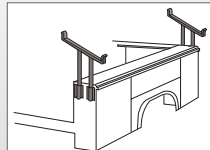

Removable Side Mount Ladder Rack (Angular Rack Shown, Flat Rack Also Available)

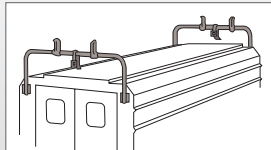

Removable Overhead Ladder Rack for Panel Body

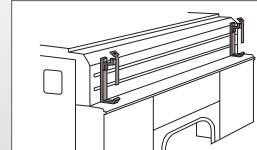

Side Mount Ladder Rack for Panel Body

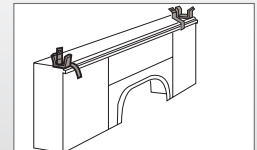

Pipe Vise Rack

**DEPENDABLE** | DURABLE | RUGGED | VERSATILE

# CLASSIC II MODEL

## Standard Service Bodies

- Single and dual wheel configurations
- Available in 78", 82", 98", 108", and 132" sizes
- Protected by acrylic E-Coat priming and powder coat finish on steel models

### Standard Service Body

108SW ("A" side shown) with recessed tail lights and optional independently mounted poched bumper



## STANDARD BODIES

Model	Approx. Wt.		Cab-to-Axle	A	B	C	D	Approx. Compartment Clear Door Openings			J	L	M
	Steel	Alum.						E	F	G			
**78-SWs	882 lbs.	453 lbs.	40"	18"	42"	18"	78"	12-1/2"x33-3/8"	40-1/2"x11-7/8"	12-1/2"x33-3/8"	9"	24"	40"
*82-SWs	969 lbs.	522 lbs.	40"	17"	42"	23"	82"	11-1/2"x33-3/8"	40-1/2"x11-7/8"	17-1/2"x33-3/8"	9"	24"	40"
U98-SWs	1046 lbs.	543 lbs.	56"	28"	47"	23"	98"	22-1/2"x33-3/8"	45-1/2"x11-7/8"	17-1/2"x33-3/8"	9"	24"	40"
98-DWs	1164 lbs.	604 lbs.	56"	28"	47"	23"	98"	22-1/2"x33-3/8"	45-1/2"x11-7/8"	17-1/2"x33-3/8"	9"	24"	40"
U108-SWs	1045 lbs.	595 lbs.	60"	33"	47"	28"	108"	27-1/2"x33-3/8"	45-1/2"x11-7/8"	22-1/2"x33-3/8"	9"	24"	40"
U108-DW	1251 lbs.	656lbs.	60"	33"	47"	28"	108"	27-1/2"x33-3/8"	45-1/2"x11-7/8"	22-1/2"x3-3/8"	9"	24"	40"

### Installers Notes:

- \* 2017 Ford Super Duty chassis only
- \*\* E-Z mounting installation not available on these models
- s Equipped with spring shackle offsets. Dimensions are 12 3/4" h x 4" deep.

## STANDARD BODY DIAGRAMS

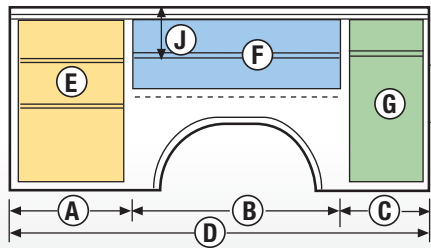

"A" Compartment Layout

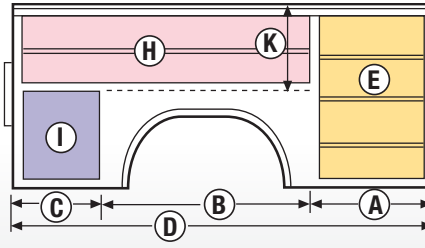

"B" Compartment Layout

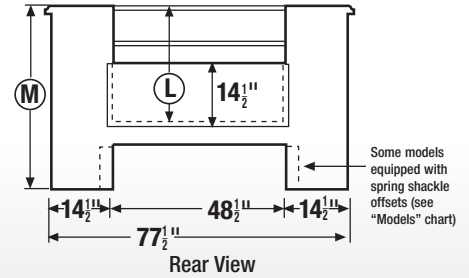

Rear View

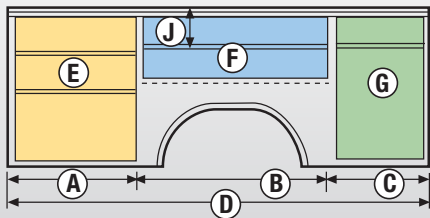

"A" Compartment Layout

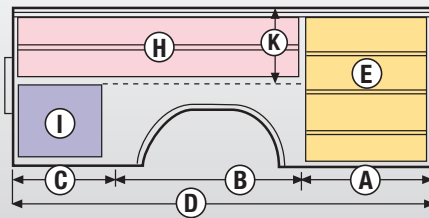

"B" Compartment Layout

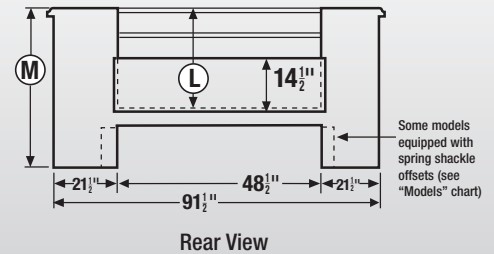

Rear View

### Standard Shelf and Divider Equipment

All shelves removable, all dividers removable and adjustable. Dividers interchangeable on most shelves.

### All Models Available With:

"A" compartment layout both sides. Combination "AB" with "A" layout on roadside and "B" layout on curbside. Bumpers are optional at additional cost



# CLASSIC II SPACEMAKER® MODEL



## Spacemaker® Service Bodies

- Feature top-opening compartments that provide 15% more storage space
- Reinforced lids feature two pneumatic props and rotary catches with push button release
- Protected by acrylic E-Coat priming and powder coat finish on steel models
- Available in same configurations and sizes as standard bodies

## SPACEMAKER® BODIES

Model	Approx. Wt.		Cab-to-Axle	A	B	C	D	Approx. Compartment Clear Door Openings			J	L	M
	Steel	Alum.						E	F	G			
**S78-SWs	1018 lbs.	560 lbs.	40"	18"	42"	18"	78"	12-1/2"x33-3/8"	40-1/2"x11-7/8"	12-1/2"x33-3/8"	10"	24"	41-1/2"
*S82-SW	1081 lbs.	580 lbs.	41"	17"	42"	23"	82"	11-1/2"x33-3/8"	40-1/2"x11-7/8"	17-1/2"x33-3/8"	10"	24"	41-1/2"
S98-SWs	1189 lbs.	654 lbs.	56"	28"	48"	22"	98"	22-1/2"x33-3/8"	45-1/2"x11-7/8"	17-1/2"x33-3/8"	10"	24"	41-1/2"
S98-DWs	1377 lbs.	757 lbs.	56"	28"	48"	22"	98"	22-1/2"x33-3/8"	45-1/2"x11-7/8"	16-1/2"x33-3/8"	10"	24"	41-1/2"
US108-SWs	1307 lbs.	719 lbs.	60"	33"	47"	28"	108"	27-1/2"x33-3/8"	45-1/2"x11-7/8"	22-1/2"x33-3/8"	10"	24"	41-1/2"
US108-DW	1442 lbs.	793 lbs.	60"	33"	47"	28"	108"	27-1/2"x33-3/8"	45-1/2"x11-7/8"	22-1/2"x33-3/8"	10"	24"	41-1/2"

### Installers Notes:

- \* 2017 Ford Super Duty chassis only
- \*\* E-Z mounting installation not available on these models
- s Equipped with spring shackle offsets. Dimensions are 12 3/4" h x 4" deep.

## SPACEMAKER BODY DIAGRAMS

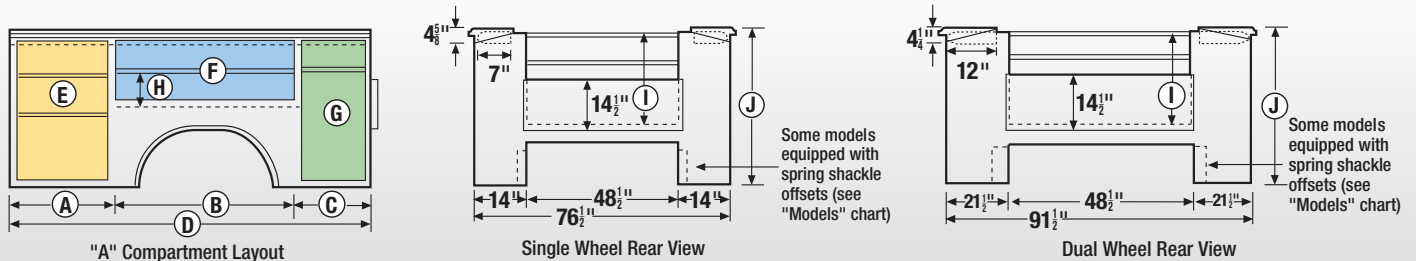

### Standard Shelf and Divider Equipment

All shelves removable, all dividers removable and adjustable. Dividers interchangeable on most shelves.

### All Models Available With:

"A" compartment layout both sides. Combination "AB" with "A" layout on roadside and "B" layout on curbside. Bumpers are optional at additional cost



# 132 BODIES

Model	Approx. Wt.	Cab-to-Axle	Approx. Clear Door Openings			
			A	B	C	D
U132-DW	1502 lbs.	84"	27-1/2"x33-3/8"	17-1/2"x33-3/8"	45-1/2"x11-7/8"	22-1/2"x33-3/8"
US132-DW	1757 lbs.	84"	27-1/2"x33-3/8"	17-1/2"x28-3/8"	45-1/2"x11-7/8"	22-1/2"x33-3/8"

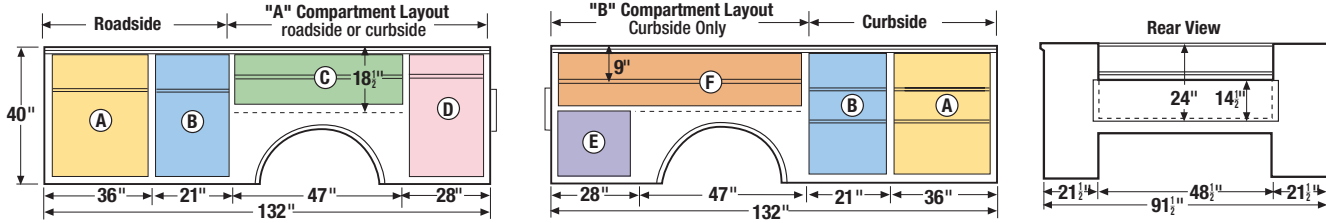

Optional crane reinforcement available at added cost upon request. Reading also manufactures "Cranemaster" bodies which are specifically engineered for crane use. Capacity restrictions may apply.

### Standard Shelf and Divider Equipment

All shelves and dividers removable and adjustable.

# STEEL SLIDING TOPS

Model	For Body	Approx. Wt.		A	B	C	D	E
		Steel	Alum.					
ST-78	78SW	145 lbs.	80 lbs.	40-1/4"	37-1/4"	—	77-1/2"	50-7/8"
ST-98	98SW/DW	155 lbs.	86 lbs.	49-3/4"	47-3/4"	—	102"	50-7/8"
ST-108	108SW/DW	170 lbs.	95 lbs.	55-1/4"	52-1/4"	—	107-1/2"	50-7/8"
ST-108HD	HD-108	225 lbs.	—	55-1/4"	53-7/8"	107-1/2"	52-3/8"	—
ST-120HD	HD-120	350 lbs.	—	40-3/4"	40-3/4"	40"	119-3/4"	52-3/8"
ST-132HD	HD-132	370 lbs.	—	44-3/4"	44-3/4"	44"	131-3/4"	52-3/8"
ST-150HD	HD-150	410 lbs.	—	50-3/4"	50-3/4"	50"	149-3/4"	52-3/8"

- Available in two or three sections (depending on body size)
- Slides on full-length galvanized steel tracks
- Secured with a two-point positive action stainless steel T-handle lock

Models  
ST78 – ST108HD

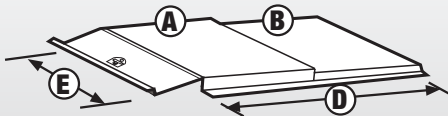

Models  
ST120HD – ST150HD

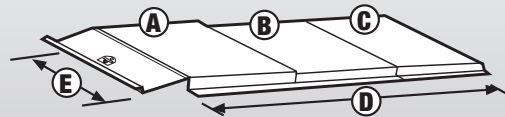

**DEPENDABLE** | DURABLE | RUGGED | VERSATILE



# HEAVY-DUTY BODIES

Model	Approx. Wt.	Cab-to-axle	Approx. Compartment Clear Door Openings				
			A	B	C	D	E
HD108	1414 lbs.	60"	29-1/4"x38-1/2"	45-1/2"x14"	20-3/4"x38-1/2"	—	—
HD120	1761 lbs.	72"	36-1/2"x38-1/2"	48-1/2"x14"	20-3/4"x38-1/2"	—	—
HD132	2182 lbs.	84"	22-1/2"x38-1/2"	48-1/4"x14"	20-3/4"x38-1/2"	35"x21-3/8"	11-1/2"x38-1/2"
HD150	2536 lbs.	102"	20-1/2"x38-1/2"	48-1/4"x14"	20-3/4"x38-1/2"	—	—

Heavy-duty bodies are designed for chassis 1½ ton and over with dual rear wheels

## HD108

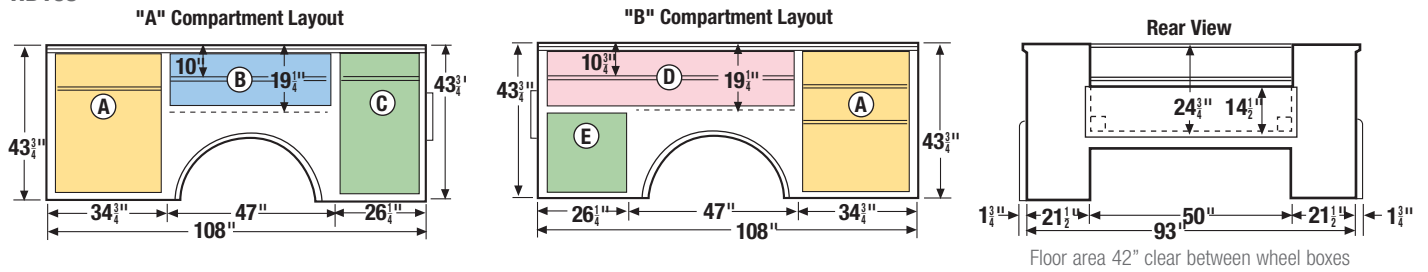

## HD120

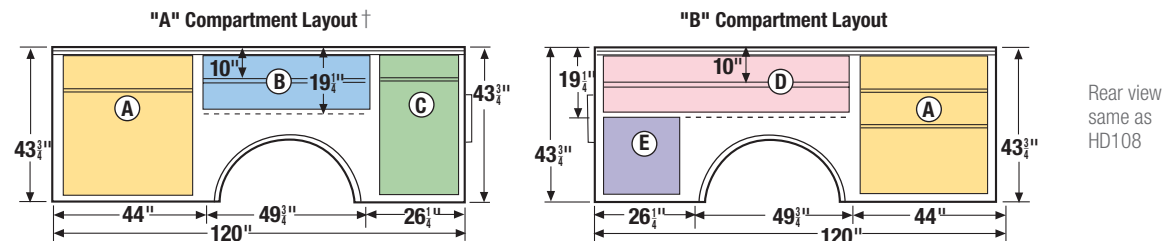

## HD132

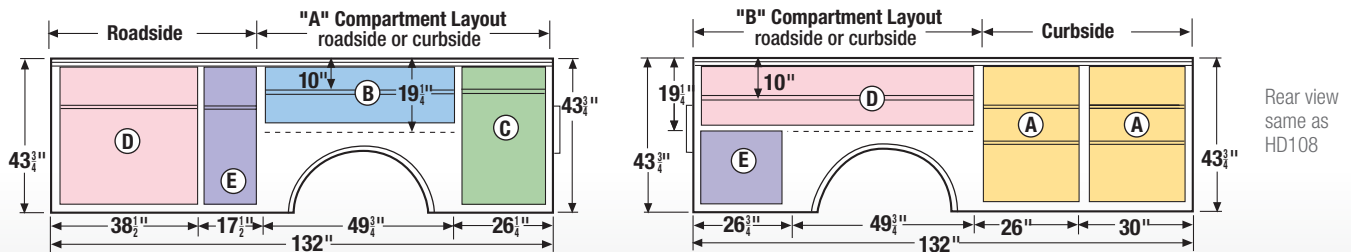

## HD150

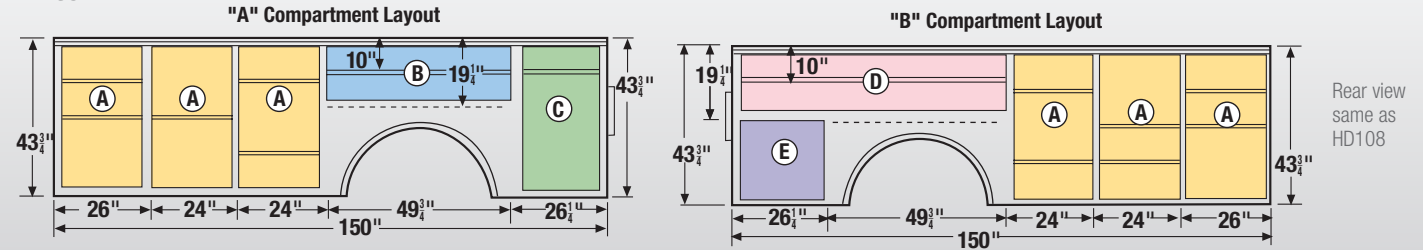

### Standard Shelf and Divider Equipment

All shelves removable, all dividers removable and adjustable. Dividers interchangeable on most shelves. Optional crane reinforcement available at added cost upon request. Capacity restrictions may apply.

# ENCLOSURES FOR CLASSIC II™ BODIES

Need a service body with an enclosed work space? Reading Enclosed Bodies are the answer. Equipped with spacious outside storage compartments and featuring a completely enclosed cargo and work area, Reading enclosed bodies offer the best of both worlds.

## Panel Bodies

- Rear doors close and lock securely with 2-point locking system
- Available in galvanized steel or fuel-saving aluminum
- Protected by acrylic E-Coat priming and powder coat finish
- Enclosed area has full length shelves on each side to provide carrying space for long-handled tools and equipment



**108SW Tapered Panel Body 60 Series**  
(Ladder rack, grab handle and foot step are optional)

## PANEL BODIES

Dimensions and specifications for lower compartment areas correspond to Reading service bodies with equivalent model numbers (minus prefix TPA-50, TPA-60, or TPA-72) shown below.

50 Series – 50" inside head clearance						
Model	Approx. Wt.*		Dimensions			
	Steel	Alum.	A	B	C	Length
TAPERED PANEL TOPS						
TPA50-98SW**	565 lbs.	291 lbs.	63-1/2"	6-1/4"	48-1/2"	98"
TPA50-108SW**	602 lbs.	310 lbs.	63-1/2"	6-1/4"	48-1/2"	108"
TPA50-108DW	595 lbs.	287 lbs.	73-1/2"	11-1/4"	48-1/2"	108"

60 Series – 60" inside head clearance						
Model	Approx. Wt.*		Dimensions			
	Steel	Alum.	A	B	C	Length
TAPERED PANEL TOPS						
TPA60-98SW**	643 lbs.	330 lbs.	63-1/2"	6-1/4"	48-1/2"	98"
TPA60-98DW	735 lbs.	—	73-1/2"	11-1/4"	48-1/2"	98"
TPA60-108SW**	684 lbs.	357 lbs.	63-1/2"	6-1/4"	48-1/2"	108"
TPA60-108DW	783 lbs.	—	73-1/2"	11-1/4"	48-1/2"	108"
TPA60-132DW	938 lbs.	466 lbs.	73-1/2"	11-1/4"	48-1/2"	132"

72 Series – 72" inside head clearance						
Model	Approx. Wt.*		Dimensions			
	Steel	Alum.	A	B	C	Length
TAPERED PANEL TOPS						
TPA72-108DW	986 lbs.	—	73-7/8"	11-1/2"	48-1/2"	108"
TPA72-132DW	1178 lbs.	590 lbs.	75"	12"	48-1/2"	132"

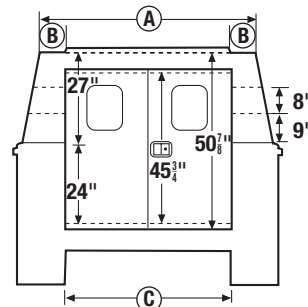

Rear View  
**50 Series (TPA)**

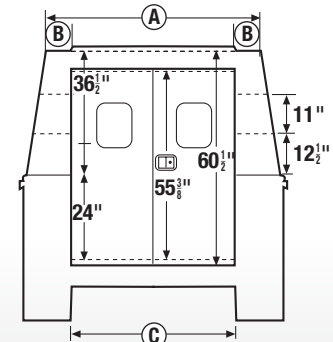

Rear View  
**60 Series (TPA)**

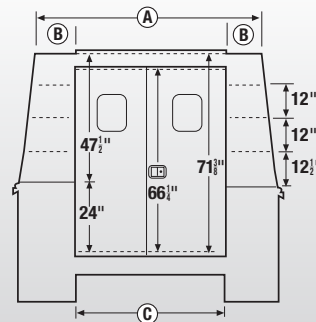

Rear View  
**72 Series (TPA)**

\*Denotes panel top weight only

\*\*Available factory installed only

## Spacemaster Bodies

- Enclosed work area, plus four lift-up doors
  - Upper roadside compartments permit direct access to the interior
  - Upper exterior doors feature pneumatic struts and T-handle locks
- Available in galvanized steel or fuel-saving aluminum
- Protected by acrylic E-Coat priming and powder coat finish



### 108DW Spacemaster Body 57 Series

With recessed tail lights and optional recessed safety step bumper

## SPACEMASTER TOPS

Model	Approx. Wt.*	Cab-to-axle	A	B	F	G	H	I	J	K
	Steel									
SPM57-98DW	761 lbs.	56"	98"	49"	73"	18"	48-1/2"	11"	84-3/4"	12" x 42-3/4"
SPM57-U108SW**	745 lbs.	60"	108"	54"	62-7/8"	13"	48-1/2"	9"	74-5/8"	12" x 48-3/4"
SPM48-U108DW	696 lbs.	60"	108"	54"	72-1/2"	18"	48-1/2"	11"	84-3/4"	7-7/8" x 48-3/4"
SPM57-U108DW	815 lbs.	60"	108"	54"	73"	18"	48-1/2"	11"	84-3/4"	12-1/2" x 48-3/4"
SPM57-UR132DW	978 lbs.	84"	132"	44"	73"	18"	48-1/2"	11"	84-3/4"	11-3/4" x 39"

### 48 SERIES

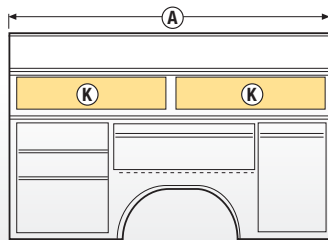
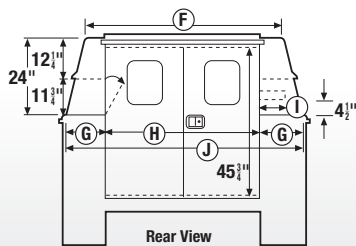

### 57 SERIES

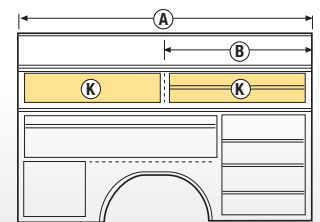
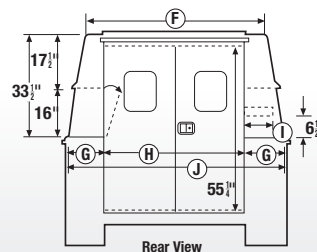

\*Denotes Spacemaster top weight only. \*\*Available factory installed only. NOTE: SPM57-UR132 has (3) "K" compartments each side, equally spaced

### Standard Shelf and Divider Equipment

All models feature 1 shelf and 4 dividers in curbside front compartment only. Shelves are removable and dividers are adjustable and removable

Dimensions and specifications for lower compartment areas correspond to Reading service bodies with equivalent model numbers (minus prefix SPM48 or SPM57) shown above

**DEPENDABLE | DURABLE | RUGGED | VERSATILE**



# READING HAS A FULL LINE OF TRUCK BODIES TO CHOOSE FROM ...



Classic II Service Body – Steel



Classic II Service Body – Aluminum



Classic Service Van - Aluminum



SL Service Body



Panel Body



Ready Van SL – Steel



Cranemaster 3200 Body



Platform Body



Marauder Dump Body



Redi-Dek Body



Landscaper SL Body



Redi-Rack Body



Marauder SL Dump Body



Drop Side Dump Body



Stake Body



Custom Body



— NO BODY BETTER —

All dimensions subject to plus or minus tolerance of 1/4" and all dimensions and specifications are subject to change without notice. Some items displayed in photographs are optional. Aluma-Fill, Aluma-Check, Dual-Pro, Ergo Glide-N-Lock, Latch-Matic, Marauder, Reading, Redi-Dek, Spacemaker, and Tool-Mates are registered trademarks of Reading Truck Group in the United States and some foreign countries. The Reading Kangaroo is a trademarked image and may not be reproduced or used without express permission from Reading Truck Group.

SOLD AND SERVICED LOCALLY BY



MVA MEMBER VERIFICATION PROGRAM